

# **Information Operations: Wisdom Warfare For 2025**



A Research Paper  
Presented To

Air Force *2025*

by

Lt Col Edward F. Murphy  
Maj Gary C. Bender  
Maj Larry J. Schaefer  
Maj Michael M. Shepard  
Maj Charles W. Williamson III

April 1996

## **Disclaimer**

*2025* is a study designed to comply with a directive from the chief of staff of the Air Force to examine the concepts, capabilities, and technologies the United States will require to remain the dominant air and space force in the future. Presented on 17 June 1996, this report was produced in the Department of Defense school environment of academic freedom and in the interest of advancing concepts related to national defense. The views expressed in this report are those of the authors and do not reflect the official policy or position of the United States Air Force, Department of Defense, or the United States government.

This report contains fictional representations of future situations/scenarios. Any similarities to real people or events, other than those specifically cited, are unintentional and are for purposes of illustration only.

This publication has been reviewed by security and policy review authorities, is unclassified, and is cleared for public release.

## *Contents*

<i>Chapter</i>	<i>Page</i>
Disclaimer.....	ii
Illustrations.....	iv
Tables.....	iv
Executive Summary.....	v
1 Introduction.....	1
2 Required Capabilities.....	6
Required Knowledge Capabilities.....	7
Required Wisdom Capabilities.....	9
Required Human System Integration Capabilities.....	10
3 System Description.....	14
Knowledge Systems.....	17
Wisdom Systems.....	20
Human System Integration.....	22
Key Technologies.....	26
Countermeasures and Countercountermeasures.....	29
4 Concept of Operations.....	35
5 Investigation Recommendations.....	39
Knowledge and Wisdom Recommendations.....	40
Human System Integration Recommendations.....	41
Cost.....	42
Schedule.....	46
Appendix	Page
A Acronyms and Abbreviations.....	51
Glossary.....	52
B Operation Swift Split.....	54
Bibliography.....	62

## Illustrations

<i>Figure</i>	<i>Page</i>
1-1. The Role of Information Operations in Aerospace Power .....	2
1-2. The Wisdom Process .....	3
2-1. Course of Action Development .....	10
3-1. Wisdom Warfare Architecture .....	15
3-2. The Knowledge and Wisdom Spheres .....	18
3-3. Genius Ghosting: Sun Tzu, Napoleon, and Clausewitz.....	21
3-4. Common View of the Battlespace .....	26

## Tables

<i>Table</i>	<i>Page</i>
1 Technology Investment Opportunities .....	43

## *Executive Summary*

*A robust information operations architecture can provide leaders dominant battlespace knowledge and tools for improved decision making.* US armed forces in 2025 need an information operations system that generates products and services that are timely, reliable, relevant, and tailored to each user's needs. The products must come from systems that are secure, redundant, survivable, transportable, adaptable, deception resistant, capable of fusing vast amount of data, and capable of forecasting.

The information operations architecture of 2025 this paper proposes consists of thousands of widely distributed nodes performing the full range of collection, data fusion, analysis, and command functions—all linked together through a robust networking system. Data will be collected, organized into usable information, analyzed and assimilated, and displayed in a form that enhances the military decision maker's understanding of the situation. The architecture will also apply modeling, simulation, and forecasting tools to help commanders make sound choices for employing military force. This architecture allows the United States (US) armed forces to conduct Wisdom Warfare.

The system can be used by the commander in chief, unit commander, supervisor, or technician. Somewhere in the workplace, in a vehicle, or on the person there will be a link to the sensors, transmitters, receivers, storage devices, and transformation systems that will provide, in push or pull fashion, all the synthesized information needed to accomplish the mission or task. Information will be presented in a variety of forms selected by the user.

To realize this capability in 2025, America's armed forces will have to alter the way they do business. Doctrinal and organizational changes will have to overcome institutional biases and orchestrate the development of an open architecture. The commercial market's lead in information technology development must be leveraged. New approaches to computing, as well as advancements in processing speeds and capacity, artificial intelligence (AI), software development, and networking must be investigated. In addition, research on human decision-making processes, human system integration, and display technology must be fostered.

To win in 2025, the armed forces of the United States will require an information operations architecture that uses information better and faster than its adversaries. This architecture must be effective across the spectrum of military operations and in any alternate future. To achieve this feasible system by 2025, America must begin to commit its time and money.

# **Chapter 1**

## **Introduction**

In 2025, it is likely the United States will have fewer forces.<sup>1</sup> Most of these forces will be based in the continental US (CONUS). They will be responsible for a variety of missions that will require much greater speed and flexibility than exists today. To meet these requirements, US armed forces of 2025 will have to use information better and faster than their opponents.

“Information operations”, a subset of information warfare, deals exclusively with the use of military information functions. It is how data is gathered, manipulated, and fused. It includes such functions as intelligence, surveillance, reconnaissance, command and control, communications, precision navigation, and weather. Information operations does not include actions to deny, corrupt, or destroy the enemy’s information or efforts to protect ourselves against those actions.<sup>2</sup> Figure 1-1 shows where information operations fits within the realm of information warfare.<sup>3</sup>

# ← INFORMATION WARFARE →

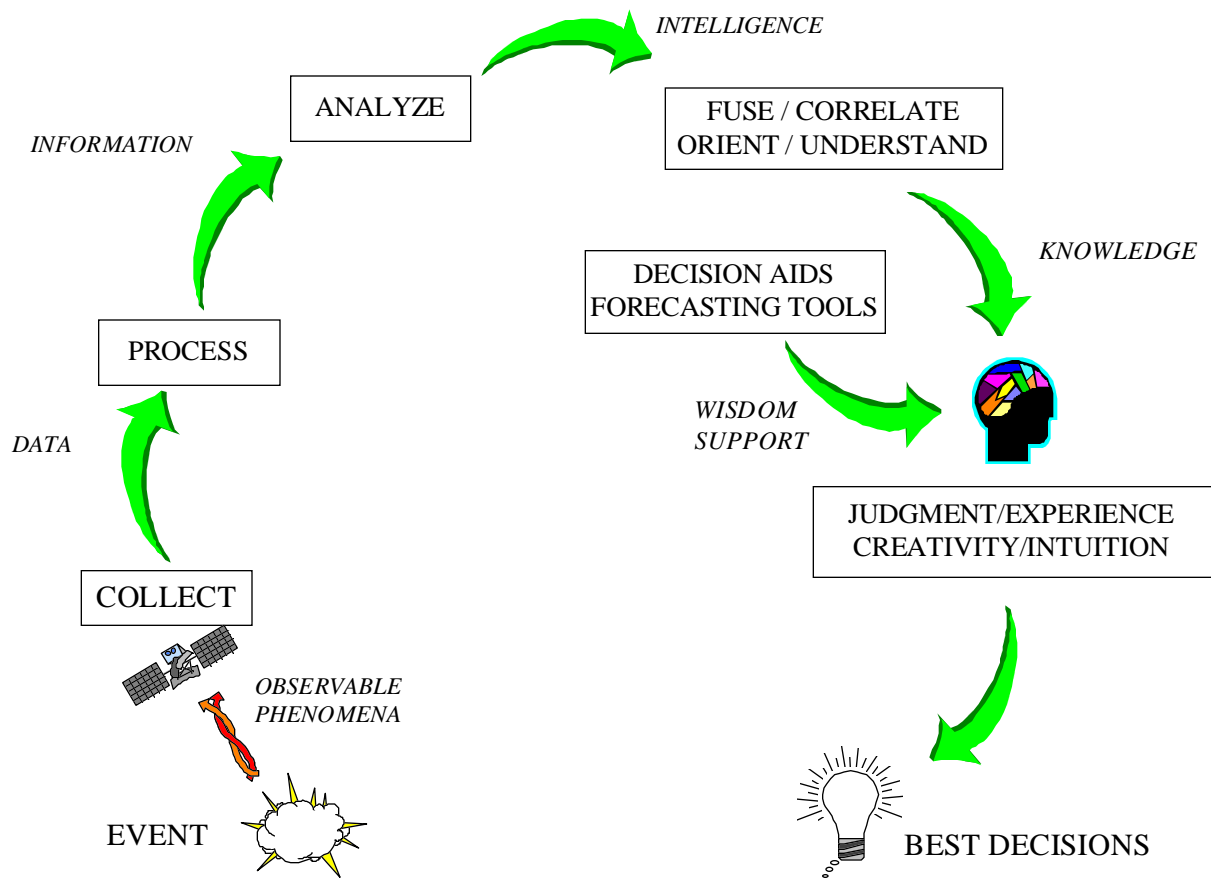
Roles and Missions of Aerospace Power			
<u>Aerospace Control</u>	<u>Force Application</u>	<u>Force Enhancement</u>	<u>Force Support</u>
Counterair	Strategic Attack	Airlift	Base Ops & Def
Counterspace	Interdiction	Air Refueling	Logistics
Counterinformation	Close Air Support	Spacelift	Combat Support
	C <sup>2</sup> Attack	Special Operations	On-Orbit Support
		<i>Information Operations</i>	

**Figure 1-1. The Role of Information Operations in Aerospace Power**

Information operations involve the acquisition, transmission, storage, or transformation of information that enhances the employment of military forces.<sup>4</sup> Information operations devices and systems must be properly applied to give the warrior information superiority. To be useful, the information, a combination of data and instructions, must reduce uncertainty.<sup>5</sup> Acquiring information and putting it in a useful form will help achieve knowledge. “Knowledge and control of information is necessary for all missions, whether in peace or war, logistics or combat.”<sup>6</sup> More is needed to achieve true information superiority. The next step required is wisdom.<sup>7</sup> In this paper, wisdom is defined as knowledge coupled with good judgment.<sup>8</sup> The Wisdom Warfare architecture can dramatically improve a warrior’s good judgment by synthesizing information and modeling and simulating scenarios to provide advice, options, and probabilities of occurrence.



To better understand *wisdom operations*, the process must first be defined. The fundamental principles for acquiring intelligence information against an adversary remain valid over time. Figure 1-2 illustrates the flow from observable event to wisdom. First, some observable event must occur. That event must be observed by a sensor or sensors. The sensors collect the observable phenomena of the event and produce data. The data are processed and forwarded as information. Analysis of the information produces intelligence. The fusion, correlation, and association of relevant archival information lead to an understanding of the event and how it plays a part in the *big picture*. This understanding of the event results in knowledge. Building on that base of knowledge, the decision maker can apply automated decision aids and forecasting



**Figure 1-2. The Wisdom Process**

tools (*wisdom support*) coupled with his own personal judgment, experience, creativity, and intuition to make the best decisions. This is Wisdom Warfare. “It is the association of well-known principles in an innovative way that produces the revolutionary result.”<sup>9</sup> Making the leap from intelligence to wisdom will require innovative approaches for analyzing, fusing, associating, and handling information.

The Wisdom Warfare architecture proposed in this paper has three main components: the *knowledge* component, the *wisdom* component, and the *human system integration* (HSI) component. The *knowledge* component includes systems that collect raw data, organize it into useful information, analyze it to create intelligence, and assimilate it to gain knowledge. The *wisdom* component contains those systems that allow humans to interact with the knowledge to exercise wisdom. This component includes modeling and simulation tools. The final component of the architecture is HSI. The HSI component contains all of the systems necessary to assist decision makers in getting the information needed in the form desired. Once the decision makers understand the information, they can apply experience to make the best decisions.

A properly developed information system will let the warrior observe the battlespace, analyze events, make wiser decisions, and distribute information effectively. What is the aim of such an information system? Sun Tzu said it best. “Know your enemy and know yourself; in a hundred battles you will never be in peril.”<sup>10</sup>

### Notes

<sup>1</sup> Lt Gen Jay W. Kelley, “Brilliant Warrior” (Unpublished paper, March 1996), 4 (prepared for publication in the *Joint Forces Quarterly*, Summer 1996).

<sup>2</sup> Department of the Air Force, *Cornerstones of Information Warfare*, 1995, 3.

<sup>3</sup> *Ibid.*, 11.

<sup>4</sup> Ibid.

<sup>5</sup> Bill Gates, *The Road Ahead* (New York: Viking Penguin, 1995), 30.

<sup>6</sup> USAF Scientific Advisory Board, *New World Vistas: Air and Space Power for the 21<sup>st</sup> Century*, summary volume (Washington, D.C.: USAF Scientific Advisory Board, 15 December 1995), 4.

<sup>7</sup> **2025** Concept, No. 900339, “Understanding Information Hierarchy,” **2025** Concepts Database (Maxwell AFB, Ala.: Air War College/**2025**, 1996).

<sup>8</sup> Philip B. Gove, editor in chief, *Webster’s Third New International Dictionary, Unabridged* (Springfield, Mass.: Merriam-Webster, 1986), 2624, (definition 2 of “wise”: “WISE indicates discernment based not only on factual knowledge but on judgment and insight <wise men . . . anticipate possible difficulties, and decide beforehand what they will do if occasions arise—J. A. Froude>).

<sup>9</sup> *New World Vistas*, summary volume, 13.

<sup>10</sup> Sun Tzu, *The Art of War*, translated by Samuel B. Griffith (London: Oxford University Press, 1971), 84.

## Chapter 2

### Required Capabilities

US armed forces face an array of uncertain futures. They could be called on to perform missions in a variety of environments: deterrence, operations other than war, minor regional conflicts, major regional conflicts, or full-scale war. In addition, those missions will likely be accomplished with a smaller force than today. To accomplish these missions, US armed forces must take advantage of the most significant force multiplier: information.

The proliferation of sensors is creating a flood of information and the flood will likely grow stronger in the future.<sup>1</sup> Tools to handle that flood are insufficient today, and major changes are needed to manage the deluge in 2025.

In the future, information systems must generate products that are timely, current, reliable, relevant, and tailored to the user's needs. These products will come from systems that are secure, redundant, survivable, transportable, adaptable, deception resistant, capable of fusing a vast amount of data, and capable of forecasting.

The challenge in 2025 is to create an adaptive information *architecture* to provide decision makers and operators with superior battlespace awareness by consistently supplying the right information, in sufficient detail, in enough time, to make the best decisions at all levels of command. However, superior battlespace awareness is not enough. The decision makers must

not only be aware of what is happening within their area of interest, they must also understand why it is taking place and what to do about it.

### **Required Knowledge Capabilities**

Achieving superior knowledge over the adversary will require the right mix of multispectral sensors, advanced automated processors, analysis and correlation tools, and dynamic storage devices. These devices must be logically integrated to orient enormous quantities of information in a manner that will impart knowledge to a variety of decision makers.

Sensors must detect a wide variety of phenomena and be deployable around the globe. To achieve this, the conventional intelligence, surveillance, and reconnaissance methods must be complemented with exotic types of information collectors. These techniques might include seismic, acoustic, magnetic resonance imaging, and atmospheric (aircraft and missile wake) detection.<sup>2</sup> The ability to obtain information directly from an adversary's databases (mapping and penetrating the military and commercial information systems of the enemy) remains a high priority. Also included in this mix of data collectors are weather sensors to provide timely and accurate environmental reports. Finally, a new family of low cost, "leave-behind" sensors must be developed to provide near-real-time poststrike effects assessments.<sup>3</sup>

Needs of the emerging weapon systems will drive specific sensor requirements such as resolution or geolocational accuracy. Precision weapons require precision intelligence. Lasers and other directed energy weapons may require resolutions down to a few centimeters.

The Air Force Scientific Advisory Board recently published *New World Vistas: Air and Space Power for the 21st Century*. In it they stated "the power of the new information systems will lie in their ability to correlate data automatically and rapidly from many sources to form a

complete picture of the operational area, whether it be a battlefield or the site of a mobility operation.”<sup>4</sup> This represents the heart of any information operations engine. The ability to fuse vast amounts of data from the multitude of sensors, automatically sort it, identify the essential pieces of information, and provide the right information to the right node in near real time is the goal. This represents one of the greatest challenges. The best system will be able to identify the relevant databases across dissimilar networks, search through and filter vast amounts of stored information, and rapidly analyze and correlate data across distributed databases with thousands or millions of variables.<sup>5</sup> The architecture must automatically maintain current information on designated target sets at all times and assist in targeting by presenting vulnerability, aim points, and strike options. This process must remain effective even when incomplete or uncertain data are part of the underlying situation.<sup>6</sup>

The system must also integrate knowledge of the operating environment, especially the terrain over which forces will operate. A world map using a common grid is needed, plus the ability to provide maps expressed in unique coordinates but derived from a common database or grid.<sup>7</sup> The goal of precision mapping is to provide the user with less than one meter accuracy. An onboard map coupled with navigation aids will permit aircraft and unmanned air vehicles to fly anytime, anywhere, on any route.<sup>8</sup>

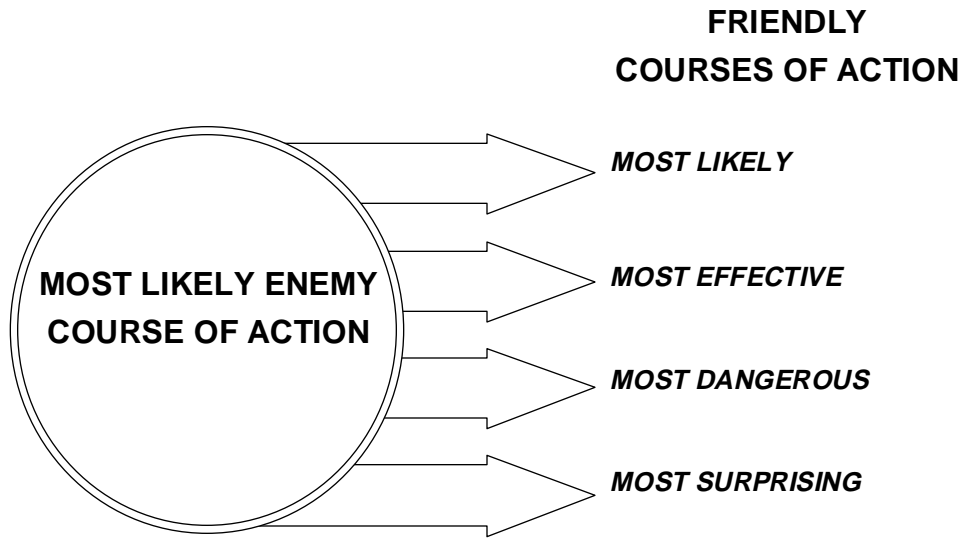
Well-trained personnel are crucial for the proper analysis and evaluation of information; without them the commander is presented with a “regurgitation of previously reported ‘facts’ that may or may not be relevant.”<sup>9</sup> In 2025, the human element is still the key. However, in the face of the information explosion and high tempo military operations expected in 2025, the analytic tasks performed by those well-trained professionals must be complemented by automated processes wherever possible.

The evolving doctrine in the new information age mandates each commander be empowered to act quickly and decisively to changes taking place on the battlefield. For this empowerment to be successful, the information operations architecture must deliver the essential information relevant to that particular commander. The architecture must do this simultaneously for each command or weapon system node.<sup>10</sup> Once the required knowledge is gained, decision makers will need to use it to increase military effectiveness. In other words, they must use the knowledge wisely.

### **Required Wisdom Capabilities**

The *wisdom* component helps decision makers reach good conclusions quickly. The architecture includes the models, simulations, forecasting aids, decision aids, planning and execution tools, and archival methods that enable information superiority over an adversary.<sup>11</sup> The models and simulations also need to incorporate response mechanisms so outcomes are included in future scenarios.

Campaign planning is a critical role for the *wisdom* component. Forecasting tools or intuitive knowledge and decision support systems are critical to the war fighter.<sup>12</sup> In campaign planning, the system can assist the commander by forecasting possible enemy courses of action (COA). Similarly, the campaign planner would pursue various alternatives for friendly COAs. Each of these friendly COAs could be pursued against each of the enemy COAs. Figure 2-1 illustrates this process for the most likely enemy COAs. An ability to permanently store or archive past forecasts and actual outcomes or decisions is required so they are available as input in new scenarios. Linking simulations to real-world exercises on live ranges verifies whether these simulations represent reality.



**Figure 2-1. Course of Action Development**

The *wisdom* component must aid training by allowing friendly forces to perform virtual missions.<sup>13</sup> It must support the modernization of existing systems and development of new systems. This will improve test and evaluation, reduce acquisition cycle times, and reduce costs.<sup>14</sup> It must also model future foreign systems, technologies, and scenarios so the military acquisition system can maintain technical superiority.

### **Required Human System Integration Capabilities**

The human will remain the essential element of the information operation systems of the future. Humans will exercise command and control and apply their unique attributes to information processing and decision making—an integral part of the Wisdom Warfare concept. Humans can process large amounts of information through the five senses; chiefly visual (billions



of bits per second) and audient (tens of thousands of bits per second).<sup>15</sup> However, the human as an information channel (usually transmitting information orally) is limited to about 50 bits per second.<sup>16</sup> Gaining and maintaining information superiority in 2025 will require effective integration and interfacing between humans and systems. This effective integration will rely on improved capabilities in three areas: the human, the system, and the way they interact.

The human area consists of improving and enhancing the way people deal with information. This includes human sensing capabilities and human cognitive functions like problem solving and decision making. The system area consists of developing and improving information transformation systems to include artificial intelligence (AI), intelligent software, information filters, and information access systems. The final area consists of improving and enhancing the integration between humans and systems. This integration focuses not only on improving the human-machine interfaces but also includes the larger idea of gaining synergy between humans and systems. This synergy incorporates capabilities like brain activated control of machines.

Obviously, in an environment of exponential growth in information available to humans, capabilities to improve and enhance the ways humans deal with information are required. The first step is to gain a better understanding of how humans work with information. This requires a significant improvement in the understanding of the immensely complex human brain.<sup>17</sup> The capability to understand how the human brain works in different situations will help improve human performance. A required capability for improvement is enhancement of memory since it has been shown excellent memory helps develop proficiency in situational awareness.<sup>18</sup>

Achieving effective integration between humans and systems will require a long-term systems engineering process. The process will begin early in a person's career where evolved portable computers will be used to store information on the methods the decision maker uses in

problem solving in all kinds of situations. This process will also require training to improve the human mental dexterity in using the system.<sup>19</sup> The human brain is a great processor, and it should be used to the maximum extent possible.

Another required capability is to design systems that can determine the status of the decision maker's cognitive processes and adjust the information available and the way it is being presented to avoid information overload. Improved information displays will be required to present information to the decision maker in a variety of forms.<sup>20</sup> Systems that take into account the nonverbal methods of communication like gesturing and facial expressions need to be developed.<sup>21</sup> As systems become more intelligent and autonomous, humans must understand what actions are being taken and the potential limitations these actions might create for the decision maker.

So what is really required in 2025? First, the leaders of tomorrow must have an architecture that acquires and transforms a vast amount of information from a wide variety of sources. Second, the architecture must forecast courses of action and provide advice to the war fighter. Finally, the architecture must present information in a form that is timely, reliable, relevant, and tailored to the war fighter's information needs.

## Notes

<sup>1</sup> Barry R. Schneider and Lawrence E. Grinter, eds., "Overview: Information Warfare Issues," *Battlefield of the Future: 21st Century Warfare Issues*, Air War College Studies in National Security No. 3 (Maxwell AFB, Ala.: Air University Press, September 1995), 150–151, 189.

<sup>2</sup> *Spacecast 2020*, Surveillance and Reconnaissance Volume (Maxwell AFB, Ala.: Air University, 1994), 3.

<sup>3</sup> **2025** Concept, No. 900518, "Electronic Grid—Throwaway Sensors," **2025** Concepts Database (Maxwell AFB, Ala.: Air War College/**2025**, 1996).

<sup>4</sup> USAF Scientific Advisory Board, *New World Vistas: Air and Space Power for the 21<sup>st</sup> Century*, summary volume (Washington, D.C.: USAF Scientific Advisory Board, 15 December 1995), 11.

<sup>5</sup> *Ibid.*, 24.

<sup>6</sup> *New World Vistas*, (unpublished draft, the technology application volume), 10.

<sup>7</sup> *Ibid.*, 19.

<sup>8</sup> *Ibid.*, 20.

<sup>9</sup> Lt Col Norman B. Hutcherson, *Command and Control Warfare* (Maxwell AFB, Ala.: Air University Press, 1994), 29.

<sup>10</sup> *New World Vistas*, (unpublished draft, the technology application volume), 24.

<sup>11</sup> **2025** Concept, No. 900386, “Computer-Assisted Battle Decision System,” **2025** Concepts Database (Maxwell AFB, Ala.: Air War College/**2025**, 1996).

<sup>12</sup> Department of the Air Force, *Air Force Executive Guidance*, December 1995, 20.

<sup>13</sup> Kelley, “Brilliant Warrior” 9.

<sup>14</sup> *Air Force Executive Guidance*, 21.

<sup>15</sup> Sarnoff Research Center, “Exploiting the Consumer Digital Systems (CDS) Revolution,” briefing to Lieutenant General Kelley, Air University commander, Maxwell AFB, Ala., 24 March 1994.

<sup>16</sup> J. R. Pierce and J. E. Karlin, “Reading Rates and the Information Rate of a Human Channel” (Convention Record Part 2, IEEE WESCON, 1957), 60.

<sup>17</sup> *Compton’s Interactive Encyclopedia*, 1994 ed., s.v. “human brain.” Given that the human brain contains 100–200 billion neurons with each one connected to 1,000 or more other neurons and having more than 60 chemical messengers (neurotransmitters and neuropeptides) to communicate with in any combination, “the number of possible brain states is inconceivably large.”

<sup>18</sup> *New World Vistas*, (unpublished draft, the human systems and biotechnology volume), appendix M, 2-4.

<sup>19</sup> Additional required capabilities can be found in 2025 white papers on General Education and Training; Training and Readiness; and Information Technology in Education and Training.

<sup>20</sup> *New World Vistas*, (unpublished draft, the human systems and biotechnology volume), appendix F. Appendix F describes research for improving the design of displays. Though the discussion focuses on improvements for displaying information to pilots of aircraft these concepts can be used in a large variety of situations.

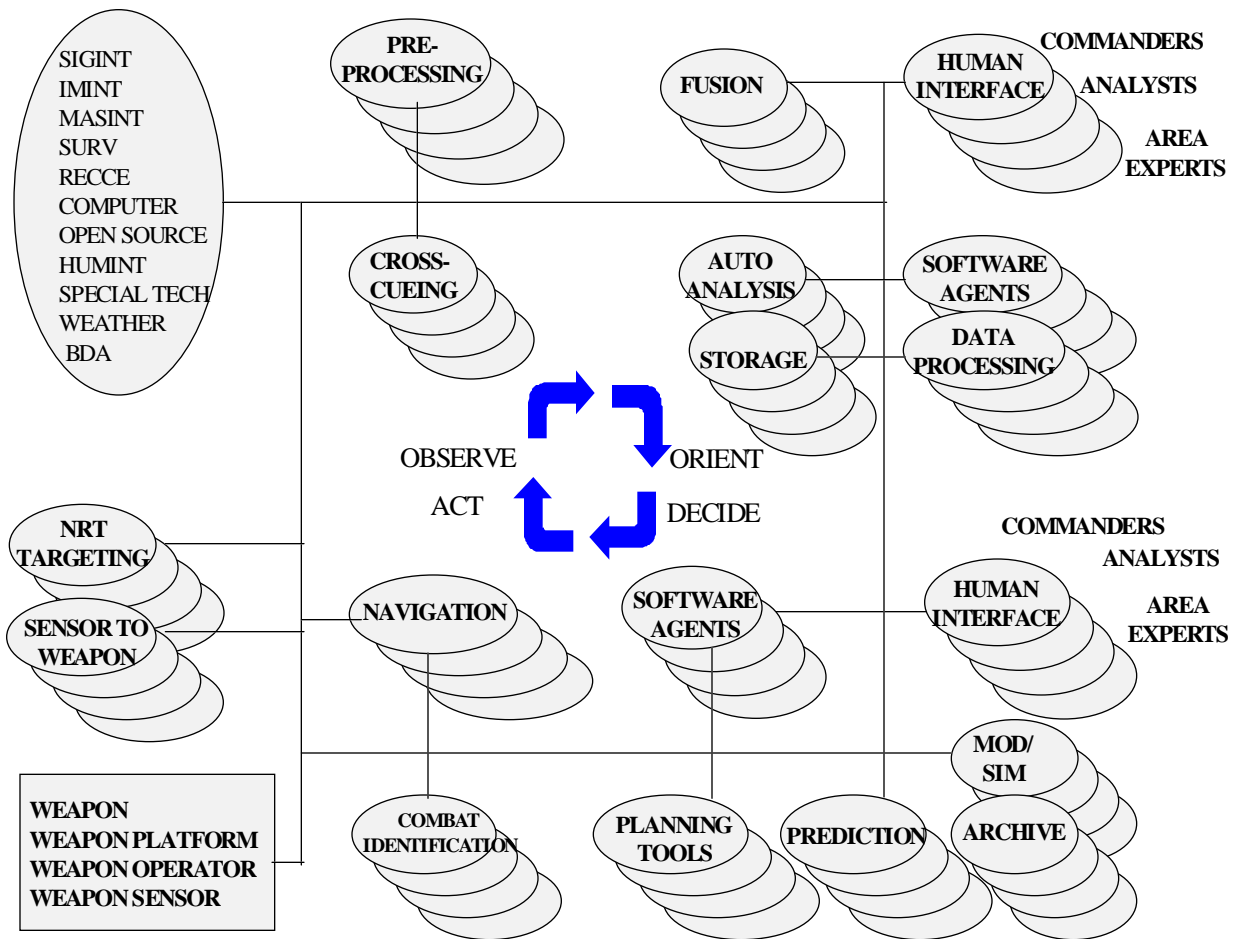
<sup>21</sup> Nicholas Negroponte, *Being Digital* (New York: Vintage Books, 1996), 91–92; Idem, “Affective Computing,” *Wired*, April 1996, 184.

## **Chapter 3**

### **System Description**

This section describes an architecture of information systems for use by the US armed forces in 2025. All the capabilities may not be possible by 2025. However, this paper was written to provide the map to near-maximum expected capability. Any stop short of that destination will still have useful features for air power.

The information operations architecture of 2025 consists of thousands of widely distributed nodes, performing the full range of collection, data fusion, analysis, and command functions, all linked through a robust networking system. It is an open architecture allowing modular upgrades without massive redesign. The architecture collects raw data, organizes it into useable information, analyzes and assimilates it, and imparts it in a form that enhances the military decision-maker's understanding of the battlespace. The architecture also applies modeling, simulation, and forecasting tools to help commanders make sound choices for employing military force.



**Figure 3-1. Wisdom Warfare Architecture**

Figure 3-1 shows one vision of this architecture. (Abbreviations are listed in appendix A.) It is a functional rather than a physical depiction. To understand how this architecture operates, it is helpful to divide it into four functional areas that mirror the Col John R. Boyd OODA loop; that is, *observe*, *orient*, *decide*, and *act*. This division is for illustrative purposes only. In reality, when dealing with information operations, it is difficult to determine exactly where one function ends and another begins. All the nodes are tied together; they exchange information, share processing and storage capacity, and all work together to solve a common problem—superior battlespace knowledge and wisdom. All four elements of the OODA loop are represented in the

architecture and are vital to its proper functioning. However, the focus of this paper is on *orient* and *decide*, which can be roughly equated to the *knowledge* and *wisdom* components. The *observe* and *act* functions are the subjects of other white papers and will be addressed here only briefly.

Within the *observe* component of the architecture, most data collection occurs. Included are all the traditional elements of sensing commonly found in intelligence, surveillance, and reconnaissance. Also included are sensors for weather and terrain mapping, as well as new collection techniques such as noninvasive magnetic source imaging, magnetic resonance imaging, and aircraft wake turbulence detection.<sup>1</sup> Sensors process data as far forward as possible, at the point of collection in some cases, to reduce overall observation reporting time. New chip architecture offers the promise of lighter and more efficient hardware, improved power requirements, and reduced failure potential for a host of sensor equipped devices.<sup>2</sup>

Many weapon systems, especially airborne weapon systems, are capable of contributing their observations to the overall architecture, as well as being capable of autonomous operations with their sensor suites to reduce their reliance on any vulnerabilities in C<sup>2</sup> systems.

For Battle Effects Assessment, expendable sensors can deploy with the weapon systems.<sup>3</sup> These sensors could consist of miniature gliding flight vehicles that carry onboard processors, independent navigation capabilities, and various sensing technologies including optical, infrared, radio frequency, and acoustic.

The *observe* component also includes nodes for the correlation and fusion of sensor data from different sources and nodes for sensor cross-cueing to provide automated sensor-to-sensor tip-offs for collection steering. Additionally, there are nodes for collection management of

preplanned and directed search activities. Finally, the *observe* functional area is tightly linked, accessible, and highly responsive to the *act* component.

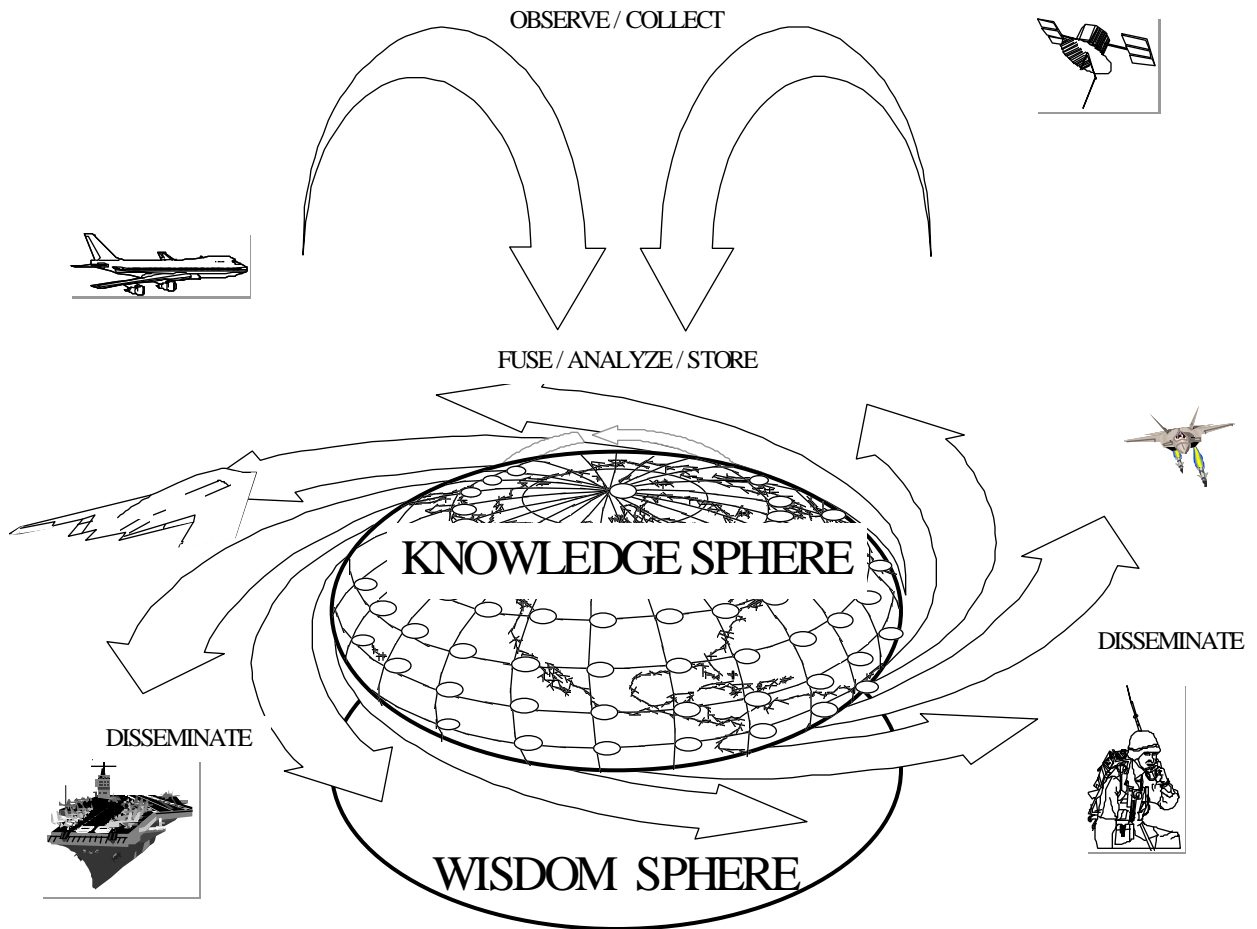
The elements within the *act* area include those directly supporting a weapon system in accomplishing its task. Of course, the *act* component in 2025 may well include air power actions other than “bombs on target.” The system must provide navigation, combat identification, and targeting information. Weapon systems have direct links to the *observe* component. This direct link provides real-time (seconds) sensor-to-shooter and sensor-to-weapon data flow and provides near-real-time (minutes) targeting information to planning cells. These links must be developed in conjunction with the development of the weapon system to ensure full integration rather than an add-on capability. Since specific weapon systems design of 2025 is beyond the scope of this paper, this area of information operations will not be addressed further.<sup>4</sup>

### **Knowledge Systems**

The *orient* component of the architecture performs what this paper describes as the *knowledge* function of information operations. It contains the various nodes for automated data fusion, analysis, storage, and retrieval. It is composed of a mix of old and new technologies in an open architecture that allows incremental upgrades of individual elements as technology continues to advance. The architecture is also networked in a fashion that allows graceful degradation as a result of enemy action or component failure (fig. 5).

As a result of many years of collecting information from a wide variety of sources and methods, the architecture’s databases contain information on virtually every potential target set or system vulnerable to combat power, both lethal and nonlethal. This information includes an up-to-date compendium of physical descriptions, multiple view images, floor plans, material lists,

subsystem component descriptions, technical specifications and drawings, operations manuals, and relationships with other systems.<sup>5</sup>



**Figure 3-2. The Knowledge and Wisdom Spheres**

This massive amount of information is too large for humans to maintain and keep current without the help of automation. The architecture automatically recognizes gaps, deficiencies, or outdated information in the databases and, without human intervention, searches the global information net.<sup>6</sup> It then retrieves the information directly from the various information libraries around the world, or sends a request for collection of the missing or outdated information. The architecture tracks the progress of the response and follows up as necessary. The architecture



also reviews numerous satellite images and alerts human analysts of any changes found at potential target areas making obvious exceptions for weather.

Besides information on potential adversaries, the architecture also integrates information on our own and allied forces as reported from the *act* component. This friendly information includes maintenance status, crew health and availability, location, and mission status.<sup>7</sup>

New generations of nonmagnetic media—possibly associated with lasers, optical disks, and other newly emerging technologies—will be used to store data. Client-server and distributed data warehouse models can transfer data from the source to the military users' local storage media.<sup>8</sup> The architecture can take advantage of lower-cost technologies as well. If massive communications bandwidths are relatively inexpensive, then users' storage devices do not have to be unlimited since the users have unlimited access to source servers. The users simply download what is required for a given mission. However, if cost favors large local memory, then the system could use it and only rely on communications for updates.

Algorithms specifically designed for synchronization, truth maintenance, and queuing delays are used to efficiently integrate all this data from very large distributed databases.<sup>9</sup> Every individual data set is tagged with a location indicator to permit immediate and automatic synchronization and alignment of the data or objects of interest.<sup>10</sup>

Data fusion is crucial to taking the massive amount of data available and turning it into useful information without overloading either the human or the information systems themselves. The fusion process takes place across the entire distributed network of sensors, computing servers, and platforms. The architecture integrates fusion applications across multiple nodes using coordination languages to tie together dissimilar operating systems. To do this it employs many separate tools (target models, search, and filtering algorithms) with very large amounts of

common sense knowledge. Key fusion functions include automatic target recognition, multi-target tracking, pattern recognition, and object relationship analysis for dynamic situation assessment.<sup>11</sup>

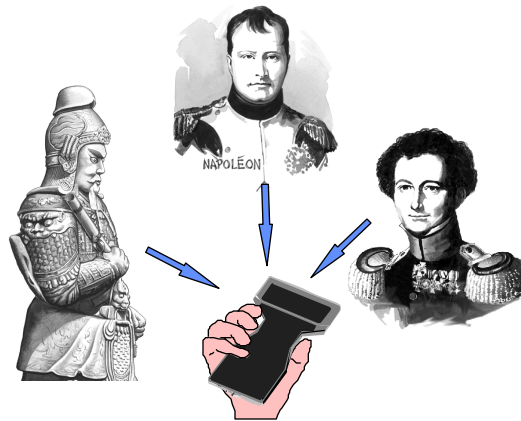
Achieving *knowledge*-level and *wisdom*-level fusion requires information access technology (IAT) for searching across very large distributed databases.<sup>12</sup> One promising approach for IAT is the use of artificial intelligence or intelligent software agents (ISA). ISA are discussed in greater detail in the Key Technologies section.

The next portion of the information architecture is the *decide*, or *wisdom*, component. With much of the correlation, fusion, and basic-level analysis accomplished by automation, the human will spend less time on where the tanks are and more time on which tanks would be the most effective to attack.<sup>13</sup> This is where modeling, simulation, and decision tools come into play.

### **Wisdom Systems**

The *wisdom* component includes the modeling, simulations, software agents, forecasting tools, decision aids, planning and execution tools, and the archival methods that enable US armed forces' information and knowledge to be superior over an adversary. Usually, the commander who has explored the most alternatives before combat emerges victorious. The forecasting tools will present a range of possible enemy COAs based on the current situation as defined by the knowledge process and based on historic precedence as recalled from the archives. The *wisdom* systems also identify potential strengths and weaknesses for each forecasted enemy COA. The campaign planner may try out, through modeling and simulation, various friendly responses to each of the enemy COAs. The system identifies probabilities of success and identifies potential weaknesses in friendly COAs.

A powerful new tool in the *wisdom* component is genius ghosting (fig. 6). Genius ghosting uses the concepts of historic figures, factors in the current context, provides COAs, then simulates the results to provide probabilities of various outcomes. Academic institutions could provide the historical framework. The *knowledge* component provides the current context. Models provide the COAs. Simulations provide the probabilities of outcomes.<sup>14</sup> For instance, the Wisdom Warfare system could apply a principle of Sun Tzu: “The doctrine of war is to follow the enemy situation in order to decide on battle. Therefore at first be shy as a maiden. When the enemy gives you an opening be swift as a hare and he will be unable to withstand you.”<sup>15</sup>



**Figure 3-3. Genius Ghosting: Sun Tzu, Napoleon, and Clausewitz**

The COAs would include a reactive strike rather than a preemptive strike. They would include forces in defensive positions until the time is right to strike. The Wisdom Warfare system then “wargames” those COAs to provide probabilities of outcomes. By comparing the COAs provided by many different “genius ghosts,” a commander will have a broader range to choose from. For instance, a commander could ask how Doolittle, Kenney, or Horner might design a particular campaign, then pick the elements that work best. In addition, the commander can

avoid the dangers of dogma by selecting an unexpected COA, for instance, Doolittle's raid on Tokyo. The goal of genius ghosting is not to rigorously predict how a particular figure would fight a campaign. Instead, it is to give the commander a wider variety of creative options than he would have without Wisdom Warfare.

The Wisdom Warfare system also has a feedback mechanism allowing for course corrections (continuous updates and suggested corrections) based on pitfall predictors (after analyzing decisions and potential outcomes) and way point and metric analysis (indications of what to look for). The system learns from actual outcomes and advises the warrior.

The distinctive advantage of the 2025 *wisdom* system is that it is nearly autonomous and produces output just as fast as information is added or subtracted. It can be used during modeling, simulation, acquisition, planning, conflict execution, and conflict termination. In addition, this system applies not just to the strategic and operational levels of military operations but to the tactical as well.

A note of caution is appropriate at this point. There are two areas that may cause concern. First, the architecture design needs to recognize that each decision maker has bias in dealing with information. Second, as the architecture becomes human-like, there may be a tendency for the decision makers to become over-reliant on the architecture. This architecture realizes these two concerns and addresses them through the *human system integration* (HSI) component.

### **Human System Integration**

To make the cycle complete, the system and the decision maker must interact to do something useful with that knowledge and wisdom. Given the proliferation of data and the

exponentially expanding capabilities to gather data, a major challenge is to extract only the required data and transform it into a useable format for each specific decision maker when and where it is needed. Links for the information operations architecture maximize the use of the national information infrastructure, both government and commercial.

Using ISAs, the network automatically forwards to each node the essential knowledge that is most relevant for that particular node at any given moment. This requires each node to identify the most essential pieces of knowledge by type, level of detail, and timeliness for it to accomplish its mission. Over time, ISAs help users by learning information desired in a given situation. Each node, of course, retains the ability to pull additional information from the system or each information pushed from a superior node to a subordinate node as required.

The objective of HSI is to make it easier, faster, and more efficient for decision makers to adapt to the environment quickly, gain situational awareness, and apply their wisdom to make the best decisions possible. The architecture incorporates the continued advances in areas like time-critical decision making,<sup>16</sup> reducing information overload,<sup>17</sup> and human computer interaction.<sup>18</sup>

To allow quick adaptation to the environment, the human sensory and cognitive capabilities will be improved through a combination of technologies and training. The human senses can be enhanced through technology aids and drugs. “Smart” eyeglasses or contact lenses can present more than just the visible portion of the electromagnetic spectrum. Hearing aids can translate a wider range of sounds. Other aids will improve smell or incorporate scents into various tasks like memory recall or heightened sensitivity to help focus decision makers on the task at hand.<sup>19</sup> The technology aids also augment other senses to allow recognition of emotions to aid in other decision-making environments such as negotiations. Training is provided to teach the decision

makers how to use these enhanced sensory powers. This leads to focusing human cognitive functions so they can make the best use of this information.

With a good understanding of how the human brain works, integration of the human and the system is achieved. It consists of improving the presentation of information to the decision maker given a preference for displays, problem-solving methods, current state of mind, and the situation at hand. The majority of this information will be stored in a personal digital assistant (PDA). The PDA can include training, exercises, and real event data.

Additional tools enhance the human's ability to be trained.<sup>20</sup> The goal is to provide a robust training system that takes advantage of the enhancing technologies described above. Through modeling and simulations, decision makers will be presented with the experiences they need to develop the lessons learned that lead to wisdom. These techniques can be used to speed up the training process—similar to accelerated life-cycle testing of hardware.

Displays are adaptive and flexible to account for each individual's preferences. They provide information through all the senses and include text, graphic, virtual, and holographic methods. They are tailored to optimize each user's learning and absorption capabilities. Additional technologies will be developed to allow human interaction with the displays. These technologies allow the displays to work with the human to adjust to each situation. The displays are scalar to allow zooming to the desired level of detail.<sup>21</sup> In this way the commander in chief can see the big picture of the battlespace or zoom to see the situation at the local level.

As mentioned above, the PDA learns the profiles of the items the decision maker believes are important and creates information filters to assist in avoiding information overload. The displays, in conjunction with modeling and simulations, also provide the capability of presenting the *ghosting* of geniuses as desired. In addition, the display is flexible enough to allow several

people to view at the same time and through connections make collective inputs to aid the decision maker. This could be done at the same location or remotely using video teleconferencing for a common view of the battlespace.

Displaying a common picture of the battlespace is critical in ensuring the decision maker's intent is clearly communicated to all levels. Three-dimensional holographic displays are useful, particularly for users working in groups. Another example is "smart" glasses or contact lenses enabling the new concept of "eyes-up display."<sup>22</sup> The systems are completely interoperable and are able to tie into the network wherever users are located. The architecture takes advantage of secure, reliable, high capacity communications systems advanced by the commercial world. Through the combined use of these systems the decision makers are able to communicate their intent to all necessary levels and the advantage of having a common view of the battlespace is realized. Figure 3-4 is an example of this common picture of the battlespace.



**Figure 3-4. Common View of the Battlespace**

### **Key Technologies**

This section describes some of the key technologies that apply across the entire architecture, including computational power and software.

The computational power contained in this architecture comes from a mix of old (traditional parallel processors, digital signal processors) and new models. One promising new computational approach is based on deoxyribonucleic acid (DNA) molecules. Computer designs based on DNA promise an extraordinary processing capability that operate at billions of tera-operations per second.<sup>23</sup> While the operations per second rate is very high, it can take hours to complete an



entire DNA reaction. Therefore, DNA computing is best suited for complex problems with many variables, such as long-term surveillance and planning, which do not require response times that are measured in seconds.<sup>24</sup> In addition, pipelined, superscalar, and parallel processors show promise for computing power near six billion operations per second.<sup>25</sup>

The use of ISAs is vital to the proper functioning of both the *knowledge* and *wisdom* components. These agents are software modules that act independently and have a range of capabilities including directed-action, reasoned-action, and learned-action.<sup>26</sup> Directed-action agents have fixed goals and limited ability to deal with the environment and data encountered. Reasoned-action agents have fixed goals and an ability to sense both environment and data and take a reasoned action. Learned-action agents can do all the above. Additionally, they can accept high-level tasking and are capable of anticipating user needs based on general guidelines. Armed with this information, learned-action agents can issue new goals.

Intelligent software agents demonstrate reasoning and persistence in performing tasks. These *agents* work with their users to determine information needs, navigate the information world to locate appropriate data sources—and appropriate people—from which to extract relevant information. They also act as intelligent, long-term team members by helping to preserve knowledge about tasks, record the reasons for decisions, and retrieve information relevant to new problems.<sup>27</sup>

Neural network software provides another capability. Programmers give the system training data with known conclusions. The system then takes a great amount of information and draws a conclusion.<sup>28</sup> In a future where vast amounts of data are expected, systems that feed on data will be valuable.

Hardware and software must be coupled with advanced automated logic methods. For instance, the statistics of Markov chains can be used to predict the highest probability outcome of COAs.<sup>29</sup> Markov chains could be used to evaluate enemy and friendly COAs.

Another modeling tool is the fuzzy cognitive map (FCM).<sup>30</sup> The FCM draws a causal picture to predict how complex events interact and play. It can even handle imprecise rules like: “Bombing an electrical generator *usually* decreases generator output.” The FCM relies heavily on feedback that allows it to be dynamic until it reaches an equilibrium point where a hidden pattern will emerge. This allows predictions of nonlinear system operations, including social systems. FCMs would also be useful in evaluating enemy and friendly COAs.

Chaos theory, a branch of mathematics, provides another modeling tool. Chaos theory deals with the behavior of bounded, nonlinear systems that are sensitive to small perturbations. Chaotic systems often appear to behave randomly but operate within defined bounds. There is reason to believe chaotic behavior occurs in human and organizational decision making and in combat operations.<sup>31</sup> Several features of chaos theory should prove useful. First, techniques like “embedding” make short-term forecasting possible and “attractors” describe the boundaries of the long-term behavior of chaotic systems.<sup>32</sup> These would be useful for forecasting enemy COAs, and the outcome of enemy and friendly COAs. Unlike Markov chains and FCMs, chaos attractors can describe the bounds of a number of outcomes rather than just the most likely one. Second, “Lyapunov exponents” help quantify sensitivities to small disturbances. These would be useful in determining what COAs may result in the greatest gains for the smallest additional inputs of military power. Third, calculations of the “information dimension” indicate the minimum number of variables needed to model a system.<sup>33</sup> The information dimension may indicate that a few variables drive a seemingly random system. Additionally, it makes modeling

the system from actual data easier and faster. Overall, chaos theory holds great promise in a wide variety of areas.

Human system integration relies on an integrated use of technologies like: electroencephalograph (EEG),<sup>34</sup> ISAs, information displays, and training programs. EEGs will determine the mental state of the decision maker and tailor displays as appropriate. They will also assist the decision maker in performing computer-related tasks by brain activated control.

### **Countermeasures and Countercountermeasures**

The force-multiplying effect of the Wisdom Warfare architecture on the effective employment of US forces presents a potential center of gravity no adversary can ignore. The attack methods expected to be directed against the architecture include the full range of countermeasures designed to disrupt, degrade, deny, and/or destroy, either locally or globally, the information functions provided to US forces.

In an attempt to disrupt the flow of information to decision makers, physical attacks against key nodes using conventional high explosives or electronic signal jamming are expected. These traditional methods of attack are easily countered through hardening (both the electronics and the physical facilities), dispersal, and redundancy. Indeed, the very nature of the architecture, with its multiple nodes and distributed processing, eliminates any “critical node” target or possibility of a single point of failure. Even if individual nodes or decision makers are effectively cut off from the architecture due to enemy action, the immediate effect is felt only at those isolated points and not across the entire architecture. The information flow is automatically rerouted around the disrupted node, allowing a seamless, continual flow of information.

The distributed nature of the architecture coupled with multiple forecasting models also aids its resistance to deception. The numerous observation nodes using a wide variety of sensing phenomenology, correlation tools, and historic databases greatly reduce the probability a battlefield deception effort by an enemy will be successful. By using multiple forecasting models, the Wisdom Warfare architecture is self-defending since the enemy would have to deceive multiple systems simultaneously.

The most dangerous forms of attack are those designed to corrupt, distort, or implant false information into the databases. These types of attacks may occur without any indications the system is under attack. Included in this form of attack are malicious software, computer viruses, chipping (manufacture of computer chips with malicious design flaws), spoofing, video morphing, and surreptitiously gaining local control of the flow of information on the network.<sup>35</sup> Advances in intelligent software, cryptography, and user-recognition techniques offer some degree of protection against these attacks.

The interface software at each node can provide the first level of protection by ensuring the data message that is attempting to gain access to that node is from whom it purports to be. Using message authentication, each node will verify the data message's origin and whether the data has been altered.<sup>36</sup>

Intelligent software agents can also be employed to monitor the network for the presence of malicious software and computer viruses. The agents can then attack and eliminate the viruses, or isolate them from the rest of the architecture to prevent their spreading, and notify the human operator for further corrective action.

Preventing computer viruses or malicious software from entering the architecture is a high priority. Cryptographic technology provides very high levels of security against unauthorized,

surreptitious access to the information network. Encryption techniques can develop keys that may take eons to break (even using the computational power available in 2025), ensuring secure data at individual nodes and throughout the net.<sup>37</sup>

Unauthorized access can also be partially controlled by breakthroughs in biometric identification technologies. These technologies use physiological traits such as voice, fingerprint, eye, or face recognition to provide a continuous identity check of all operators who are using the system's HSI devices to retrieve information from, or input information into, the architecture. If these techniques fail, the system can disconnect any node believed to be compromised or captured.

Finally, unbreakable codes and biometric identification technologies offer no protection against the threat of compromised personnel. Renewed efforts are required to ensure national security policies monitor those individuals who are authorized access to the network and identify potential lapses in architecture integrity. Because technology is constantly evolving, countermeasures and concomitant countercountermeasures will similarly be changing. The operators and maintainers of the *wisdom* architecture must remain vigilant and continue to make changes to the security structure to stay ahead of advances and changes by an adversary.

In 2025, the system described in this chapter can be used by anyone: the commander in chief, unit commander, supervisor, or technician. Somewhere in the workplace, in a vehicle, or on the person will be a link to the sensors, transmitters, receivers, storage devices, and transformation systems that will provide, in push or pull fashion, all the synthesized information needed to accomplish the mission or task. Information will be presented in a variety of forms selected by the user. Key technologies like advanced processing, intelligent software agents, neural network software, automated logic methods, improved modeling techniques, and improved

human system integration will make this system a reality. Certainly, there are countermeasures to such a system and one of the challenges in 2025 will be to protect the architecture both with physical and software security measures.

## Notes

<sup>1</sup> *SPACECAST 2020*, Surveillance and Reconnaissance Volume (Maxwell AFB, Ala.: Air University, 1994), 3.

<sup>2</sup> “Chip Architecture Removes Signal Processing Bottleneck,” *Signal*, February 1996, 58.

<sup>3</sup> **2025** Concept, No. 900404, “Built-in Battle Damage Assessment,” **2025** Concepts Database (Maxwell AFB, Ala.: Air War College/**2025**, 1996); **2025** Concept, No. 900578, “Bulls Eye,” **2025** Concepts Database (Maxwell AFB, Ala.: Air War College/**2025**, 1996); Department of the Army, *Force XXI*, 15 January 1995, 15–17.

<sup>4</sup> For additional information see white papers on counterair, counterinformation, strategic and C<sup>2</sup> attack, close air support, surveillance and reconnaissance (S&R) real-time integration, S & R information operations, and space S & R fusion.

<sup>5</sup> **2025** Concept, No. 900374, “Living World-wide Intelligence Base,” **2025** Concepts Database (Maxwell AFB, Ala.: Air War College/**2025**, 1996).

<sup>6</sup> **2025** Concept, No. 900446, “Automated Enemy Analysis Software,” **2025** Concepts Database (Maxwell AFB, Ala.: Air War College/**2025**, 1996).

<sup>7</sup> USAF Scientific Advisory Board, *New World Vistas: Air and Space Power for the 21<sup>st</sup> Century*, summary volume (Washington, D.C.: USAF Scientific Advisory Board, 15 December 1995), 24.

<sup>8</sup> Andrew C. Braunberg, “Data Warehouses Migrate Toward World Wide Web,” *Signal*, February 1996, 35.

<sup>9</sup> *New World Vistas*, (unpublished draft, the information applications volume), 13.

<sup>10</sup> *Ibid.*, 57.

<sup>11</sup> *Ibid.*, 8.

<sup>12</sup> *Ibid.*, 45.

<sup>13</sup> Majors Kevin N. Dunleavy and Lester C. Ferguson, “Command and Control and the Doctrinal Basis of the Theater Air Control System,” in Lt Col Albert, ed., *Concepts in Airpower for the Campaign Planner* (Maxwell AFB, Ala.: Air University Press, 1993), 135.

<sup>14</sup> *Force XXI*, 16–17.

<sup>15</sup> Sun Tzu, 140.

<sup>16</sup> Eric Horvitz and Matthew Barry, *Proceeding of the Eleventh Conference on Uncertainty in Artificial Intelligence*, Montreal, August 1995. This paper describes methods for managing the complexity of information displayed to people responsible for making high-stakes, time-critical decisions. The area of focus is time-critical applications at NASA’s Mission Control Center during Space Shuttle flights.

<sup>17</sup> Pattie Maes, Massachusetts Institute of Technology Media Laboratory, “Agents that Reduce Work and Information Overload,” Internet address: <http://pattie.www.media.mit.edu/people/pattie/CACM-94/CACM-94.pl.html>, 1 February 1996. This paper describes a new style human-computer interaction, where the computer becomes an intelligent, active and personalized collaborator using interface agents that employ artificial intelligence and learn from the user as well as other agents.

<sup>18</sup> Allen Sears and Robert Neches, Advanced Research Projects Agency, Information Technology Office, “Human Computer Interaction,” Internet address: <http://www.ito.arpa.mil/ResearchAreas/HCI.html>, 10 April 1996. This program will support effective and efficient communication between human users and computer-based systems. A key focus is on interactive agents that focus the attention of the user and the software components on critical issues for specific tasks.

<sup>19</sup> Richard Axel, “Mammals Can Recognize Thousands of Odors, Some of Which Prompt Powerful Response,” *Scientific American* 273, no. 4 (October 1995): 154–159.

<sup>20</sup> Advanced Research Projects Agency, “Computer Aided Education and Training,” Internet address: <http://www.ito.arpa.mil/ResearchAreas/CAETI.html>, 31 January 1996.

<sup>21</sup> **2025** Concept, No. 900667, “Real-time War Status Board,” **2025** Concepts Database (Maxwell AFB, Ala.: Air War College/**2025**, 1996).

<sup>22</sup> **2025** Concept, No. 900385, “3-D Holographic Battlefield Display,” **2025** Concepts Database (Maxwell AFB, Ala.: Air War College/**2025**, 1996); **2025** Concept, No. 900417, “Battlespace Awareness Holosphere,” **2025** Concepts Database (Maxwell AFB, Ala.: Air War College/**2025**, 1996); **2025** Concept, No. 900206, “Commander’s Universal [order of] Battle Display,” **2025** Concepts Database (Maxwell AFB, Ala.: Air War College/**2025**, 1996); **2025** Concept, No. 900161, “Holographic C<sup>2</sup> Sandbox,” **2025** Concepts Database (Maxwell AFB, Ala.: Air War College/**2025**, 1996); **2025** Concept, No. 900115, “Don’t Blink,” **2025** Concepts Database (Maxwell AFB, Ala.: Air War College/**2025**, 1996).

<sup>23</sup> *New World Vistas*, (unpublished draft, the information applications volume), 14.

<sup>24</sup> *Ibid.*, 16; Kristin Leutwyler, “Calculating with DNA,” *Scientific American* 273, no. 3 (September 1995):18.

<sup>25</sup> David A. Patterson, “Microprocessors in 2020,” *Scientific American* 273, no. 3 (September 1995): 48.

<sup>26</sup> Pattie Maes, “Intelligent Software,” *Scientific American* 273, no. 3 (September 1995): 66.

<sup>27</sup> *New World Vistas*, (unpublished draft, the information technology volume), 38–41.

<sup>28</sup> E. B. Baatz, “Making Brain Waves,” *CIO*, 15 January 1996, 24.

<sup>29</sup> Lt Col Robert J. Wood, “Information Engineering: The Foundation of Information Warfare,” research report (Maxwell AFB, Ala.: Air War College, April 1995), 39; John G. Kemeny and J. Laurie Snell, *Finite Markov Chains* (Princeton, N. J.: Van Nostrand, 1960), 24–25, 182–184.

<sup>30</sup> Bart Kosko, *Fuzzy Thinking* (New York: Hyperion, 1993), 222–235.

<sup>31</sup> Maj Glenn E. James, United States Air Force Phillips Laboratory, Edwards AFB, Calif., interviewed during visit to Air Command and Staff College, Maxwell AFB, Ala., 8 March 1996;

J. A. Dewar et al., "Non-Monotonicity, Chaos, and Combat Models," RAND Library Collection, Santa Monica, Calif.: RAND, 1991.

<sup>32</sup> Maj Glenn E. James, "Chaos Theory: The Essentials for Military Applications," in *Theater Air Campaign Studies*, (Maxwell AFB, Ala.: Air Command and Staff College, 1996): 38.

<sup>33</sup> *Ibid.*, 45.

<sup>34</sup> *New World Vistas*, (unpublished draft, the human systems and biotechnology volume), Appendix M. Using EEGs to determine the state of the operator/user to determine workload and cognitive effort; *Airman Magazine* interview with Dr. Grant McMillan, Air Force Armstrong Laboratory, Internet address: <http://www.dtic.mil/airforcelink/pa/airman/0296/look.htm>, 10 February 1996. The article describes Dr. McMillan's use of EEGs to allow pilots to command a flight simulator to roll to the left or right by thinking about it.

<sup>35</sup> Daniel Magsig, "Information Warfare in the Information Age," Internet address: <http://www.seas.gwu.edu/student/dmagsig/infowar.html>, 7 February 1996, 7.

<sup>36</sup> "Public Networks Require Tailored Security Action," *Signal*, March 1996, 23–26.

<sup>37</sup> *New World Vistas*, (unpublished draft, the information technology volume), 92; Gates, 109–110.



## **Chapter 4**

### **Concept of Operations**

The chapters on required capabilities and system description detail the Wisdom Warfare architecture. It is a collection of robust, highly interconnected, smart nodes providing information flow and advice tailored by each user. Nodes and the system learn from their experience and the experience of nodes used by people in analogous situations. These features make the architecture useful throughout the spectrum of conflict and in a variety of alternate futures.

Air power must prepare to face everything from peace to full-scale war in 2025. The Wisdom Warfare architecture helps achieve that broad capability. At the operational level, the architecture provides fully fused intelligence, coordinated logistics, and a variety of courses of action. At the tactical level, it can even provide instructions to technicians. The Wisdom Warfare architecture particularly helps staffs perform their roles in support of commanders.

Personnel staffs can track the status of each person involved in a battle through computers woven into each warrior's clothing.<sup>1</sup> This includes information on name, rank, unit, specialty, health status, and location. Commanders can see the information at any level of organization. In addition, staffs can communicate with troops to educate them on the mission and the cultures involved.

Intelligence staffs will conduct operations in a dramatically different way when compared to today. During peacetime, the system will collect global information and intelligence staffs will construct models to forecast COAs of potential enemies. Intelligence, surveillance, and reconnaissance data are fused with a variety of digitized maps, political factors, cultural guides, opinions from area experts, industrial data, current and forecasted weather, enemy doctrine, and objectives. As hostilities become imminent or erupt, the system will use intelligent software agents to get fused intelligence to the proper nodes that will minimize human delays during conflict. Each user will then use his forecasting and decision-making tools to turn knowledge into good decisions. Forecasting tools will also help determine where collection assets will find the most useful information so they collect data in the most efficient way.

Operations staffs also benefit from the architecture. Before conflicts, the architecture uses several models to determine the most likely enemy centers of gravity.<sup>2</sup> It allows operations staffs to run dozens of friendly COAs against the enemy. Plans can include a variety of force packages to respond to the scenarios. In evaluating the plans, the commander determines the criteria and weights. The architecture then evaluates the plans. For instance, criteria could include

- ability to achieve national objectives
- ability to achieve theater objectives
- contribution to a better state of peace
- casualties to our side
- casualties to the enemy
- estimate of collateral damage
- time to complete the campaign
- logistics feasibility
- cost

The architecture's speed will allow staffs to generate many more plans than today. This method means they can more easily pull a plan off the shelf that is analogous to a crisis when it erupts. All this helps guard against the chance of surprise and maximizes preparedness. However, air power planners should not forget the axiom of Helmuth von Moltke the elder: "No plan of operations survives the first collision with the main body of the enemy."<sup>3</sup>

When conflict erupts, the architecture also provides fast adjustment of existing plans. Its ability to rapidly develop a variety of new COAs will be useful. Once the plans are adjusted, the architecture can automatically issue orders to deploy force packages as directed by the commander. The orders can include situation briefs, cultural briefs, and logistics instructions. The Wisdom Warfare architecture's forecasting tools and decision-making aids help manage the large amounts of information flowing in the twenty-first century battlespace.

Logistics staffs will also benefit. Like the intelligence staffs, logistics planners will spend time before conflict in building forecasting and decision-making tools. As operations plans are developed, they will automatically be fed to the logistics staffs. The decision-making tools will then help them construct the best logistics plans. In addition, materiel status-like location and serviceability will be immediately available.

Once plans are made, they will be used by all warriors. The architecture enhances war fighting by putting forecasting and decision-making tools in the warriors' hands. However, it will be just as important to have full integration of the warrior with the system. For instance, every warrior could access information by smart glasses or contact lenses and control his equipment with advanced EEGs.

The architecture provides tools to enhance knowledge and wisdom at all levels. It is best developed in peacetime by honing its operation through feedback from exercises and day-to-day operations. This is how decision makers will build confidence in the system. The architecture also aids in training and military education.<sup>4</sup> This is not a system that will be born in 2025. It is a system that must grow to maturity by 2025.

The US military can use the Wisdom Warfare architecture in a variety of futures and in the entire spectrum of military operations. A short story in appendix C illustrates a scenario in a low-intensity conflict in 2025. It helps create a picture of what Wisdom Warfare can do in 2025.

### Notes

<sup>1</sup> **2025** Concept, No. 900572, “Plastic Computing,” **2025** Concepts Database (Maxwell AFB, Ala.: Air War College/**2025**, 1996); **2025** Concept, No. 900490, “Crewman’s Data Vest,” **2025** Concepts Database (Maxwell AFB, Ala.: Air War College/**2025**, 1996); Nicholas Negroponte, “Wearable Computing,” *Wired*, December 1995, 256.

<sup>2</sup> See, for example, John Warden, “The Enemy as a System,” *Strategic Studies Course Book*, vol. 2 (Maxwell AFB, Ala.: Air Command and Staff College, 1995), 437–452; Paul Moscarelli, “Operational Analysis: An Overview,” in *Strategic Studies Course Book*, vol. 2, 522–530; Jason Barlow, “Strategic Paralysis: An Airpower Theory for the Present,” in *Strategic Studies Course Book*, vol. 2, 453.

<sup>3</sup> Helmuth Graf von Moltke, *Moltke on the Art of War*, ed. Daniel J. Hughes, trans. Daniel J. Hughes and Harry Bell (Novato, Calif.: Presidio, 1993), viii.

<sup>4</sup> Kelley, 9.

## Chapter 5

### Investigation Recommendations

The architecture described in this paper cannot be for *air power* only. Realizing the goal of Wisdom Warfare requires the integration of all knowledge sources and core competencies of each service. In a word, it must be *joint*. The architecture must serve the needs of all service components and unified commands. It must be developed and fielded as one common system, providing knowledge and wisdom to the warrior across all levels of war and through the full spectrum of conflict. It must also permit easy integration of coalition or alliance partners, when necessary. This will obviously place a greater burden on the system's security feature, but it should also force reconsideration of the way information is classified and released to foreign military leaders.

The continuing revolution in information technology makes the capabilities described in this architecture possible. However, a revolution in military affairs is not complete until the new technology is applied in combination with new doctrine and organizational changes.<sup>1</sup> They are needed to achieve the synergistic effects of combining intelligence, surveillance, reconnaissance, weather, navigation, communications, and computers. They will also provide the proper environment to train and grow "info-warriors."

New doctrine and organization will have to overcome institutional biases and orchestrate the development of a common architecture across service, government, and commercial sector lines. The DOD must leverage the commercial market's lead in information technology development. The DOD will not need to invest substantial sums to achieve the desired capabilities as the US completes its transition to a Third Wave society.<sup>2</sup> This is not to say the DOD should passively accept whatever information technology the commercial market produces. Rather, the DOD should be an active participant in influencing the direction of certain information technology research and development.

### **Knowledge and Wisdom Recommendations**

The exponential growth of communications and networking technology in the commercial sector will provide the military with cost-effective connectivity around the globe.<sup>3</sup> The military must invest in providing secure, reliable communications links between ground nodes and fast moving platforms. Lightweight, multibeam, broadband, phased-array antennas and small, low-power communications packages are two specific areas requiring further development.

Security must be integrated throughout the architecture. Cryptography and multilevel security operating software can provide high levels of security to individual systems; however, new techniques must be developed to ensure the survivability and assurance of the architecture itself.

New approaches in computing such as DNA-based and optical computing offer the potential of revolutionary advances in processing speed and parallelism.

Advances in storage capacity are required to manage the billions of bits flowing through the architecture. Emerging storage technologies such as holographic memories, vertical block line storage, and data warehousing offer possible alternatives.<sup>4</sup>

Fusion research is important in the infosphere. High-impact artificial intelligence applications require coordinated efforts of research and development across several areas of computer science. Building these systems will require combining AI methods with non-AI approaches and embedding AI technology within larger systems.<sup>5</sup>

DOD should research military applications of AI, intelligent software agents, neural networks, fuzzy cognitive maps, chaos theory, and Markov chains. Additionally, the DOD should concentrate on information technologies that encourage open systems, dual-use defense and commercial technologies, software advances which improve on object-oriented code, adaptive algorithms, pattern recognition, and automatic target recognition.

### **Human System Integration Recommendations**

The technologies needed in the *human system integration* component will require the Air Force to focus research on areas unique to military missions while maximizing its leverage on the advances in the commercial world. Supporting technologies in this area are improvements to human sensory capabilities and technologies that improve the human cognitive capabilities. These technologies will allow the human and system to work with one another to maintain the best situational awareness possible. The Air Force must also pursue an effective training program for humans and systems to achieve good integration and provide the best environment for making decisions. Interactive and learning displays will be a key component of the information operations systems of 2025. To improve the ability of the decision makers to receive the

information necessary to make decisions, the Air Force must continue to advance the capabilities of HSI technology.

### **Cost**

The most cost-effective options will likely follow the advances in commercial development and application of technologies in computational, networking, and communications areas. The key technologies in the previous section fall into three general categories.<sup>6</sup> They are depicted in table 1.

The first category includes those technologies developed by the commercial world and not likely to need significant military investment. The second category consists of high-risk technologies with potentially greater long-term payoff but not worth military investment at this stage. The final category contains those with good payoff but which requires military investment at this time.

In addition, the armed forces will need to augment these areas where the military has unique requirements (i.e., multilevel security, high-data-rate encryption, anti-jam, and low probability of intercept communications).



**Table 1**

**Technology Investment Opportunities**

Commercial Development	High Risk	Military Investment Areas
<ul style="list-style-type: none"> <li>• Neural networks</li> <li>• Massively parallel —processors</li> <li>• Superscalar processors</li> <li>• Pipelined processors</li> <li>• Holographic memory</li> <li>• Vertical block line storage</li> <li>• Advanced data —compression</li> <li>• Global fiber networks</li> <li>• High-capacity satellite —communications</li> <li>• Optical interconnects</li> <li>• Image mosaics</li> <li>• Holographic displays</li> <li>• Glasses as displays</li> <li>• Contact lenses as displays</li> <li>• Virtual reality</li> <li>• Software agents to sort, — filter, and distribute — information from a very — large number of sources</li> <li>• Evolving software to —automatically recode —itself to achieve user- —selected goals</li> <li>• Artificial intelligence to —provide predictive tools</li> </ul>	<ul style="list-style-type: none"> <li>• Photonic processors</li> <li>• DNA processors</li> <li>• Atomic level storage —devices</li> <li>• Displays that incorporate —all five human senses</li> </ul>	<ul style="list-style-type: none"> <li>• Military applications for — intelligent software agents</li> <li>• Military applications for — artificial intelligence</li> </ul>

The topic of cost for an architecture that is as far-reaching as the one described in this paper is a daunting task even for the experienced cost estimator. The trends in technology improvements show the armed forces can leverage commercial technology for most areas and use scarce research and development dollars on those high-payoff areas that have unique military requirements. The trends are clear. The computational, communications, displays, and software

technologies will provide the capability required and at costs that will be affordable for the armed forces.

An often-cited reference on the historic and predicted costs of computational power is Hans Moravec's book, *Mind Children: The Future of Robot and Human Intelligence*. This reference states computers capable of processing  $10^{14}$  bits per second will "be available in a \$10 million supercomputer before 2010 and in a \$1,000 personal computer by 2030."<sup>7</sup> Even these astounding predictions are shown to be conservative when updated with recent computer advances. This supercomputer is almost a reality today and may be found in a personal computer early next century.<sup>8</sup> The computational power predicted to be available in 2025 will be sufficient to handle the needs of the architecture at extremely reasonable costs.

The advances in communication technology will also allow the architecture to be realized at reasonable costs. Fiber networks are growing exponentially. Over the last 15–20 years the carrying capacity of fiber networks has increased about 10,000 fold and is expected to continue to grow in the future.<sup>9</sup> Similarly, direct broadcast service (DBS) has grown tremendously. The current DBS systems can transmit greater than 64 trillion bits of information per day to large portions of the earth. The military has already recognized the benefits of DBS systems and is pursuing the placement of this technology on military communication satellites by the turn of the next century.

Due to competition and advances in technology, costs of information systems are coming down every year.<sup>10</sup> Besides these reductions, costs savings will be realized through transmission protocols like asynchronous transfer mode which allow users to be charged for only the portion of the communication link they use.

Current programs expect to develop military radios in the next four years that require 60 percent less power, are 3-5 times more capable, are one-third the physical size, and cost less than today's models.<sup>11</sup> Given the continuation of these improvements, it is expected that affordable methods to get needed information or to communicate to anyone will be available anywhere on the globe.<sup>12</sup>

Two other areas that may be cost drivers are display technology and intelligent software development. It is expected both of these areas will be pushed by effort from entertainment and commercial industries. In his book *Being Digital*, Nicholas Negroponte points out: "Games companies are driving display technology so hard that virtual reality will become a reality at very low cost."<sup>13</sup> This statement becomes self-evident when considering the following examples: in 1994 Nintendo announced the \$199 virtual reality game called "Virtual Boy" and in 1995 Sony introduced the \$200 "Playstation" that has 10 times the computational power of the fastest Intel processor.<sup>14</sup> It is safe to state the necessary display technologies will be available at reasonable costs in the year 2025.

Intelligent software and AI should benefit in a similar fashion. The recent advances in AI provide optimism for the future.<sup>15</sup> An example is a project at the Microelectronics and Computing Corporation where a commonsense knowledge base is being created for computers.<sup>16</sup> The large benefit of this type of system is once the core knowledge base is established it is believed the system can begin to assimilate information on its own—in the ultimate it could reach the point where the system will learn as fast as information is fed to it.<sup>17</sup> Efforts to digitize the Library of Congress have already begun.<sup>18</sup> One can imagine large parts of the library being digitized by 2025 and easily feeding this tremendous amount of information to a commonsense knowledge base at data rates of many trillions of bits per second. Costs will also be reduced

through leveraging commercial improvements in systems that create information profiles and “put information at your fingertips.”<sup>19</sup>

With an understanding of these advances it can be assumed technology advances in intelligent software will provide the capabilities required by the Wisdom Warfare architecture and will be available at reasonable costs.

### **Schedule**

Given the focus on maximizing leverage of commercial systems, the next few paragraphs describe a three-phase schedule to reaching the Wisdom Warfare architecture.

**Planning Phase (present to 2005).** Phase I consists of three main tasks. The first task is the systems engineering development of the road map and blueprints for the open architecture that will support Wisdom Warfare. This task includes in the identification and development of the standards for the “open systems” which will allow the architecture to be flexible and capable of rapid change and growth,<sup>20</sup> identification of the unique military requirements that will not be met by commercial practices and ensuring their development does not limit use in the open systems architecture the identification of current and planned systems (military and commercial) that will evolve and migrate into the Wisdom Warfare architecture. This effort will be an extension and continuation of the current DOD and Intelligence Community Intelligence Systems Board migration study.<sup>21</sup>

The second task is the development of forecasting tools, which is expected to be a “long-pole” system.<sup>22</sup> This task also includes the development of the initial databases that will evolve into the learning databases the Wisdom Warfare architecture requires.

The third task involves determination of any organizational and attitude changes necessary for success. This is expected to involve a concerted effort at changing service and personal attitudes to allow the architecture to be effective. The personalities and organizational inertia existing today have already caused significant roadblocks to the achievement of an integrated architecture.<sup>23</sup> This task will also address the training requirements needed to successfully develop the human and system integration requirements for Wisdom Warfare, once review commercial industry lessons learned in the control of cost and the use of commercial software products.<sup>24</sup> The goal of this phase is to establish the foundation for the architecture and create the organizations and technologies that will carry out the road map and blueprints through the next two phases.

**Phase II: Initial Ascent (2005 to 2015).** The first task is the continued evolution of the prototype programs initiated in Phase I. The modeling and forecasting tools will be enhanced with advances in areas such as chaos theory, fuzzy cognitive maps, and AI. Taking advantage of a new understanding about the human decision-making process, the initial attempts at genius ghosting will be undertaken in this phase. The prototypes of advanced fusion systems will be evolved and continue to improve the timeliness and diversity of data fusing. The databases will continue to evolve and develop additional linkages. New display technologies will be integrated into the systems as holographic and virtual reality displays are improved and reduced in cost due to advances in electronic technologies and the personal entertainment fields.<sup>25</sup> This area will also be enhanced through the improved understanding of human cognitive skills to allow focus on the areas that require HSI.

Initial prototypes will be fielded. Peacetime logistics operations will most likely be the best place to start. Commercial development, such as global package delivery, is likely to continue

here because of the advantages of the architecture and technologies. The armed forces can leverage this commercial development. The goal of this phase is to continue evolving the architecture and gain momentum to allow the third phase to carry the architecture to the Wisdom Warfare level.

**Phase III: Final Ascent (2015–2025+).** The first task of this phase is to complete the *knowledge* level of the architecture. This includes the evolution of the databases and fusion systems to provide the decision makers the ability to understand the information and intelligence that is available. During this phase several things will occur: the architecture will evolve to the point where it truly learns; procedures will be formalized; timelines for planning and execution will be reduced; and the core communications architecture will begin to solidify but will remain flexible for continued change and growth. With this accomplished, the decision makers can successfully employ the decision tools provided at the *wisdom* level of the architecture—the second task of this phase. The decision tools will mature and become part of the training and education system to allow an understanding of the systems, effective HSI, and improved decision-making processes. Once decision makers are comfortable with these tools and the actions and decisions the systems are making they will have achieved a Wisdom Warfare capability.

Is Wisdom Warfare possible in 2025? The answer is most certainly yes. The continuing revolution in information technology will make the capabilities described in this architecture possible. However, the leaders of today must commit to a common system that provides knowledge and wisdom across all levels of war and through the full spectrum of conflict. Such a system is affordable. By leveraging commercial advances in most technologies and using scarce

military research and development dollars on others, the war fighters of the future can have the tools to conduct Wisdom Warfare.

## Notes

<sup>1</sup> Jeffery McKittrick et al., “The Revolution in Military Affairs,” in Barry R. Schneider and Lawrence E. Grinter, eds., *Battlefield of the Future: 21st Century Warfare Issues* (Maxwell AFB, Ala.: Air University Press, September 1995), 65.

<sup>2</sup> Alvin and Heidi Toffler, *War and Anti-War* (New York: Warner Books, Inc., 1993), 64–72.

<sup>3</sup> John L. Peterson, *The Road to 2015: Profiles of the Future* (Corte Madera, Calif.: Waite Group Press, 1994), 33–38.

<sup>4</sup> “Chip Architecture Removes Signal Processing Bottleneck,” *Signal*, February 1996, 31; *SPACECAST 2020*, Surveillance and Reconnaissance Volume (Maxwell AFB, Ala.: Air University, 1994), 15; Andrew C. Braunberg, “Data Warehouses Migrate Toward World Wide Web,” *Signal*, February 1996, 35.

<sup>5</sup> USAF Scientific Advisory Board, *New World Vistas: Air and Space Power for the 21<sup>st</sup> Century* (unpublished draft, the information technology volume, 15 December 1995), 65.

<sup>6</sup> Maj Gregg Gunsch, Air Force Institute of Technology, to Maj Charles Williamson, Air Command and Staff College student, electronic mail, subject: AFIT Assessment of Key Technologies, 22 March 1995.

<sup>7</sup> Hans Moravec, *Mind Children: The Future of Robot and Human Intelligence* (Cambridge, MA: Harvard University Press, 1988), 68.

<sup>8</sup> Sarnoff Research Center, “Exploiting the Consumer Digital Systems (CDS) Revolution,” briefing to Lt Gen Jay Kelley, Air University commander, Maxwell AFB, Ala., 24 March, 1994.

<sup>9</sup> Peterson, 35-36; David Voss, “You Say You Want More Bandwidth?” *Wired*, July 1995, 64.

<sup>10</sup> Bill Gates, *The Road Ahead* (New York: Viking Penguin, 1995), 240.

<sup>11</sup> Air Force Rome Laboratory, *Speakeasy Program Briefing* (Internet address: <http://woody.c2tc.rl.af.mil:8001/Technology/Demos/SPEAKEASY>), March 1996.

<sup>12</sup> George Gilder, “Gilder Meets His Critics,” Internet address: <http://www.discovery.org/critics.html>, 29 March 1996, 1–13. This article is a portion of Mr Gilder’s book *Telecosm* to be published by Simon & Schuster in 1996.

<sup>13</sup> Nicholas Negroponte, *Being Digital* (New York: Vintage Books, 1996), 83.

<sup>14</sup> Ibid.

<sup>15</sup> Edward A. Feigenbaum, chief scientist, US Air Force, “The Intelligent Use of Machine Intelligence,” *Crosstalk*, August 1995, 10–13.

<sup>16</sup> Peterson, 41–43; Negroponte, 155–156.

<sup>17</sup> Douglas B. Lenat, “Artificial Intelligence,” *Scientific American* 273, no. 3 (September 1995): 64; Peterson, 41–42.

<sup>18</sup> “Library of Congress Opens Digital Library Visitor Center,” *Library Journal* 119, no. 19 (15 November, 1994): 21.

<sup>19</sup> Cable News Network, “CNN at Work,” Internet address: [http://www.intel.com/comm-net/cnn\\_work/index.html](http://www.intel.com/comm-net/cnn_work/index.html), 14 February 1996.

<sup>20</sup> Negroponte, 47.

<sup>21</sup> “INTEL04: Integrate Intelligence Community Information Management Systems,” Internet address: <http://www.odci.gov/ic/npr/intel04.html>, 10 April 1996.

<sup>22</sup> Gunsch electronic mail.

<sup>23</sup> Assessor’s comment to Information Operations briefing, Air University, Maxwell AFB, Ala., February 1996.

<sup>24</sup> Salvatore Salamone, “Control Software Costs,” *Byte*, April 1995, 75–82.

<sup>25</sup> David Pescovitz, “The Future of Holography,” *Wired*, July 1995, 60.



## Appendix A

### Acronyms and Abbreviations

AI	artificial intelligence
BDA	battle damage assessment
C <sup>2</sup>	command and control
COA	course of action
DBS	direct broadcast service
DNA	deoxyribonucleic acid
EEG	electroencephalograph
FCM	fuzzy cognitive map
GCCS	global command and control system
HSI	human system integration
HUMINT	human intelligence
IAT	information access technology
IMINT	imagery intelligence
ISA	intelligent software agent
MASINT	measure and signature intelligence
MOD/SIM	modeling and simulation
NCO	non-commissioned officer
NRT	Near Real Time
OODA	observe, orient, decide, and act
OAS	Organization of American States
PDA	personal digital assistant

SIGINT	signals intelligence
SURV	surveillance
UN	United Nations
US	United States
WMD	weapons of mass destruction

## Glossary

**Architecture:** A framework or structure that portrays relationships among all the elements of the subject force, system, or activity.<sup>1</sup>

**Battlespace:** Area of concentration or concern; typically the workspace. Dependent on the scope of the individual's effort and level in the system hierarchy.

**Command and control:** The exercise of authority and direction by a properly designated commander over assigned forces in the accomplishment of the mission.<sup>2</sup>

**Information:** Data and instructions.<sup>3</sup>

**Information dominance:** The state where one adversary possesses almost complete battlespace awareness, while the other adversary is cut off from almost all information sources.<sup>4</sup> Also information superiority.

**Information operations:** Any action involving the acquisition, transmission, storage, or transformation of information that enhances the employment of military operations.<sup>5</sup>

**Information superiority:** See information dominance.

**Information system:** The organized collection, processing, transmission, and dissemination of information, in accordance with defined procedures, whether automated or manual. In Information Warfare, this includes the entire infrastructure, organization, and components that collect, process, store, transmit, display, and disseminate information.<sup>6</sup>

**Information warfare:** Any action to deny, exploit, corrupt, or destroy the enemy's information and its functions; protecting ourselves against those actions; and exploiting our own military information functions.<sup>7</sup>

**Knowledge:** The fusion, correlation, and association of related intelligence information leading to understanding.

**Offensive counterinformation:** Actions against the adversary's information functions.<sup>8</sup>

**Wisdom:** Discernment based not only on factual knowledge but on judgment and insight.<sup>9</sup>

### Notes

<sup>1</sup> Joint Publication 1-02, *DOD Dictionary of Military and Associated Terms*, 23 March 1994, 32.

<sup>2</sup> Joint Publication 1-02, 78.

<sup>3</sup> Department of the Air Force, *Cornerstones of Information Warfare*, 1995, Definitions.

<sup>4</sup> Stewart E. Johnson and Martin C. Libicki, *Dominant Battlespace Knowledge: The Winning Edge* (Washington, D.C.: National Defense University Press, 1995), 27-58.

<sup>5</sup> *Cornerstones*, Definitions.

<sup>6</sup> DoD Directive S-3600.1 [draft]

<sup>7</sup> *Cornerstones*, Definitions.

<sup>8</sup> Ibid.

<sup>9</sup> Philip B. Gove, editor in chief, *Webster's Third New International Dictionary, Unabridged* (Springfield, Massachusetts: Merriam-Webster, 1986), 2624.

## **Appendix B**

### **Operation Swift Split**

On the airplane again. Lt Gen Edward F. Barnes looked at his watch: 0900, 8 September 2025. “We’ll be in the middle of the shooting in three hours,” he thought. He looked up at the five-tense warriors sitting with him on the modified 797. He was glad to have them as his staff. Each one knew decisions were measured in someone else’s blood.

General Barnes couldn’t kick his old habit. Their computers knew what his computer knew, but habit made him tell them anyway: “Guyana and Surinam are at it again. Both countries have vacillated between democracy and military juntas since about 2010. Since then, they have argued over the hydropower of the New River.<sup>1</sup> You know the last border dispute ended only two years ago. Secretary of State Hillary Druary told me three days ago she had finished secret negotiations with the UN and OAS to prepare for armed intervention by the US if peace talks failed. Fighting broke out just over four hours ago. Each side has gained territory, and both countries have committed terrorist acts against civilians in Venezuela and Brazil. The situation could easily spin out of control. Our objectives are to separate the armies and reestablish peace based on the last agreement. Let’s go to the board.”

Col Frank Whorton was the personnel chief: “This is the first time we’ve used the automatic personnel status reports in a shooting match, but they’re working well. The computer woven into

each warrior's clothing gives us their name, rank, unit, specialty, health status, and location.<sup>2</sup> You can see the information split out or lumped together at any level of organization. In addition, a random poll of the troops and leaders has assessed morale, understanding of our mission, and understanding of the cultures we're facing."

General Barnes turned to Brig Gen Bill Hladek. "OK, -2, whacha got?" "Well, sir," General Hladek began, "the screen pretty much sums up the intelligence situation. First off, the computer's showing only a 2 percent probability of WMDs in either country. You know the system will almost never give a straight 100 percent or 0 percent answer because it forces us to take responsibility for decisions. My staff and I ran formal reviews of the intelligence synthesis system eight months ago and validated the four decision-making models listed on your screen. Per standard procedures, we've established links with every US embassy in Latin America, the State Department, OAS Headquarters, UN Headquarters, and professors from eight universities in the US and Latin America on contract as consultants. Their recommendations are starting to pour in. They got almost the same briefing as the one you and the National Security Council gave President Stonerock two hours ago. In addition, 14 journals on South American studies were scanned again and their information updated in our databases. Finally, we added 17 reconnaissance platforms to the three already over the area.<sup>3</sup> At this point, we have dispositions on approximately 86 percent of the enemy forces down there, and we expect a 97 percent disposition before our forces touch down. We've pinpointed their command posts down to the company level and located all their armor and mechanized forces. The system identified one hole we're trying to fill. We know your intel plan says you want to know where government leaders are, but we haven't found the Guyanan 'President-for-Life' yet."

Brig Gen Chip Borud was the joint task force operations officer. He spoke next: “Well, folks, here’s the ops situation. We started planning three days ago. We set H-hour when the shooting started,, then implemented Joint Operations Plan 14.76 at H+3 after getting the OK from Secretary of Defense Warden. Mission shred-outs for each unit were briefed in mobility holding areas and on the airplanes while flying in. Culture briefings pointed out about 25 percent of the population is Hindu and about 20 percent is Muslim.<sup>4</sup> Cultural and religious taboos were briefed to help enhance legitimacy for peace enforcement after we stop the fighting. Dutch is the official language in Surinam,<sup>5</sup> so every warrior on the ground is wearing his universal language translator in his ear.”<sup>6</sup>

General Borud’s staff had tested the Wisdom Warrior Advisor System extensively. (The NCOs immediately called the system “the Wiz” and the name stuck.) While putting together the deliberate plan for this theater, General Borud had split his staff into two competing teams. The first team developed courses of action using the now-ancient Global Command and Control System (GCCS) and the second team developed plans using Wiz. Then they ran 400 simulations with the competing plans. For the first hours of the campaign, neither plan had an edge. However, after eight hours, the performance of the Wiz plans pulled way ahead by every measure. First off, Wiz’s plans were superior. The plans included factors not considered by the GCCS team and Wiz’s team achieved better economy of force. Secondly, information overload killed the GCCS team. The GCCS team discovered human memories and quickly developed gaps, especially under stress. Sometimes those gaps took a long time to fill, even when the whole team worked on them. By contrast, the team with Wiz developed about the same number of memory gaps but could fill them almost instantly just by asking Wiz. Wiz owed a lot to the GCCS concepts but finally put GCCS to rest.

In developing the crisis plan for this campaign, Borud and his team gave Wiz the campaign and national objectives. Then they told Wiz to design campaigns using the philosophies of many commanders and theorists. Sun Tzu in ancient China, Jomini and Clausewitz after Napoleon, MacArthur in World War I, Bradley and Halsey in World War II, Dayan in Israel's fight for Palestine, Giap in Vietnam, Horner in the Gulf War, and Wallman in the Big War of 2013.

Wiz pulled together the information in its databases and all the databases to which it was connected: digitized maps, political maps, cultural guides, industrial data, current weather and forecasts, enemy doctrine, enemy objectives, and the doctrines and capabilities of available US forces. Wiz then used several models to determine the most likely enemy centers of gravity.

Wiz determined the initial center of gravity for both countries was the King Edward VII Falls on the New River. It was the key to exploiting the hydropower potential in the area and was the objective of both countries. Wiz also pointed out our airborne and long-range air assault troops could seize the Falls faster than either Guyana or Surinam. Wiz reasoned that if we held both sides' reason for war, we could gain our initial objective to stop the fighting.

Wiz automatically ran simulations on the planned campaigns and evaluated them against the usual criteria: ability to achieve national objectives, contribution to a long-term better state of peace, casualties to our side, casualties to the enemy, estimate of collateral damage, time to complete the campaign, logistics feasibility, and cost.

General Barnes had given Borud the weights for each factor. Wiz determined Sun Tzu's style would work best overall. However, Wiz pointed out that emulating MacArthur's audacity in World War I would play well in the cultures of Guyana and Surinam and would be useful for establishing legitimacy of UN forces in enforcing the peace.

Borud told all this to Barnes and held his breath. Borud knew this was the point at which Barnes always proved why he was in charge. Barnes was a genius. He trusted Wiz. He appreciated using something much like it when he worked logistics on the joint staff in the Big War just 12 years ago. But Barnes knew no computer could replace him. Barnes could feel the battlefield. He could smell the enemy. Barnes could taste the battle. He knew only a human can run this most human of endeavors. He wanted Wiz's help but he knew the decision was his, and his alone. Barnes closed his eyes and thought silently for several minutes. Finally, he asked, "Roxanne, what about you?"

Col Roxanne Wyant, the J-4, stirred. "General, Wiz is working the logistics just fine. It already projected the minimum and maximum force sets for the most likely scenarios needed to meet the national objectives. It has incorporated the scenarios run by the J-3 and issued orders for the minimum force set to immediately move to staging areas in the theater. It also issued warning orders for units in the maximum force set. We'll send out execution orders to them if you give the word. Wiz alerted our primary suppliers and our "just-in-time" resupply will start flowing this afternoon. Since logistics feasibility was a grading criteria for the ops planning, we have no limiting factors due to logistics in any of the plans in front of you."

General Barnes grunted. It was all being done in accordance with the standard procedures he had issued, but it was still a surprise when the computer thought two steps ahead of him, even when he had told it what steps to take.

The meeting had taken 15 minutes. He needed a cup of coffee and a few minutes to think alone, so he excused the staff. He looked at the holographic battlespace picture on his desk and zoomed in on the King Edward VII Falls. General Barnes knew that every captain in the 82d Airborne could see the same thing through the contact lenses each one wore.<sup>7</sup> "But what do I



want those great captains to do?” Barnes paced back and forth in the small cabin. After five minutes, he called the staff in, then called the secretary of defense and the president. “Mr. President, this is what we should do...”

By H+5 hours, the plane carrying Capt “Acid” Raines’ airborne company was loitering over the Caribbean along with the six other C-18s carrying the minimum force set. At H+6 hours, everyone there heard and saw President Stonerock give his objectives. Next, General Barnes appeared and briefed his intent and the outline of the campaign plan. The contact lens displays were so vivid, Captain Raines almost came to attention. Five minutes later, the brigade commander appeared and told Captain Raines to secure the northwest side of the top of the King Edward VII Falls. Raines’ Raiders had a mission.

Captain Raines asked Wiz for enemy dispositions and estimated arrival times at the falls. He then zoomed in his country display on the falls and asked Wiz for the best drop zone locations. Wiz told Raines to clarify his meaning of “best.” After Raines gave Wiz the criteria, Wiz gave Raines a choice. He could land his company together in a clearing on the southeast side of the falls and take boats across to the northwest side. Wiz said this gave him a 90 percent probability he could have his whole company in place one hour before the time Wiz estimated the enemy would arrive. On the other hand, Raines could jump his company into a small drop zone on the northwest side, closer to his final position, but with multiple aircraft passes. That meant he could have men in place three hours before the enemy got there but Wiz said there was a 40 percent chance he would lose 15 men in the hazardous drop into the jungle. Raines would rather have less time to dig in together than have more time with some men dead. He picked the clear zone across the river.

Raines had his platoon sergeants look at the plans. No one suggested changes so Raines sent them to the brigade commander. Wiz noted another company was dropping at the same place so the brigade commander gave Raines priority. Wiz passed the word to both company commanders and used its airspace management routines to vector the transport planes.<sup>8</sup> It would take an hour to fly to the drop zone. Raines decided some practice would help so he had Wiz display the drop, river crossing, and platoon maneuvers in double real time on each man's display, then turned the men over to the platoon sergeants. At H+7 hours, Raines' Raiders started their drop.

It took six days. It really took only four days to separate the armies but it took two more days to convince the Guyanan "President-for-life" to join the peace talks. They fulfilled the prophecy: faster operations mean more effectiveness.<sup>9</sup>

### Notes

<sup>1</sup> Central Intelligence Agency, *The World Factbook 1995*, 399.

<sup>2</sup> **2025** Concept, No. 900572, "Plastic Computing," **2025** Concepts Database (Maxwell AFB, Ala.: Air War College/**2025**, 1996); **2025** Concept, No. 900490, "Crewman's Data Vest," **2025** Concepts Database (Maxwell AFB, Ala.: Air War College/**2025**, 1996).

<sup>3</sup> **2025** Concept, No. 900552, "On-demand Tactical Recce Satellite Constellation," **2025** Concepts Database (Maxwell AFB, Ala.: Air War College/**2025**, 1996).

<sup>4</sup> Central Intelligence Agency, 399.

<sup>5</sup> Ibid.

<sup>6</sup> **2025** Concept, No. 900340, "Universal Language Translator," **2025** Concepts Database (Maxwell AFB, Ala.: Air War College/**2025**, 1996).

<sup>7</sup> **2025** Concept, No. 900263, "The All Seeing Warrior," **2025** Concepts Database (Maxwell AFB, Ala.: Air War College/**2025**, 1996).

<sup>8</sup> **2025** Concept, No. 900526, "Space-Based Airspace Control & Deconfliction System," **2025** Concepts Database (Maxwell AFB, Ala.: Air War College/**2025**, 1996).

<sup>9</sup> USAF Scientific Advisory Board, *New World Vistas: Air and Space Power for the 21<sup>st</sup> Century*, summary volume (Washington, D.C.: USAF Scientific Advisory Board, 15 December 1995), 6.

## Credits

1. Illustrations of Clausewitz, Sun Tzu, and Napoleon in figure 3-3 courtesy of Daniel M. Armstrong, L. Susan Fair, and Steven C. Garst, artists at Air University Press, Maxwell Air Force Base, Alabama.
2. Globe graphic in figure 3-2 courtesy of Maj Larry Adair, USAF, student at Air Command and Staff College, Maxwell Air Force Base, Alabama.
3. Holographic battlespace in figure 3-7 courtesy of Air Force Institute of Technology.
4. Figures 1-0, 2-3, 3-4, and 3-6 contain clipart from Microsoft Clipart Gallery © 1995 with courtesy from Microsoft Corp.
5. Figure 3-5 contains clipart from Federal Clip Art © 95 with courtesy from One Mile Up, Inc.

## *Bibliography*

- 2025 Concept Database Maxwell AFB, Ala.: Air War College/2025, 1996.
- Advanced Research Projects Agency. "Computer Aided Education and Training." Internet address: <http://www.ito.arpa.mil/ResearchAreas/CAETI.html>, 31 January 1996.
- Air Force Rome Laboratory. "Speakeasy Program Briefing." Internet address: <http://woody.c2tc.rl.af.mil:8001/Technology/Demos/SPEAKEASY>, March 1996.
- Axel, Richard. "Mammals Can Recognize Thousands of Odors, Some of Which Prompt Powerful Response." *Scientific American* 273, no. 4, October 1995.
- Baatz, E. B. "Making Brain Waves." *CIO*, 15 January 1996.
- Barlow, Jason. "Strategic Paralysis: An Airpower Theory for the Present." *Strategic Studies Course Book 2* Maxwell AFB, Ala.: Air Command and Staff College, 1995.
- Braunberg, Andrew C. "Data Warehouses Migrate Toward World Wide Web." *Signal*, February 1996.
- Cable News Network. "CNN at Work." Internet address: [http://www.intel.com/comm-net/cnn\\_work/index.html](http://www.intel.com/comm-net/cnn_work/index.html), 14 February 1996.
- Central Intelligence Agency. *The World Factbook 1995*.
- The Chicago Manual of Style. 14<sup>th</sup> ed. Chicago: The University of Chicago Press, 1993.
- "Chip Architecture Removes Signal Processing Bottleneck." *Signal*, February 1996.
- College of Aerospace Doctrine, Research, and Education. *AU Press Author Guide*. Maxwell AFB, Ala.: Air University Press, March 1995.
- AU Press Style Guide for Writers & Editors*. Maxwell AFB, Ala.: Air University Press, December 1994.
- Compton's Interactive Encyclopedia*, 1994 ed., s.v. "human brain."
- Department of the Air Force. *Air Force Executive Guidance*. December 1995.
- \_\_\_\_\_. *Cornerstones of Information Warfare*. 1995.
- Department of the Army. *Force XXI*. 15 January 1995.
- Dewar, J. A., et al. "Non-Monotonicity, Chaos, and Combat Models." RAND Library Collection, Santa Monica, Calif.: RAND 1991.
- DOD Directive S-3600.1 [draft].

- Dunleavy, Maj Kevin N., and Maj Lester C. Ferguson. "Command and Control and the Doctrinal Basis of the Theater Air Control System." *Concepts in Airpower for the Campaign Planner*, Maxwell AFB, Ala.: Air University Press, 1993.
- Feigenbaum, Edward A. Chief Scientist, US Air Force, "The Intelligent Use of Machine Intelligence." *Crosstalk*, August 1995.
- Gates, Bill. *The Road Ahead*. New York: Viking Penguin, 1995.
- Gilder, George. "Gilder Meets His Critics." Internet address: <http://www.discovery.org/critics.html>, 29 March 1996.
- Gove, Phillip B., editor in chief. *Webster's Third New International Dictionary, Unabridged*. Springfield, Mass.: Merriam-Webster, 1986.
- Gunsch, Maj Gregg, Air Force Institute of Technology. Electronic mail to Maj Charles Williamson, Air Command and Staff College student. Subject: "AFIT Assessment of Key Technologies." (22 March 1995).
- Horvitz, Eric, and Matthew Barry. Proceeding of the Eleventh Conference on Uncertainty in Artificial Intelligence, Montreal, August 1995.
- Hutcherson, Lt Col Norman B. *Command and Control Warfare*. Maxwell AFB, Ala.: Air University Press, September 1994.
- "INTEL04: Integrate Intelligence Community Information Management Systems." Internet address: <http://www.odci.gov/ic/npr/intel04.html>, 10 April 1996.
- James, Maj Glenn E. "Chaos Theory: The Essentials for Military Applications." *Theater Air Campaign Studies Coursebook*. Maxwell AFB, Ala., Air Command and Staff College, 1996.
- Johnson, Stewart E., and Martin C. Libicki. *Dominant Battlespace Knowledge: The Winning Edge*. Washington, D. C.: National Defense University Press, 1995.
- Joint Publication 1-02. *DOD Dictionary of Military and Associated Terms*, 23 March 1994.
- Kelley, Lt Gen Jay W. "Brilliant Warrior." Unpublished paper, March 1996.
- Kosko, Bart. *Fuzzy Thinking*. New York: Hyperion, 1993.
- Lenat, Douglas B. "Artificial Intelligence." *Scientific American* 273, no. 3 (September 1995).
- Leutwyler, Kristin. "Calculating with DNA." *Scientific American*, 273, no. 3 (September 1995).
- "Library of Congress Opens Digital Library Visitor Center." *Library Journal* 119, no. 19 (15 November 1994).
- Maes, Pattie. "Intelligent Software." *Scientific American* 273, no. 3 (September 1995).
- . Massachusetts Institute of Technology Media Laboratory. "Agents that Reduce Work and Information Overload." Internet address: <http://pattie.www.media.mit.edu/people/pattie/CACM-94>, 1 February 1996.
- Magsig, Daniel. "Information Warfare in the Information Age." Internet address: <http://www.seas.gwu.edu/student/dmagsig/infowar.html>, 7 February 1996.

- McKenna, Pat, TSgt. "Researchers harness brain power to control jets." Internet address: <http://www.dtic.mil/airforcelink/pa/airman/0296/look.htm>, 10 February 1996.
- McKittrick, Jeffery. "The Revolution in Military Affairs," in Barry R. Schneider and Lawrence E. Grinter, eds. *Battlefield of the Future: 21st Century Warfare Issues*. Maxwell AFB, Ala.: Air University Press, September 1995.
- Moltke, Helmuth Graf von. *Moltke on the Art of War*, ed. Daniel J. Hughes, trans. Daniel J. Hughes and Harry Bell. Novato, Calif.: Presidio, 1993.
- Morovec, Hans. *Mind Children: The Future of Robot and Human Intelligence*. Cambridge, Mass.: Harvard University Press, 1988.
- Moscarelli, Paul. "Operational Analysis: An Overview." *Strategic Studies Course Book 2*. Maxwell AFB, Ala.: Air Command and Staff College, 1995.
- Negroponte, Nicholas. *Being Digital*. New York: Vintage Books, 1996.
- Nicholas Negroponte. "Affective Computing." *Wired*, April 1996.
- Patterson, David A. "Microprocessors in 2020." *Scientific American* 273, no. 3 (September 1995).
- Pescovitz, David. "The Future of Holography." *Wired*, July 1995.
- Pierce, J. R. and J. E. Karlin. "Reading Rates and the Information Rate of a Human Channel." Convention Record, IEEE WESCON, 1957.
- "Public Networks Require Tailored Security Action. *Signal*, March 1996.
- Salamone, Salvatore. "Control Software Costs." *Byte*, April 1995.
- Sarnoff Research Center. "Exploiting the Consumer Digital Systems (CDS) Revolution." Briefing to Lt Gen Jay W. Kelley, Air University commander, Maxwell AFB, Ala., 24 March 1994.
- Schwartau, Winn. *Information Warfare*. New York: Thunder's Mouth Press, 1994.
- Sears, Allen, and Robert Neches, Advanced Research Projects Agency, Information Technology Office. "Human Computer Interaction." Internet address: <http://www.ito.arpa.mil/ResearchAreas/HCI.html>, 10 April 1996.
- Spacecast 2020*. "Surveillance and Reconnaissance." Maxwell AFB, Ala.: Air University, 1994.
- Sun Tzu. *The Art of War*. Translated by Samuel B. Griffith. London: Oxford University Press, 1971.
- Toffler, Alvin and Heidi. *War and Anti-War*. New York: Warner Books, Inc., 1993.
- USAF Scientific Advisory Board. *New World Vistas: Air and Space Power for the 21<sup>st</sup> Century*. Unpublished draft, the Human Systems and Biotechnology Volume. 15 December 1995.
- . *New World Vistas: Air and Space Power for the 21<sup>st</sup> Century*. Unpublished draft, the Information Applications Volume. 15 December 1995.

- . *New World Vistas: Air and Space Power for the 21<sup>st</sup> Century*. Unpublished draft, the Information Technology Volume. 15 December 1995.
- . *New World Vistas: Air and Space Power for the 21<sup>st</sup> Century*, Summary Volume. Washington, D.C.: USAF Scientific Advisory Board, 15 December 1995.
- Voss, David. “You Say You Want More Bandwidth?” *Wired*, July 1995.
- Warden, John. “The Enemy as a System.” *Strategic Studies Course Book 2*. Maxwell AFB, Ala., Air Command and Staff College, 1995.
- Wood, Lt Col Robert J. “Information Engineering: The Foundation of Information Warfare.” Research Report, Maxwell AFB, Ala.: Air War College, April 1995.

# Worldwide Information Control System (WICS)



A Research Paper  
Presented To

Air Force *2025*

by

Capt Scott R. Maethner  
1Lt Brian I. Robinson  
1Lt Gregory E. Wood

April 1996



## **Disclaimer**

**2025** is a study designed to comply with a directive from the chief of staff of the Air Force to examine the concepts, capabilities, and technologies the United States will require to remain the dominant air and space force in the future. Presented on 17 June 1996, this report was produced in the Department of Defense school environment of academic freedom and in the interest of advancing concepts related to national defense. The views expressed in this report are those of the authors and do not reflect the official policy or position of the United States Air Force, Department of Defense, or the United States government.

This report contains fictional representations of future situations/scenarios. Any similarities to real people or events, other than those specifically cited, are unintentional and are for purposes of illustration only.

This publication has been reviewed by security and policy review authorities, is unclassified, and is cleared for public release.

## *Contents*

<i>Chapter</i>	<i>Page</i>
Disclaimer.....	ii
Illustrations .....	iv
Tables .....	v
Acknowledgments .....	vi
Executive Summary.....	vii
1 Introduction .....	1
The Problem .....	1
A Revolutionary Solution .....	4
2 Information Control in 2025.....	8
Required Capabilities.....	9
Data Collection and Processing Requirements.....	12
Artificial Intelligence Requirements.....	13
Presentation Requirements.....	15
Communications Requirements.....	16
3 System Description.....	18
Data Collection.....	18
Data Processing .....	22
Information Presentation .....	26
Communications .....	29
Countermeasures .....	31
4 Layered Access .....	34
Tactical Layer.....	35
Operational Layer.....	37
Strategic Layer.....	39
5 Enabling Technologies.....	41
Data-Collection Technologies .....	42
Data-Processing Technologies.....	43
Data-Presentation Technologies.....	43

Chapter	Page
Communications Technologies .....	44
Information-Control Technologies .....	44
6 Cost, Schedule, and Implications.....	46
7 Conclusion.....	48
Bibliography .....	49

## Illustrations

<i>Figure</i>	<i>Page</i>
1-1. OODA Loop - A Paradigm for Command and Control.....	2
2-1. WICS Mission Statement.....	9
2-2. WICS Mission Objectives.....	9
2-3. Elements of Artificial Intelligence.....	14
3-1. WICS Data Collection.....	19
3-2. WICS Processing - “Data in and Information Out” .....	22
3-3. GEO Centralized Processing Alternative .....	23
3-4. LEO-Distributed Processing Alternative.....	24

## Tables

<i>Table</i>		<i>Page</i>
1	WICS Top-Level Mission Requirements.....	11
2	Infrared Spectral Windows.....	20
3	2025 Data Collection Systems.....	21
4	LEO-Based versus GEO-Based, On-Orbit Processing.....	25
5	User Information Requirements .....	28
6	WICS System Summary .....	31
7	<i>New World Vistas</i> Technologies Applicable to WICS .....	41

## *Acknowledgments*

The authors would like to acknowledge several individuals for their contributions to this effort. We'd like to thank the auxiliary team members Capt Gerry Ashby, Capt Darren Buck, Lt Bob Carneal, and Capt Jim From for their participation, good ideas, helpful suggestions, and words of encouragement during the early days of this project when we were encouraged to discontinue our efforts. We are grateful to Dr Byron Welsh, Dr Chris Hall, and Maj Mike Roggemann for their reviews. We would also like to acknowledge Lt Col Stu Kramer and Capt Ed Pohl for their wisdom and unrestrictive advisement.

## *Executive Summary*

Information is crucial to warfare. To the war fighter, the right information at the right time and in the right format can be a tremendous military advantage. When information flows correctly it can provide a clear understanding of the developing operation. This allows commanders to make effective decisions and direct forces in a manner to meet specified objectives. Maintaining this order of battle requires a system for managing and communicating information. Today, the system is called command, control, communications, computers, and intelligence (C<sup>4</sup>I) and is often seen by those who are familiar with it as inhibiting and unresponsive. This paper develops a concept for tomorrow's system: the Worldwide Information Control System (WICS). WICS can overcome the deficiencies of today's system and can provide a revolutionary command and control capability for military operations in the possible futures of 2025. It will be capable of automatically gathering data, processing it, and presenting useful information products to the users in time for them to take appropriate actions. WICS is designed to be flexible and responsive, adapting to 2025 technologies, and providing information products that are tailored to individual users.

# Chapter 1

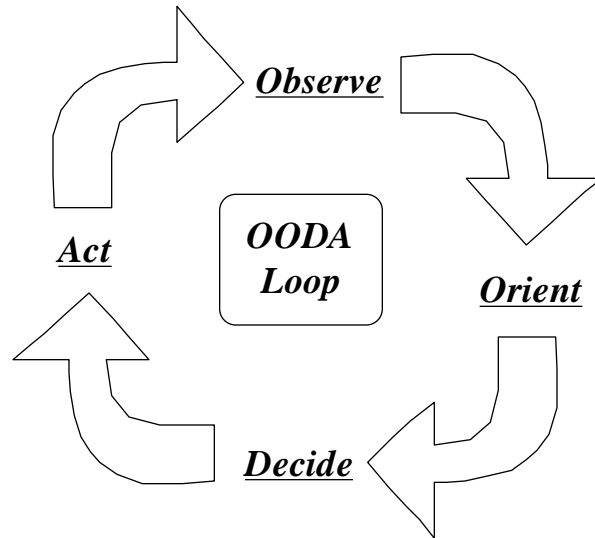
## Introduction

There has been a lot of discussion about *what* is needed in a data fusion system. This paper answers the question of *how* by presenting an architecture for an information control system that can probably be fully operational by 2025.

## The Problem

A military command and control system should provide the commander with a clear understanding of the developing operation so that forces can be directed in a manner to meet a specified objective. Such a system surveys the battlespace, assesses what actions to take, and uses available resources to implement those actions. Maintaining this order of battle involves managing and communicating information.

The current command and control system is basically an inventory function; keeping track of what assets go where and what the capabilities of each are all while maintaining communications among force levels. John Boyd's OODA Loop is a standard model for the decision-making process used in the current C<sup>4</sup>I system.<sup>1</sup> OODA stands for Observe, Orient, Decide, and Act, the parts of a four-step framework for command and control.



**Figure 1-1. OODA Loop - A Paradigm for Command and Control**

Unrestricted information flow up and down the chain of command has always been essential, as is apparent in the 1939 writings of Maj Gen J. F. C. Fuller.

If intercommunications between events in front and ideas behind are not maintained, then two battles will be fought—a mythical headquarters battle and an actual front line one, in which case the real enemy is to be found in our own headquarters. Whatever doubt exists as regards the lessons of the first war, this is one which cannot be controverted.<sup>2</sup>

Even today the system is characterized as slow, incomplete, and unresponsive. Evidence of this is apparent as recently as Operation Desert Storm, where there were examples of a communications breakdown between intelligence gathering and command and control. For example, target information collected from United States intelligence systems had to be delivered to the theater by way of secure telephone.<sup>3</sup>

Many familiar with command, control, communications, computers, and intelligence (C<sup>4</sup>I) procedures and capabilities view the current system as limited, unresponsive, and improperly utilized. During peacetime operations, data is poorly distributed and processed. Commanders are often forced to make decisions without access to all



available data. The system is inefficient and often results in long delays in transferring vital data. During conflict, this problem is compounded because of limited communications at deployed locations and the confusion inherent in any mobility effort. C<sup>4</sup>I channels become flooded because of the large number of sorties and special requirements for each type of weapon system. Airborne sorties in a rapidly changing environment are sometimes effectively cut off from their commanders.

Due to the present tempo of operations, a major frustration in the current C<sup>4</sup>I arena is the knowledge that whatever information required is available but not accessible. Commanders cannot make well-informed decisions because they do not have the most current data from all possible sources. Present data networks do not allow for information to flow between all sources in a systematic and user-friendly manner. Commanders need to be able to assess any aspect of a situation they desire in a timely manner without being overloaded with extraneous data. Current C<sup>4</sup>I systems such as the Worldwide Military Command and Control System (WWMCCS) provide decision makers with data. Commanders need to see this data after it has been processed into a logical, simple, recognizable, and complete format. Information may be defined as data that has been collected, systematically processed, and put into a format that is easily understood by the user. This process is known as *data fusion*.

The current system allows commanders to utilize only a fraction of the potential information sources. This problem exists because these systems exist as separate entities rather than as a cohesive network. The individual systems are poorly integrated and separately tasked, and their output supports separate user bases<sup>4</sup>.

Recent improvements to the current C<sup>4</sup>I system have expanded the type, quality, and distribution of information. At the same time, there have been dramatic advances in the speed and lethality of weapon systems. As a result, the decision maker is now forced to assimilate and act upon information in an even shorter time.

### **A Revolutionary Solution**

As we have learned from experience, “Nearly always it is the evolutionary follow-on of a new concept that produces a revolutionary capability.<sup>5</sup>” In 2025, weapon systems will have advanced to the point where even today’s third world countries may be capable of launching theater-range ballistic missiles and detecting aircraft that utilize current stealth technology. Access to space will be available to any country that can pay for it. Most countries will be on the same technological level in the war-fighting arena. With the technological edge diminished, the US must focus on developing ways to best gather and distribute vital information; on a global scale, in near real time.

The United States armed forces must develop a global information control system capable of automatically gathering data, processing it, and presenting the resulting information to the user in a concise manner. This system, the Worldwide Information Control System (WICS), would provide a means for global data collection, intelligent processing, and instant global communications with enough flexibility for both peacetime and contingency operations. The concepts of data fusion and a global information network may not be new, but the methods of implementing them are.

The key to implementation in the year 2025 will be to transform the current paradigm of Boyd’s OODA Loop. Command and control in 2025 must go beyond the limitations of

the OODA Loop. The time available to make critical decisions will be drastically reduced in the future. Fractions of a second will be critical in all aspects of a military campaign—not just the “fighter pilot scenario.” Because of this, the four-step OODA Loop must be refined into a more timely and automated process. A natural progression of the OODA Loop and the drive for in-time command and control information will require the military of the future to react faster than an opponent can operate its decision-making process.<sup>6</sup>

This was also discussed in “The Man in the Chair,” an Air Force 2025 white paper which describes how the OODA Loop has continuously shrunk throughout the history of warfare and will continue to shrink.<sup>7</sup> In the future, the OODA Loop will be transformed into a format where its four components will seem to occur simultaneously. Inherent speed and accuracy limitations in human information processing abilities point to the need for automation by a data fusion system that is capable of making decisions based on a global, cohesive information infrastructure. A human interface must remain in the loop to have a final “vote” in the decision process. However, a “smart” architecture will be essential to collect, filter, and disseminate the pertinent information in time for the war fighter to make well-informed decisions in a timely manner.

Such a system must continually perform the future equivalent to today’s “observe” and “orient” processes. When tasked, it should also be capable of expediting the “act” phase of the OODA Loop by providing in-time communications to commanders and war fighters. To the future war fighter, today’s OODA Loop will be reduced to decision making based on a condensed global representation of all pertinent information.

Current upgrades and improvements to the C<sup>4</sup>I process are steps in the right direction but are evolutionary in nature and represent only a fraction of the capabilities of the

system that will be needed by 2025. What is really needed is a revolutionary system that can assemble, maintain, and distribute information in time for the warfighter to make effective decisions.

The word “revolutionary” is often used when describing new or future war-fighting systems, but what does it really mean to be “revolutionary”? *Webster’s New World Dictionary* defines revolutionary as “bringing about or constituting a great or radical change.” When viewed in this light, few systems actually deserve to be called “revolutionary.” Among these are the tank, the submarine, the airplane, the satellite, and perhaps a handful of others. Systems such as the global positioning system (GPS), while often spoken of as being revolutionary, are actually, upon closer inspection, evolutionary systems. For example, GPS evolved from the US Navy’s Transit positioning satellite system, which itself is an evolution from shore-based radio navigation systems and techniques. What is revolutionary about GPS is the *capability* it unlocked. WICS itself may be considered an evolution of current C<sup>4</sup>I efforts, but by providing the “God’s eye view” commanders have always longed for, it would bring about a revolution in the manner in which forces are managed.

## Notes

<sup>1</sup> Jeffery Barnett, *Future War: An Assessment of Aerospace Campaigns in 2010* (Maxwell AFB, Ala.: Air University Press, 1996), 6–7.

<sup>2</sup> J. F. C. Fuller, *Infantry in Battle*, 1939, as quoted in Peter G. Tsouras, *Warrior’s Words: A Quotation Book* (London: Arms and Armour Press, 1992), 94.

<sup>3</sup> D. A. Fulghum, “Glosson: U.S. Gulf War Shortfalls Linger,” *Aviation Week & Space Technology*, 29 January 96, 58.

<sup>4</sup> Barnett, 109.

## Notes

<sup>5</sup> USAF Scientific Advisory Board, *New World Vistas: Air and Space Power for the 21<sup>st</sup> Century*, summary volume (Washington, D.C.: USAF Scientific Advisory Board, 15 December 1995), 13.

<sup>6</sup> Barnett, 6–7.

<sup>7</sup> Clarence E. Carter, et al., “The Man In The Chair: Cornerstone of Global Battlespace Dominance,” Air Force 2025 draft white paper, 11 March 1996.

## Chapter 2

### Information Control in 2025

*We must remember that science and science fiction are related only superficially.*

—Air Force Scientific Advisory Board, *New World Vistas*

It is very difficult to accurately predict the operational environment of 2025. The technological advantage that US weapon systems have enjoyed is decreasing due to the proliferation of technologies to the commercial sector and to other nations. Former or potential adversaries are gaining access to space and ballistic missile technologies, and they are starting to use information systems like the Global Positioning System (GPS) and commercial remote-sensing surveillance systems such as the French system probatoire d'observation de la terre (SPOT). Because information is essential to fighting wars, the upper hand in future conflict may belong to the nation that does the best job utilizing and controlling the information flow.

Due to the unpredictability of the future environment, it is very difficult to determine what tools must be developed to meet information control requirements. Instead, it is more important at this stage to develop an architecture that is able to operate effectively in a number of technological scenarios. This will allow changes in the geopolitical

environment, technological advances, and operational needs to dictate the specific tools that will be developed in the next 30 years.

### **Required Capabilities**

The key system drivers for a military information control system would most likely be the demands for coverage, mobility, timeliness and security. Figure 2-1 summarizes the mission need statement for a comprehensive global information control system. Mission objectives and top-level mission requirements are then derived from the mission statement using an established systematic design approach as described by Larson and Wertz.<sup>1</sup> The mission objectives are presented in figure 2-2.

<b>Mission Need Statement</b>
<p>Putting timely and accurate information in the right hands can be a tremendous advantage during war. The United States needs to develop a system to globally collect, process, and present useful information from multiple sources to the war fighter in near real time. This system should also allow for secure worldwide communications. The information products must meet the unique timeliness, mobility, and security requirements of military users at all levels, including the individual.</p>

**Figure 2-1. WICS Mission Statement**

<b>Mission Objectives</b>
<b>Primary Objective:</b>
Gather, process, and present “in-time” information to military users
<b>Secondary Objective:</b>
Provide uninterrupted, secure, global communications for military forces

**Figure 2-2. WICS Mission Objectives**

Top-level mission requirements for WICS can be derived from the mission objectives.<sup>2</sup> Functional requirements define how well the system must perform to meet its objectives; operational requirements describe how the system operates and how users interact with it to achieve its broad objectives. Constraints are limitations imposed by shortfalls in a system architecture or an outside agency. These requirements will drive the system design.



**Table 1**

**WICS Top-Level Mission Requirements**

<b>WICS Top Level Mission Requirements</b>	
<b><u>Functional</u></b>	
Performance	Optimized resolution, high bit rates
Coverage	Global coverage, near continuous coverage, mobile targets will require wide area searches
Responsiveness	High percentage of users connected with “in time” updates
<b><u>Operational</u></b>	
Availability	100 % available
Survivability	Natural and man-made threats
Data Distribution	Mobile, wireless access from anywhere on globe
Data Content, Form, and Format	Information tailored to individual user
<b><u>Constraints</u></b>	
Cost	Must be affordable
Schedule	Fielded and operational by 2025
Regulations	International frequency allocations?
Interfaces	Must function with existing (in 2025) systems

Due to the vast quantity of data that will be available from many sources, commanders and war fighters will need a system capable of collecting, processing, and presenting useful information in a timely manner and of providing secure global communications. Information must be presented to a user located anywhere on the globe in time to make meaningful decisions. Advances in information collection and

transmission technologies are progressing rapidly. Properly utilizing information will give forces a tremendous advantage in future conflicts. Failure to develop an information control system that includes necessary processing will likely result in information overload, where individuals will not be able to decipher pertinent information from extraneous data and it will become impossible to make rapid, well-informed decisions.

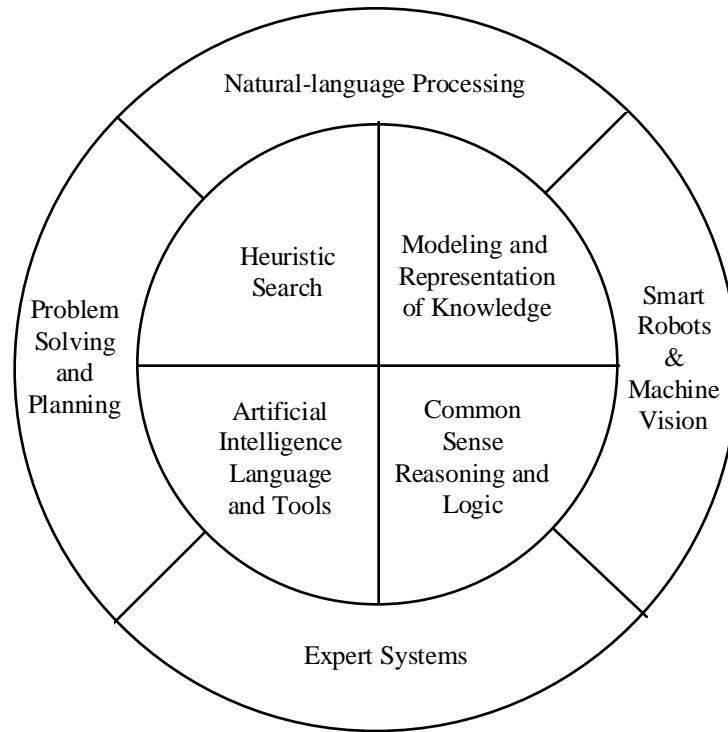
### **Data Collection and Processing Requirements**

Data is currently acquired through many separate sources. Each source operates independently, and in-time access to worldwide, complete C<sup>4</sup>I information is not available. There is not a comprehensive system to collect, process, and present the information. For an advanced system to be properly fielded, each individual collection source must be capable of sending information back and forth. This will require future data collection systems to include a common communications package.

Additionally, a comprehensive information control system must be capable of processing data from many different collection points simultaneously. This parallel processing will occur using data from conventional sources such as airborne platforms and space-based imagery, as well as advanced technologies that will be available by 2025. These follow-on systems must be designed to interface with the new information control system.

## **Artificial Intelligence Requirements**

To process data in near real time, it will be necessary to field a system with artificial intelligence (AI) capabilities. Figure 2-3 shows the basic elements of AI (located on the wheel hub) and the corresponding applications (located on the wheel rim). AI is a challenge that must be overcome by a future information control system, especially when considering AI's relatively slow progress in the past 30 years. Machine vision applications could be used to automatically interpret and analyze images (e.g., automatically detecting and identifying potential targets). Problem-solving applications could be used to process multiple source redundancies by passing them through a "data divergence" filter. Conflicting data will be transformed into information, assuring confidence without redundancy. In addition, data from different sources must be compared as a validity cross-check before the redundant data is removed from the information flow. If there is a discrepancy in acquired data, the system must be capable of realizing this and either comparing the data with additional sources or judging the confidence level of the sources to determine which is likely to be accurate. Expert systems applications should be used to prioritize information (i.e., determine what information is critical). And finally, natural-language processing should be used to enhance user-machine interfaces.



**Figure 2-3. Elements of Artificial Intelligence**

Once data is filtered, it must be automatically sorted by level of interest. All users of an intelligent information control system will not require the same fidelity of information. Clearly, theater commanders and troops in the field will have vastly different demands for the system. To work efficiently, a system of this type must be able to recognize the user and determine what level of fidelity is required. The system must be able to automatically adjust the data product to meet the needs of particular users. At the same time, the user must retain the ability to customize data requests. Giving the system the ability to sort data is vital if individuals at various levels are to avoid “information overload.”

The white paper “Information Operations: Wisdom Warfare for 2025” discusses the “models, simulations, software agents, predictive decision aids, planning and execution tools, and archival methods” that must be incorporated in a WICS architecture.<sup>3</sup> Methods such as Markov chains, the fuzzy cognitive map, and chaos

theory are on the leading edge of research in the data-processing arena. Advances in these fields must occur and will define the information processing algorithms for WICS.

### **Presentation Requirements**

After data has been collected and processed, it must be effectively presented to the user. This will likely be one of the most difficult technological aspects of the information control system. A challenge for future computer systems will be transferring the burden of interaction from the user to the computer<sup>4</sup>. Every user has unique requirements. As a result, it will be necessary to present information in many different ways. At the highest levels, national command authorities (NCA) must be able to access a database of worldwide information. The database should provide a virtual-reality representation of any geographic region of interest. Additionally, it must be suitable for in-time decision making and for war gaming a number of possible scenarios. Ideally, this should be coupled with war simulation capabilities to allow commanders to see the likely outcomes of their decisions, based on historical data, before they issue a tasking order.

The system for theater and battlefield commanders should essentially be a specialized subset of the capabilities at the NCA level. Information must be condensed to allow for adaptation to dynamic local conditions. The greatest benefit will be derived by using this information to create a virtual battlefield. The theater-level, data-collection system should allow joint task commanders to view a battlefield in near real-time with a high level of fidelity. By being able to visualize the compilation of immense quantities of information, commanders will be able to make well-informed, time-critical decisions.

A very different type of information presentation system will be required for the unit level C<sup>4</sup>I operations. The operational information control system must be capable of providing information on many different levels. For instance, a unit based in the continental United States may need to see a projected worldview to determine where airborne sorties are located on an overseas flight while simultaneously showing a virtual image of the local traffic pattern to another local user. The output device may not appear very different from the Global Command and Control System (GCCS) that is now being phased in. In fact, this epitomizes what should be a key goal in designing a new C<sup>4</sup>I system: The infrastructure of the system and its data-processing techniques must remain transparent to the user.

Additionally, units must have a user station that is portable and can be used reliably in a combat environment. The system must be capable of operating from many different platforms, including aircraft, ground assault vehicles, naval vessels, and the individual user. It must be durable, secure, lightweight, and simple to use. This will require additional data-processing and refinement techniques beyond those required at the NCA and theater levels. WICS must be able to tailor information at the receiver end to satisfy individual needs and preferences.

### **Communications Requirements**

Data collection, processing, and presentation do not constitute a complete information control system. The other component needed is communications. An effective future information control system must give military users the ability to receive and transmit vital information anytime and anywhere. Regardless of the method, the

system must satisfy obvious needs for global, mobile, secure, and redundant coverage must be satisfied. Without a comprehensive, reliable communications system, the rest of the information control network will be useless.

### Notes

<sup>1</sup> W. J. Larson, and J. R. Wertz, *Space Mission Analysis and Design*, 2d ed. (Microcosm, 1992), 12.

<sup>2</sup> Larson, 14.

<sup>3</sup> “Information Operations: Wisdom Warfare for 2025,” Air Force 2025 draft white paper, 11 March 1996.

<sup>4</sup> Nicholas Negroponte, *Being Digital*, (New York: Vantage Books, 1995), 92.

## Chapter 3

### System Description

The best way to describe WICS is to separate the system into its functional components. There are four basic components to WICS: *Data Collection*, *Data Processing*, *Information Presentation*, and *Communications*. Data collection involves all activities where data is collected. Processing is the element of the system that transforms data into useful and recognizable information. Information presentation involves the military user's ability to access information; it is the interface between the processed information and the user. The communications element involves all chain-of-command communications, the transmission of information from the system to the user, and feedback from the user to the system.

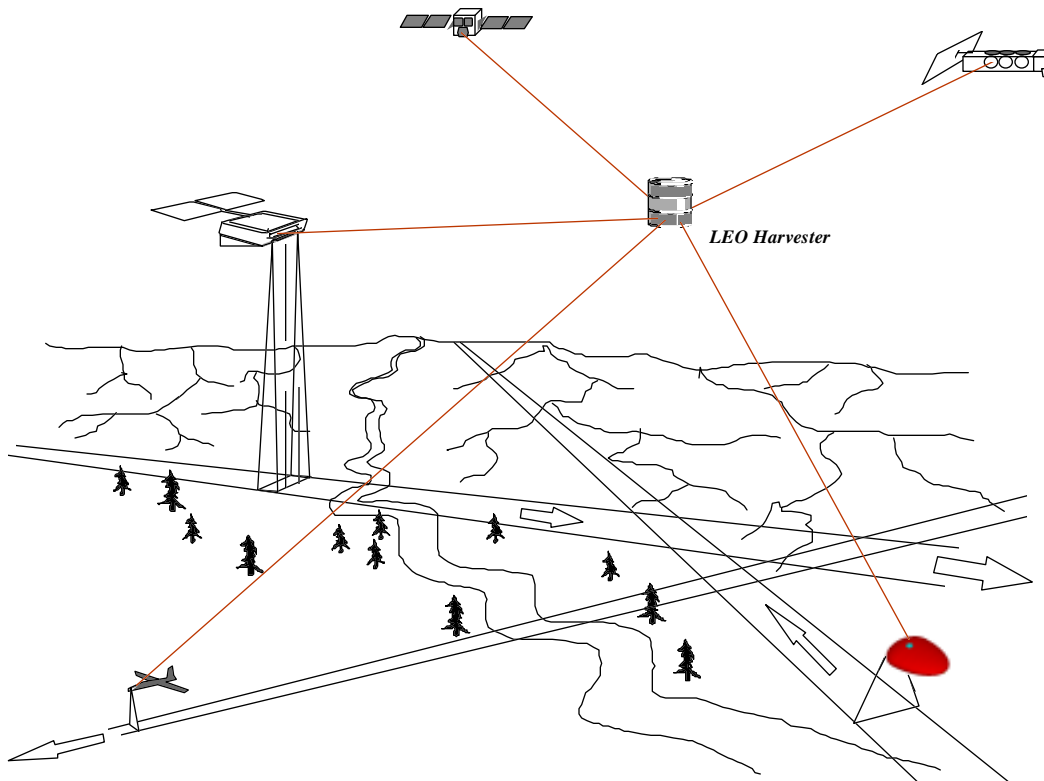
#### Data Collection

The timely access and global coverage advantages of space-based platforms will be particularly important in satisfying the demand for “in-time” information. WICS will use a constellation of low earth orbit (LEO) satellites, called *LEO Harvesters*, to gather and preprocess the data from a number of existing (in 2025) space- and ground-based data-collection sources. The sensors themselves could be commercially developed and



operated as predicted by *New World Vistas*,<sup>1</sup> or they could be owned and operated by the government. In 2025, data-collection systems will most likely be some combination of military and commercial.

The individual data-collection systems will be operated and controlled independently of WICS but they will be “plugged into” WICS by dumping the data they collect to the LEO Harvesters. It is anticipated that in 2025 these individual systems will include the general categories of weather, navigation, surveillance, and reconnaissance. Additionally a “self awareness” system could be implemented that would function as a space-based military traffic and logistics control system and would keep track of all friendly systems. An “enemy tracking” system could keep track of enemy assets, activities, and maneuvers.<sup>2</sup> The basic concept of WICS data collection is summarized in figure 3-1.



**Figure 3-1. WICS Data Collection**

The LEO Harvesters will receive periodic data updates from the individual collection systems via secure laser communications links. A laser communications system will be used because of its potential for increased bandwidth and security.<sup>3</sup> Lasers can offer increased data rates on the order of billions of bits per second. The increased security is a consequence of the smaller beam divergence angles, which make the signal more difficult to intercept.<sup>4</sup> Also, communicating at optical frequencies will inherently involve smaller components.<sup>5</sup> For transatmospheric links, one of several infrared (IR) wavelength bands can be chosen that fall within “spectral windows” that have a reasonably high atmospheric transmissivity (see table 2). Spectral windows also exist at other wavelengths. Visible bands (0.4-0.7  $\mu\text{m}$ ) will be avoided to maintain options for covert operations. Low-frequency signals should be avoided because they correspond to lower energy levels, resulting in an increase in atmospheric attenuation.

**Table 2**

**Infrared Spectral Windows**

Window	Percentage Transmission
1.1 - 1.2 $\mu\text{m}$	84
1.2 - 1.3 $\mu\text{m}$	80
1.5 - 1.8 $\mu\text{m}$	77
2.0 - 2.4 $\mu\text{m}$	80
3.5 - 4.0 $\mu\text{m}$	85
4.6 - 4.9 $\mu\text{m}$	40
8.0 - 13.0 $\mu\text{m}$	72

The type, quality, and quantity of data collected will depend on the capabilities of the individual collection systems. It is also possible that data-collection systems that exist today as independent systems could be combined in 2025 to form a multimission sensor (e.g., weather and reconnaissance combined). Regardless of what the individual

collection systems look like, they will need to be only modified slightly to be compatible with WICS. They will each need to be equipped with a laser transceiver system, and each must be programmed to periodically “dump” their data to the LEO Harvesters via the laser link. When new collection systems come on line they can easily be “plugged into” WICS.

Remote-sensing satellites will not be the only means of acquiring information. Other data-collection sources will include standard intelligence operations (e.g., human intelligence, communications intelligence, etc.), unmanned aerospace vehicles (UAV) and remotely piloted vehicles (RPV), unattended ground sensors (UGS), sensors on weapon systems, and possibly other systems, depending on what is available in 2025. A summary of possible 2025 data-collection systems is given in table 3. Data collected from terrestrial systems may be periodically uplinked to the LEO Harvesters via a laser communications link.

**Table 3**  
**2025 Data Collection Systems**

SYSTEM	DESCRIPTION
Weather Satellites	Terrestrial and space weather
Navigation Satellites	Near-real-time-accurate position information on all military craft and weapons (bombs, etc.)
Surveillance/Reconnaissance Satellites	Intelligence collection
Self-Awareness System	Space based system that provides craft information (location, fuel, ordinance, health, maintenance records, etc.) and crew information (casualties, supplies, morale, etc.)
Enemy Tracking System	Enemy ship, aircraft, and troop movement, launch detection, target identification.
Terrestrial Data Collection	UAV, RPV, intelligence operations, UGS

## Data Processing

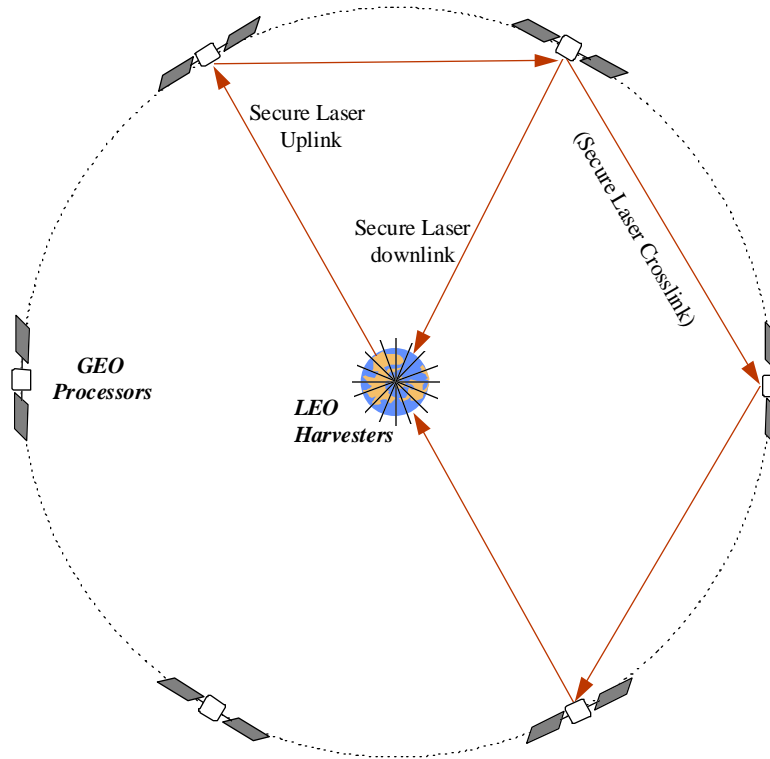
On-orbit data processing is needed to quickly reduce, analyze, and format the vast amount of data that will be collected and to transform it into information that can be distributed and used. Processing data on-orbit will save much-needed time. Given sufficient technological advances (see chap. 5), ground-based processing, storage, and analysis will not be needed in 2025. Satellites today are used in a “bent-pipe” fashion in which data is collected and transmitted to ground stations for processing. This takes time. In 2025 this bent-pipe paradigm will be eliminated and processing will be done on board the satellites for faster delivery to the user. Basically the processors used by WICS will transform all of the collected data into information, the distinction being that information is the usable subset of the data (fig. 3-2).



**Figure 3-2. WICS Processing - “Data in and Information Out”**

WICS has two options for the processing: geosynchronous orbit (GEO) processing or low earth orbit (LEO) processing. GEO processing will occur in the following manner. After the LEO Harvesters gather and preprocess the data from the individual collection systems, they will uplink the data via a secure laser communications link to one of a number of GEO processing satellites, called *GEO Processors* (fig. 3-3). The GEO

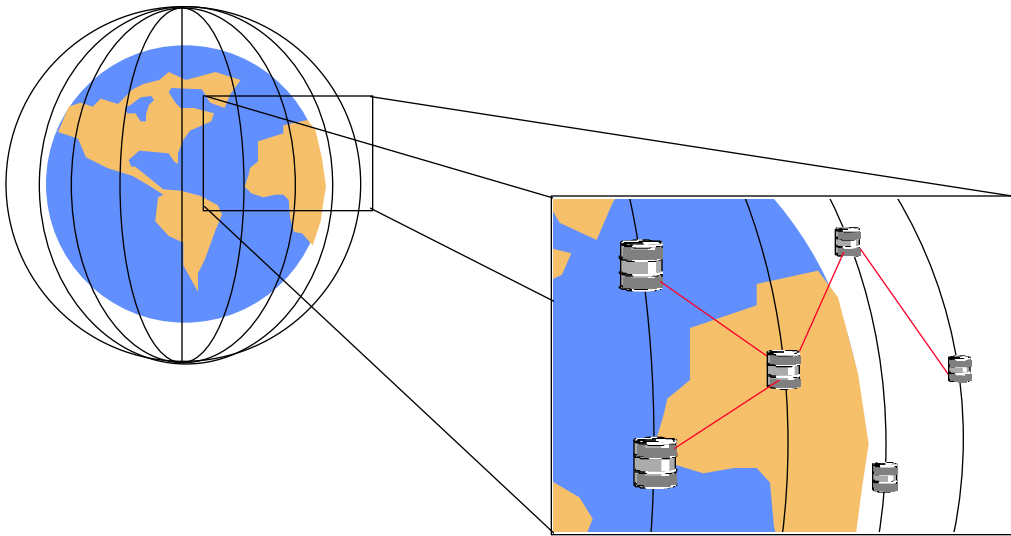
processors will have massive computing capabilities, and their positions in GEO will give global coverage with only a small constellation of satellites.



**Figure 3-3. GEO Centralized Processing Alternative**

With sufficient advances in distributed processing technology, the LEO Harvesters could be used in a networked fashion to process the data and transmit the information product to the user base. To maintain coverage, many more satellites will be required for LEO-based distributed processing. This alternative is demonstrated in figure 3-4. One disadvantage of processing at GEO is the introduction of about a quarter second time lag for the signal to travel there and back. Regardless of the location of the processing, software updates to space-based processing satellites can be made easily, but it will be more difficult to replace hardware as it fails or becomes outdated. A cheaper and more

responsive satellite development and launch system, therefore, will be necessary to provide the ability to easily and cheaply field and replace satellite systems as the hardware fails or becomes outdated. A summary of some of the trades associated with processing at LEO or at GEO is provided in table 4. The direction chosen will largely depend on the state of the art in processing technologies and also on the responsiveness and economy of spacelift capabilities in 2025 (i.e., our ability to field, support, and replace space systems).



**Figure 3-4. LEO-Distributed Processing Alternative**

**Table 4**

**LEO-Based versus GEO-Based, On-Orbit Processing**

<b>LEO Distributed Processing</b>	<b>GEO Centralized Processing</b>
<u>Advantages</u> <ul style="list-style-type: none"> <li>• Shorter transmission time</li> <li>• Negligible range loss</li> <li>• Easier to replace hardware as it becomes outdated</li> <li>• Faster processing</li> <li>• Greater processing capacity</li> <li>• Large network provides system robustness</li> </ul>	<u>Advantages</u> <ul style="list-style-type: none"> <li>• Fewer satellites needed for coverage</li> <li>• Easier to control</li> <li>• Easier to integrate data<sup>6</sup></li> </ul>
<u>Disadvantages</u> <ul style="list-style-type: none"> <li>• More satellites needed for coverage</li> <li>• Complicated cross linking</li> <li>• Larger, more complicated LEO Harvester</li> </ul>	<u>Disadvantages</u> <ul style="list-style-type: none"> <li>• 1/4-second time lag</li> <li>• Larger transmission losses (1/Range)</li> <li>• Need more powerful transmitters</li> </ul>

Artificial intelligence (AI) will be used by the processing satellites to decipher duplicate or erroneous information; it will also act as a smart switchboard to determine and relay critical information to critical assets and to ground centers for further processing. AI will be used to create and prioritize information structures from the synthesized data. This will give WICS the ability to automatically determine what is critical and “tap” the user on the shoulder when there is trouble. An example of critical information would be updates on the positions and velocities of enemy aircraft or ballistic missiles. This information would be downlinked to the appropriate defensive systems.

A challenge for WICS will be to process the data from each individual system while keeping track of the separate applications and user requirements. Processing is very application dependent. Surveillance systems, for example, will require image processing to automatically detect and track potential targets. Here, a spectral “directed vision”

concept could be used that would combine a low-resolution rapid area search to detect targets and a higher-resolution secondary system to interrogate reported target locations.<sup>7</sup>

In addition to the processing done on-orbit, more in-depth human analyses may also be required. For this reason the data from the processing satellites will be downlinked periodically, or upon request, to ground-based processing centers for further analysis. Also, the system will be flexible enough so that the format of the processed data can be easily modified to meet changing user requirements.

The next step is to get the information from the processors to the users. There are two ways that WICS can make this happen. The first is a direct link from the processing satellites (either LEO or GEO) to critical assets to update critical data as it becomes available. The second way the information will be presented to the user is through the battlenet, a streamlined, computer-based, networked information data base similar in concept to the internet. Battlenet will manifest itself in different forms depending on the type of user. All users will have free and open access to the information. Information deemed critical will be updated automatically. Other information can be accessed on a self-serve basis.

### **Information Presentation**

Different types of users will have different kinds of information and mobility demands. The main user classes will be the NCA, theater commanders, battlefield commanders, and the troops. A common attribute of popular information systems is that user appetite often exceeds the system capacity. The result is often an overburdened, unresponsive, and clogged system. To avoid this problem battlenet users will access the



system through one of many distributed “mirroring sites.” These sites will be located at the battlefield level. Because they would be maintained in a distributed manner, there would be less demand on a single transmission path, thus minimizing bottlenecks. Stationary sites can be connected by fiber optics, which can provide extremely high bandwidth. Mobile platforms and individuals can tap into the WICS communications network that will act as an “internet in the sky.”<sup>8</sup>

At the NCA level the information flowing into the battlenet will be part of a larger war room environment. Battlenet information will support a number of activities including strategy development, battle management, keeping track of foreign and enemy capabilities, getting the latest in strategic intelligence updates, offering the means for secure worldwide communications. The battlenet will also give the NCA the ability to conduct high-fidelity war simulations and the capability to watch the war as it happens using a combination of real and virtual data.

At the theater commander level, battlenet will be an integral part of command center operations. Here, theater and battlefield commanders will use its information resources to select targets, conduct near-real-time battle damage assessment, track enemy maneuvers, and keep tabs on the weather. A virtual battlespace will be automatically updated to let commanders “watch” the conflict, make decisions, and implement them as necessary. Data collected and processed by WICS will be used to update terrain maps, targets, and structures in the virtual battlespace.

At the troop level the battlenet will be implemented as the personal interface card (PIC), a do-it-all credit-card-sized computer similar to the “wallet PC” envisioned by Bill Gates.<sup>9</sup> It can also be plugged into a weapon system, much like an automated teller

machine (ATM) card, effectively making the weapon system an extension of the user, which will customize the weapon system to meet the individual user's needs and capabilities. PIC will update airmen, sailors, soldiers, and marines on their positions, update their weapon systems on the locations of targets, locations of service support (e.g., close air support), and provide a communications link. The layered information access requirements are summarized in table 5.

**Table 5**  
**User Information Requirements**

NCA	Theater CC/ Battlefield CC	Troop
<ul style="list-style-type: none"> <li>• Strategy</li> <li>• Battle Management</li>   <li>• Enemy/Foreign Capabilities</li> <li>• Intelligence Information</li>   <li>• Secure Communications</li> <li>• Virtual Battlefield (Simulation)</li> </ul>	<ul style="list-style-type: none"> <li>• Target Selection</li> <li>• Battle Damage Assessment</li> <li>• Enemy Tracking</li>   <li>• Weather</li>   <li>• Imagery</li> <li>• Near-Real-Time Battle Plan Updates</li> <li>• Virtual Battlefield (Simulation/Training)</li> <li>• Secure Communications</li> </ul>	<ul style="list-style-type: none"> <li>• Navigation</li> <li>• Situational Awareness</li>   <li>• Targeting</li>   <li>• Troop/Craft Management</li> <li>• Enemy Tracking</li> <li>• Secure Communications</li> </ul>

PIC will add to the tailoring WICS gives to different user classes by acting as an *interface agent*. A concept described by Nicholas Negroponte, interface agents are located at the receiving-end computing platform and will have the ability to recognize and present the data product in a manner that is most effective for a particular user.<sup>10</sup> The user and interface agent will have a symbiotic relationship that will build with each new shared experience. The use of interface agents is different from today's paradigm. The

situation today is characterized by “dumb” computing systems that do not recognize or understand the needs of a particular user. In 2025 computers will know you much better. The agents will remember a user’s specific needs and recall how those needs change under different circumstances.

### **Communications**

WICS will handle data/information and voice communications differently. As previously mentioned, the transfer of information between collection systems and the LEO Harvester satellites, between satellites, and from satellites to the mobile users will be done through secure laser communications links. Voice communications up and down the chain of command will be handled through the use of commercial telecommunications satellites. There are many LEO communications systems currently being developed that should be operational by 2010. By 2025 these systems should be fielding their “block II” systems. Also, negotiations are under way today to equip these space-based networks with capabilities for laser communications.<sup>11</sup> The Defense Department could negotiate to have secure military communications compartments on board. Near-real-time, two-way secure communications are needed at each user layer to communicate up and down the chain of command.

The idea of incorporating a commercially owned and operated communications satellite system into a military architecture raises the problem of the satellite system’s becoming a potential target for an enemy antisatellite (ASAT) weapon. The “blackhull versus grayhull” problem, as it is commonly called, is neither new nor unique to space systems. There is a real possibility that the owner of a commercial or civil “grayhulled”

satellite system, fearing its destruction, would not allow it to be turned into a “blackhulled”, -- thus targetable--military asset by placing a military payload onboard. WICS could avoid the problem by employing a dedicated system, identical to the commercial system but owned and operated by the military. Not having to share the system with the commercial/civil community has obvious advantages in terms of available capacity and communications security. The drawback to a government-owned communications satellite system is that the military would incur system operations and maintenance expenses rather than merely paying for the development of a military payload and a “user fee.” Another option is to take the opposite approach. The military could utilize the commercial system “as is,” without relying on separate satellites or specialized payloads. This approach--the “hide in the weeds” option assumes the level of secure communications a commercial company would require is good enough to satisfy military requirements. While this is probably the least expensive option, the problem arises of maintaining the integrity of a secure network used concurrently by nongovernment entities. In addition, if knowledge of military use of the system reached an ASAT-capable enemy, it may become a target regardless of whether the system is wholly, partially, or not at all owned by the government.<sup>12</sup>

Table 6 provides a summary of the revolutionary capabilities that the Worldwide Information Control System provides in contrast to the evolutionary path currently being pursued.

**Table 6**

**WICS System Summary**

<b>C4I Evolutionary Path</b>	<b>WICS Revolutionary Path</b>
<p><b>Collection</b></p> <ul style="list-style-type: none"> <li>• Improved individual systems</li> <li>• Multispectral imaging</li> <li>• Improved spatial resolution</li> </ul> <p><b>Processing</b></p> <ul style="list-style-type: none"> <li>• Terrestrial centralized processing</li> <li>• Human filter</li> <li>• Smaller computers</li> </ul> <p><b>Presentation</b></p> <ul style="list-style-type: none"> <li>• Dumb receiver</li> <li>• User friendly</li> </ul> <p><b>Communications</b></p> <ul style="list-style-type: none"> <li>• Less than 10 Gigabits per second</li> <li>• Radio Frequency communications</li> </ul> <p><b>Operations</b></p> <ul style="list-style-type: none"> <li>• Joint force operations</li> <li>• Condensed OODA loop</li> </ul>	<p><b>Collection</b></p> <ul style="list-style-type: none"> <li>• Harvest data from existing (in 2025) systems</li> <li>• Hyperspectral imaging</li> <li>• Spatial and spectral resolution</li> </ul> <p><b>Processing</b></p> <ul style="list-style-type: none"> <li>• On-orbit distributed networked processing</li> <li>• Directed-vision target detection and ID</li> <li>• Credit-card-sized computer (PIC)</li> </ul> <p><b>Presentation</b></p> <ul style="list-style-type: none"> <li>• Interface agents</li> <li>• User-computer symbiosis</li> </ul> <p><b>Communications</b></p> <ul style="list-style-type: none"> <li>• 40 Gigabits per second</li> <li>• Laser communications (data, images, video)</li> <li>• Commercial telecommunications (voice)</li> </ul> <p><b>Operations</b></p> <ul style="list-style-type: none"> <li>• Fully integrated operations</li> <li>• OODA point</li> </ul>

**Countermeasures**

Like every other major advance in military technology, from the flintlock musket to the supersonic fighter, opposing countries will tend to develop similar systems in parallel and also look for ways to exploit the weaknesses of their enemy’s systems. One possible countermeasure for WICS is an enemy ASAT that could take out satellites, ground segment, and/or satellite-to-ground links. ASAT tactics can take on many different forms, including active shoot/downs, jamming, communications interference, laser blinding of sensing platforms, and induced electromagnetic anomalies. ASATs are a concern because

WICS will depend heavily on the use of satellites for data collection and processing. The use of large constellations of microsatellites would diminish the effectiveness of any type of practical ASAT weapon. The large number of satellites would provide redundancy and replacements could quickly be launched (given a responsive launch system). A ground-based backup system for processing the data will allow the flow of information to continue if the processing satellites fail or are attacked. The information baseline provided by the battlenet will not be affected except in the frequency of its updates. The satellites themselves can be protected through signature-reduction techniques, maneuvers, and other options to make them difficult to find, and/or an active threat-mitigation system (e.g., a space-based laser follow-on to airborne laser). Link disruptions will be mitigated because of the small beam divergence angles inherent with laser communications. This will allow for pinpoint delivery of the message (uplink, downlink, or cross-link). Additional message interception mitigation techniques like frequency hopping could also be used. On-board processing, autonomous satellite operations, and distributed user terminals will reduce the need for a centralized (i.e., exposed) ground system.

Another countermeasure facing WICS is an adversary's use of the system to enhance its own war-fighting capabilities. Because the side that best controls information in 2025 will have a distinct advantage, an adversary may be more interested in using the system than in disabling it. Undeterred access to the data from a fully functional database may be far more valuable to an enemy than disabling the system. Information-control technologies must rapidly evolve with the system as an answer to this threat. The key will be to design a system that can easily be adapted to negate countermeasures. Employing denial tactics can introduce errors or completely deny use of the systems to all who

attempt to access the information without the proper access codes or keyed terminals. The use of laser communications will also help to prevent unwanted users from tapping into the system.

### Notes

<sup>1</sup> USAF Scientific Advisory Board, *New World Vistas: Air and Space Power for the 21<sup>st</sup> Century*, summary volume (Washington, D.C.: USAF Scientific Advisory Board, 15 December 1995), 10.

<sup>2</sup> Collectively these two systems will solve the friendly-fire problem. For example you could incorporate a system in a fighter that would (through the use of WICS) automatically be able to distinguish friendly assets from enemy assets and restrict fire mechanisms when a friendly asset is targeted.

<sup>3</sup> J. Frascinella, "Laser Bridge Across the World," *New Scientist*, 17 June 1995, 25.

<sup>4</sup> Morris Katzman, ed., *Laser Satellite Communications*, (Englewood Cliffs, N. Jersey: Prentice-Hall Inc., 1987).

<sup>5</sup> R. M. Gagliardi and S. Karp, *Optical Communications*, 2d ed. (New York: John Wiley & Sons, Inc., 1995), 3.

<sup>6</sup> *New World Vistas*, summary volume, 43.

<sup>7</sup> M. R. Whiteley, "Non-Imaging Infrared Spectral Target Detection", Air Force Institute of Technology, masters thesis, 1995.

<sup>8</sup> Carol Levin, "Competition Intensifies for Satellite Networks," *PC Magazine*, 12 March 1996. Available from <http://www.zdnet.com/pcmag/issues/1505/pcm00011.html>

<sup>9</sup> Bill Gates, *The Road Ahead*, (New York: Viking, 1995), 74.

<sup>10</sup> Nicholas Negroponte, *Being Digital*, (New York: Vantage Books, 1995), 150.

<sup>11</sup> Frascinella, 25.

<sup>12</sup> The "blackhull versus grayhull" problem was initially brought to the team's attention during the 2025 Advisors' briefing on 25 Mar 96.

## **Chapter 4**

### **Layered Access**

In its broadest sense, WICS will be employed as a three-tiered command, control, and communications system. Each fundamental tier is configured to the user level. At the top tier, the “strategic” level, the users will be the senior authorities based out of Washington, D.C. At the middle, the “operational” level, the users are the theater and battlefield commanders. At the lowest, the “tactical” level, the users are the smaller, division/ship/aircraft wing-sized units and their components. This in no way means the system is restricted to operating at specific levels of command. The strategic, operational, and tactical labels are used merely to describe, in the broadest sense, the type of information available. WICS will be, to the greatest extent possible, an open system, accessible to all legitimate users. Even if current titles and organizational structures such as “national command authorities,” “theater commander in chief,” and “joint force component commander” no longer exist in 2025, the fundamental strategic, operational, and tactical levels of command will continue to exist.

For purposes of system control, WICS can be divided into three components: the LEO Harvesters, the battlenet, and the communications system. The satellites that make up the constellation of LEO Harvesters will, for the most part, operate autonomously of



traditional, ground-based satellite command and control. This is not to say that satellite controllers will have no role in WICS operation. Rather, tasks such as station keeping, momentum dumps, and other routine tasks will be self-initiated. The LEO Harvesters will transmit periodic “state of health” reports, but will continuously monitor their own health and will be able to compensate automatically for common anomalies. WICS will alert ground controllers when unusual events occur; for instance, when a satellite is nearing the end of its life and needs to be replaced. If GEO processors are used to process the data, they will be controlled in a similar manner. The battlenet will be managed by a team of information management specialists. These individuals will not have direct control over what information is sent to whom. Their purpose will simply be to monitor and maintain the battlenet’s operational status and make changes as necessary. The third component of WICS, the communications system, will be controlled by its commercial owners, or if a military-adapted version is procured, in a manner similar to its commercial counterpart.

### **Tactical Layer**

At the tactical level, all personnel will carry a standard-issue personal interface computer (PIC). This device will link every soldier, sailor, airman, and marine, and give them access to a wealth of information via the battlenet. Through the PIC, all personnel will have access to basic information such as position, digitized maps, locations of nearby friendly and enemy forces, and the like. The PIC will also be a personal communications device, enabling individual troops to remain in contact with each other, their superiors, and their subordinates. In an emergency, the device could be used as a beacon to facilitate search and rescue operations. The PIC could be voice activated, use a miniature

alphanumeric keyboard, or both. The idea is “to put one in every soldier’s pocket, in every pilot’s flight vest.”<sup>1</sup>

In addition to the standard-issue PIC, commanders at the tactical level will be equipped with a larger and more capable version. These units can be carried by individuals or mounted inside command vehicles. This device would have all the capabilities of a standard PIC, but would allow commanders access to a greater variety of information, such as battle plans and logistics information. Commanders could request supplies, transmit unit status, report on the progress of operations, and so forth. By incorporating AI-based learning algorithms and common-sense reasoning and logic, WICS could automatically filter information gleaned from the battlenet and tailor it to suit the commander’s needs. For example, by knowing its precise location, the device would screen out troop movements that are not within a certain radius of its position. This avoids the commander’s having to wade through irrelevant information to get to what they really need. Of course, the commander would be able to query the battlenet for information not automatically provided.

In the air, WICS would be an integral part of the aircraft’s communication and navigation system. A transceiver mounted in the aircraft’s electronics will automatically and almost continuously transmit the aircraft’s coordinates to its controlling air operations center. WICS would also be wired into the aircraft’s health-monitoring systems. Data such as fuel stores, weapons stores, on-board cargo, and so forth, would be transmitted as well. Unmanned Aerospace Vehicles (UAV), both combatant and noncombatant versions, would be continuously and automatically fed navigation information, targeting data, and anything else they need to complete their mission. Simultaneously, WICS

would monitor the status of aircraft systems, automatically alerting ground facilities of the presence and nature of any trouble so a fix could be prepared in advance and implemented as soon as the aircraft lands. In the case of manned aircraft, WICS will prevent information overload by selectively filtering and reducing data to give the pilot exactly what he or she needs in terms of targeting data, nearby threat updates, weather conditions, and so forth. The pilot would have the capability to query WICS for any supplemental information. Vocal requests for information will be enabled through AI-driven natural-language processing. Just as important as a pilot's being able to query WICS vocally, WICS will be able to respond vocally, allowing the pilot's eyes and hands to remain focused on flying. Nicholas Negroponte predicts that, through speech storage and synthesis, machines with humanlike conversational capabilities will be in use.<sup>2</sup> As an example of a new capability enabled through WICS, *New World Vistas* noted future cargo aircraft should have "point-of-use delivery capability through precision airdrop as a routine process."<sup>3</sup> WICS will, through continuous and automatic position updates to both the airlifter and the intended target, enable this capability for both stationary and mobile drop targets.

### **Operational Layer**

At the operational level, in addition to having all the capabilities of tactical units, WICS will be able to conduct battle damage assessment, receive and process raw imagery from satellites and other collection sources, transmit and receive battle plan updates, and conduct near-real-time battle simulations (refer to table 5 for a listing of information requirements at each level). Commanders would be linked to WICS through the

battlenet, but also through direct satellite-to-ground laser downlinks. This provides a degree of redundancy, and allows the commander to directly task WICS to look for particular information that may be of unusually high value. WICS would operate in a “war room” setup at the theater/battlefield commander’s headquarters. Large cinema-like viewscreens would display the overall strategic view (i.e., the “God’s eye view”) in a virtual environment, providing all of the information necessary to give the commander, at a glance, an overall situational awareness. This includes, but is not limited to, enemy positions and strengths, the locations and status of friendly forces, and natural and man-made landmarks. Battlestaff personnel would be seated at consoles, each responsible for and continuously monitoring a particular functional area of responsibility (logistics, intelligence, etc.). Each staff officer would receive continuous updates, as well as have on-demand access to all information affecting the area of responsibility. By assigning one or more staff officers to a particular area of responsibility, information overload can be avoided. In addition to overall situational awareness, WICS would continuously conduct battlefield modeling and simulation exercises. One of the 2025 concept papers spoke of a system that would

not only consider current battlespace information, but would also have access to past historical information about the key political and military leaders involved and their decision-making histories and tendencies. In addition, the system would include information from key, successful political and military leaders. The system would be able to fuse this information and provide the commander or decision maker with possible outcome scenarios based on various actions the commander might take . . . and suggest alternate courses of action with their potential outcomes.<sup>4</sup>

WICS would perform this mission, acting as a knowledgeable advisor to the commander. Furthermore, information would not only be tailored to meet the commander’s needs but automatically presented in a format to his or her liking. In *Being*

*Digital*, Negroponte introduces the concept of a “digital butler,” a computer that possesses a body of knowledge about something and about the computer user in relation to that something (tastes, inclinations, etc.).<sup>5</sup> *New World Vistas* discusses a concept called “dynamic planning and execution control,” in which planning and operations tempos are increased and plans can be easily changed while maintaining consistency throughout the battlespace.<sup>6</sup> WICS would easily facilitate this. Overall, WICS would provide the theater commander with “dominant battlespace awareness,”<sup>7</sup> greatly reducing the decisionmaking and implementation timeline and increasing by leaps and bounds the efficiency in the way forces are employed.

### **Strategic Layer**

At the strategic level, WICS will be employed in a nearly identical manner to the operational level. The major difference would be that WICS will be a global system. WICS will be used to monitor events and control forces on a global scale. Global military and political events and strategies will be incorporated into the near-real-time planning, modeling and simulation, and execution processes. WICS will afford national authorities near-real-time situational awareness and control.

The flexibility of WICS to different situations can be illustrated by applying the system to the alternate futures envisioned in the 2025 study. Four of the alternate futures described are “Gulliver’s Travails,” “Zaibatsu,” “Digital Cacophony,” and “King Khan.”<sup>8</sup> In all four futures, but particularly in the “Gulliver’s Travails” and “Digital Cacophony,” knowledge of global events and near-real-time command and control of forces is critical.

In all four futures described, WICS provides global command and control, and situational awareness greatly enhances national security and capabilities.

### Notes

<sup>1</sup> 2025 Concept, no. 900585, “Global Location and Secure Comm,” 2025 Concepts Database (Maxwell AFB, Ala.: Air War College/2025, 1996).

<sup>2</sup> Nicholas Negroponte, *Being Digital*, (New York: Vantage Books, 1995), 144.

<sup>3</sup> USAF Scientific Advisory Board, *New World Vistas: Air and Space Power for the 21<sup>st</sup> Century*, summary volume (Washington, D.C.: USAF Scientific Advisory Board, 15 December 1995), 10.

<sup>4</sup> 2025 Concept, no. 900386, “Computer-Assisted Battle Decision System,” 2025 Concepts Database (Maxwell AFB, Ala.: Air War College/2025, 1996).

<sup>5</sup> Negroponte, 149–52.

<sup>6</sup> *New World Vistas*, summary volume, 26.

<sup>7</sup> B. R. Schneider and L. E. Grinter, *Battlefield of the Future: 21st Century Warfare Issues* (Maxwell AFB, Ala.: Air University Press, 1995), 91–94.

<sup>8</sup> “2025 Alternate Futures,” videotape of briefing to MAJCOM vice-commanders, January 1996.

## Chapter 5

### Enabling Technologies

*New World Vistas* identifies several primary technologies that will be required in 2025.<sup>1</sup> Those that are applicable to WICS are presented in table 7.

**Table 7**

#### *New World Vistas* Technologies Applicable to WICS

- High bandwidth laser communications for satellite and aircraft cross and downlink (\*)
- Distributed satellite vehicles and sensors
- Precision station keeping and signal processing for distributed satellite constellations
- Continuous simulation
- Secure operations across large networks having secure radio frequency components (\*)
- Information protection (\*)
- High speed processors
- Data compression systems
- Networking technologies
- Direct downlink broadcast equipment
- Fiber optic and satellite communication services

(\*) indicates technologies that will be pursued in both commercial and military forms

These and other key enabling technologies can be grouped into five areas. First, advances in *data-collection* technologies are needed so that we can collect data sufficient in quality and quantity. Second, advances in *data-processing* technologies are needed to handle that data. Third, advances in *presentation* technologies are required that will

dramatically improve the human-computer interface. Fourth, advances in *communications* technologies are needed to transmit large volumes of data “in-time” to multiple users simultaneously. Finally, *information-control* technologies must be advanced so data-gathering and communications activities can proceed undetected and uninterrupted.

### **Data-Collection Technologies**

Before we can collect enough data of the quality and fidelity required by WICS we need a big increase in satellite spatial coverage and a big decrease in satellite revisit times. Current satellite design concepts focus on developing highly-redundant systems with long design lifetimes. These vehicles are extremely expensive and generally require large, complicated boosters for launch. A better approach may be to develop the data-collection system around a large constellation of relatively simple, inexpensive, and expendable microsattellites. These microsattellites depend heavily on advancements in microminiaturization technologies. Each space-based individual collection system could include several dozen such satellites. Because they would be expendable by design replacements could easily be launched on a relatively cheap booster system. This also would provide operational flexibility because, given a more responsive spacelift capability, spare satellites and boosters could be prepared for short-notice launches to orbits providing additional coverage of specific geographic regions during conflict.

Data collected from all available sources, including weather, navigation, and imaging satellites, must become more refined. Improved resolution and target-identification



capabilities could be provided through spectral sensing rather than current spatial imaging techniques.

### **Data-Processing Technologies**

Improved data-processing capabilities could possibly be the key technological challenge facing WICS. Processing speed must continue to improve. Because of the immense quantities of data that will be processed by this system, it will be necessary to utilize artificial intelligence as part of the onboard processing system. Current satellites are “dumb systems” that do little more than serve as high-altitude transceivers. Instead, it is necessary to develop the next generation of “smart satellites.” These will use artificial-intelligence techniques to process and filter the data and prioritized information before it ever reaches the user. This will greatly reduce the user workload and, because extraneous data will be removed from the information flow, will improve the rate at which data may be transmitted. The filtered data will be transmitted to users at fidelity levels determined by the requirements of a particular user.

### **Data-Presentation Technologies**

The usefulness of the information will only be as good as the presentation format. This will require advances in software and smart user interface technologies, including virtual reality and interface agents.

## **Communications Technologies**

A major technical challenge that must be met to make WICS a reality is the improvement in communications technologies for voice, images, video, and data. Improved bit rates, data compression, and higher bandwidths are essential to this effort. Developments in laser communications are needed. Satellites must be standardized so that all of the space-based platforms are compatible and data cross-link can occur. Standard radio frequency signals are not practical for minimizing unfriendly access to data; their signals tend to spread over wide areas. One attractive alternative is the use of lasers to pass information. Lasers are attractive because of their higher data rates and smaller beam divergence angles. The use of laser communications will necessitate major improvements in pointing and tracking capabilities (systems will need to find and point to each other before they can transfer information). Also, methods are needed to mitigate the signal-degrading effects of atmospheric turbulence.

## **Information-Control Technologies**

In addition to improved pointing and tracking capabilities, several other steps must be taken to protect friendly access and deny unfriendly access to the system. Secure communications capabilities will be essential due to the sensitive nature of the information. Standard cryptographic and jamming techniques must be improved. Communications and access redundancy will be essential. As information warfare becomes more of a standard procedure, countermeasures must be developed and

employed in WICS. As a result, defensive counterinformation tactics must be developed to protect the system and restrict its access to unauthorized users.

### Notes

<sup>1</sup> USAF Scientific Advisory Board, *New World Vistas: Air and Space Power for the 21<sup>st</sup> Century*, summary volume (Washington, D.C.: USAF Scientific Advisory Board, 15 December 1995), 52–53.

## **Chapter 6**

### **Cost, Schedule, and Implications**

One of the prominent features of WICS that will reduce costs is that it will function with existing (in 2025) collection and communications systems. A partnership with the commercial space sector will give opportunities for cooperative relationships that have the potential to reduce costs. For example, a program similar to the Civil Reserve Aircraft Fleet (CRAF) can be used to augment military space capabilities, particularly in the area of communications satellites. Cost elements will include LEO Harvesters, interface costs associated with plugging the existing systems into WICS, data-processing hardware, communications infrastructure, and personal interface computers.

There is a high probability a system like WICS could be functioning in 30 years. The commercial sector is currently driving the market for advances in computing and communications technology because of the public's growing appetite for information access and mobile portable communications. Potential military applications cannot be ignored.

The layered implementation of WICS will serve several purposes and alleviate many concerns. First it will assure military campaigns are conducted under the principles of centralized control and decentralized execution. Second, it will maintain the

compartmentalization (i.e., need to know) character of the information security. Third, it will avoid information overload by presenting only necessary information in a recognizable and usable format.

Another possible concern is the reliance on space systems for military command and control. Space is a difficult and hazardous place to do business. Reliance on the LEO collectors and GEO processors raises several concerns. For example, what if they fail or what if the space environment interferes? Two things can be done to counter this concern. First, develop a backup system that can be utilized in the event of satellite failure. Basically, the data could be processed on the ground instead of on-orbit. This will reduce the timeliness of the data. Second, push for micro (throw-away) satellites and cost-effective, responsive space lift. If satellites fail or if they are attacked, they can be easily replaced with a responsive launch system.

## **Chapter 7**

### **Conclusion**

At first glance, the Worldwide Information Control System (WICS) appears to be “just another information system.” However, a closer look at WICS quickly discounts this notion because of the revolutionary capabilities it will bring to warfare. By 2025 technological proliferation will likely even the playing field to a level where only those who best control information will rise above their adversaries in war-fighting capabilities. If the necessary technological challenges are overcome, WICS can provide an adaptable architecture, leveraging 2025’s data collection systems and satisfying the information needs of war fighters. WICS will provide the essential framework to give the United States a revolutionary operational capability by 2025.

## *Bibliography*

- 2025 Concept. No. 900585, "Global Location and Secure Comm." 2025 Concepts Database. Maxwell AFB, Ala.: Air War College/2025, 1996.
- 2025 Concept. No. 900386, "Computer-Assisted Battle Decision System." 2025 Concepts Database. Maxwell AFB, Ala.: Air War College/2025, 1996.
- "2025 Alternate Futures," briefing to MAJCOM vice-commanders, January 1996.
- "The Air Control System." *Force Employment; Air Force Roles and Missions*. Maxwell AFB, Ala.: Squadron Officer School, March 1994.
- Barnett, Jeffrey. *Future War: An Assessment of Aerospace Campaigns in 2010*. Maxwell AFB, Ala.: Air University Press, 1996.
- Bowman, E.C. "Virtual Reality: Military Applications." Wright-Patterson AFB, Ohio: National Air Intelligence Center, Engineering Memo, TANB-EM-96-03, January 1996.
- Clapp, P. "Space Warfare C<sup>2</sup> Leaps Ahead Twenty Years." *Space Tactics Bulletin*, vol. 2, Issue 3, Summer 1995.
- Frascinella, J. "Laser Bridge Across the World." *New Scientist*, 17 June 1995.
- Fulghum, D.A. "Glosson: U.S. Gulf War Shortfalls Linger." *Aviation Week & Space Technology*, 29 January 1996.
- Gates, Bill. *The Road Ahead*. New York: Viking Penguin, 1995.
- Gertz, B. "The Air Force and Missile Defense." *Air Force Magazine*, February 1996.
- Hunt, V. D. *Artificial Intelligence & Expert Systems Sourcebook*. New York: Chapman & Hall, 1986.
- Katzman, Morris, ed. *Laser Satellite Communications*. Englewood Cliff, N. Jersey: Prentice-Hall Inc., 1987.
- "MIT Lincoln Laboratory Develops First Space-Qualified Laser for Coherent Satellite Communications." *Aviation Week & Space Technology*, 4 June 1990.
- Larson, W. J. and J. R. Wertz. *Space Mission Analysis and Design*, 2d ed. Torrance, Calif.: Microcosm, 1992.
- Morlan, Bruce. "Data Fusion." *Critical Technologies for National Defense*. Wright-Patterson AFB, Ohio: Air Force Institute of Technology, AIAA Education Series, 1991.
- Negroponete, N. *Being Digital*. New York: Vintage Books, 1995.

Schneider, B. R., and L. E. Grinter. *Battlefield of the Future: 21st Century Warfare Issues*. Maxwell AFB, Ala.: Air University Press, 1995.

USAF Scientific Advisory Board. *New World Vistas: Air and Space Power for the 21<sup>st</sup> Century*, Summary Volume. Washington, D.C.: USAF Scientific Advisory Board, 15 December 1995.

Whiteley, M.R. "Non-Imaging Infrared Spectral Target Detection." Air Force Institute of Technology, masters thesis, 1995.



# **2025 In-Time Information Integration System (I<sup>3</sup>S)**



A Research Paper  
Presented To

Air Force **2025**

by

Lt Col Robert L. Atkins, Jr.  
Lt Col Duane A. Lamb  
Ms Marlene L. Barger  
Maj Larry N. Adair  
Maj Michael J. Tiernan

April 1996

## **Disclaimer**

*2025* is a study designed to comply with a directive from the chief of staff of the Air Force to examine the concepts, capabilities, and technologies the United States will require to remain the dominant air and space force in the future. Presented on 17 June 1996, this report was produced in the Department of Defense school environment of academic freedom and in the interest of advancing concepts related to national defense. The views expressed in this report are those of the authors and do not reflect the official policy or position of the United States Air Force, Department of Defense, or the United States government.

This report contains fictional representations of future situations/scenarios. Any similarities to real people or events, other than those specifically cited, are unintentional and are for purposes of illustration only.

This publication has been reviewed by security and policy review authorities, is unclassified, and is cleared for public release.

## *Contents*

<i>Chapter</i>	<i>Page</i>
Disclaimer.....	ii
Illustrations .....	iv
Executive Summary.....	v
1 Introduction.....	1
2 The 2025 Challenge.....	7
Top-Sight Vision $\Rightarrow$ Information Dominance and Security.....	9
3 The In-Time Information Integration System (I <sup>3</sup> S).....	12
System Security .....	27
4 Concept of Operations.....	29
5 Enabling Technologies.....	36
Telecommunications.....	37
Computers.....	43
Sensors.....	48
6 Threats and Countermeasures .....	54
Security.....	55
Countermeasures .....	56
7 Conclusions/Recommendations.....	58
<i>Appendix</i>	<i>Page</i>
A Top-Sight Vision Model.....	62
Bibliography .....	63

## **Illustrations**

<i>Figure</i>	<i>Page</i>
3-1. Intelligent Microprocessor "The Brain" .....	13
3-2. Distributed Architecture of Intelligent Processor Nodes.....	15
3-3. Current Collection Systems .....	19
3-4. Global Grid .....	21
3-5. Global Connectivity.....	23
3-6. Hand-Held Access .....	24
3-7. Integrating Data Scenes .....	25
3-8. Mississippi River St. Louis, MO (Before and After Flood).....	26

## *Executive Summary*

This white paper describes the structure needed to integrate all sources of data and information with people, knowledge, skills and wisdom in order to fuel a concept called top-sight vision. Top-sight vision occurs when diverse players from different military services, and different political, cultural, and economic systems transcend personal and organizational imperatives and coalesce their vast information, knowledge, wisdom, and experience in order to achieve “community” objectives or goals that are of greater value than the sum of the individual parts. The amalgamation of trusting relationships provides insightful, holistic views of events, issues, activities, and/or situations. Since these relationships afford the opportunity to address all perspectives and points of view, the element of surprise is reduced and top-sight vision is achieved.

The objective is to capture the truth, learn an adversary’s mind and methodologies, anticipate responses, reactions, and identify intentions in time to plan and initiate preemptive strategies, employ countermeasures, formulate new strategies, and/or launch a decisive attack. The key is to seek and hold the high ground, whether on the battlefield, the global stage, or a combination of the two. In the alternate worlds of 2025, unilateral military actions against other nations will likely exist only in history books. Coalition decisions and warfare will be the normal mode of operations. Meeting these new challenges in 2025 demands new skills and specialized technologies.

Telecommunications now link nearly all areas of the world in which the economies already are dynamically interconnected. This expanding web of interdependence will continue to encompass political, diplomatic, and military relationships at levels unprecedented in history. To obtain maximum effectiveness, top-sight vision demands the world's best communication systems, "community" cooperation, a network of highly intelligent computers, and superbly responsive collection systems that have access to needed information, from open sources to highly sensitive intelligence.

All authorized users will have access to vital information when they need it, where they need it, and how they need it. The combination of data, access, and system connectivity is referred to as the I<sup>3</sup>S. The system will rely on an advanced architecture of communication systems, computer networks, and computer subsystems. It will employ AI, neural nets, and fuzzy logic to transform data into information, identify knowledge gaps, determine where needed information resides, cue collection assets, select alternate communication paths, and operate push-pull dissemination and access tools.

To support this system, a series of intelligent microprocessor "brains" working in an optical medium must be perfected, while new mediums for data transfer will have to be validated to minimize interference and maximize security. The intelligent microprocessor brains will be embedded throughout a distributed global architecture. These brains are needed to distribute processing, reduce single-point failures, maximize data integration, reduce timeliness, assure information flow and data access, improve subsystem responsiveness, and employ alternate communication paths.

The brain processors are all-knowing, all-sensing with regard to changes in the target environment, system status, sensor status, access, information demands, user needs,

people skills and expertise, as well as detecting sophisticated hackers violating the system. While much of the collected data would simply be archived and used to update historical trends and patterns, the I<sup>3</sup>S AI software would detect and assess target deviations, automatically alert appropriate users, and, as necessary, cue collection assets. This process ensures early recognition of enemy activities and intentions, while enhancing opportunities for survivability. During war, for example, new target locations or weapons parameters could be directly programmed into weapon systems of the United States and allied forces in time to effect a kill.

Another key attribute of this global information net is its commercial value. This system and its subsystems would clearly benefit all types of people and organizations. Imagine an airman in a battle environment or a plumber tapping into the net through a two-way wrist communicator to check the status of required spares or the next task. On the down side, cross-sector sharing demands that new techniques be designed for multilevel security protections. On the positive side, it means cost-sharing, which is vital for effective and efficient development and deployment.

This paper describes a multifaceted system that gives the US the high ground through rapid recognition of “hot spots,” insightful views of events from global or local perspectives, and improved decision processes. It also stresses the team approach across all elements that impact international relationships, warfare, and the decisions that surround warfare. The intent is to use all means possible to win all battles and to assure the superpower status of the United States well into the twenty-first century.

In detailing requirements, this paper primarily focuses on the technological tools that are needed to create the I<sup>3</sup>S. Although the need for cultural and organizational

changes are recognized, this paper does not address these issues in detail. Indeed, both topics are subjects for separate papers.



# Chapter 1

## Introduction

*Any military—like any company or corporation--has to perform at least four key functions with respect to knowledge. It must acquire, process, distribute, and protect information, while selectively denying or distributing it to its adversaries and/or allies.*

—Alvin and Heidi Toffler

Ensuring the superior defense of this great nation in a rapidly changing and diverse world requires new ways of doing business, new partnerships, vision, action, leadership, and advanced technologies. As we approach 2025, the increasingly complex and interconnected world demands a greater quest for knowledge and wisdom--a quest that is unprecedented in the history of mankind. Simply seeking wisdom will not sufficiently deal with the evolving issues that will confront world leaders in 2025. Integrating knowledge and collectively sharing wisdom, ideas, and concepts will significantly increase the opportunities for success. This cooperative and interactive process will become a prerequisite for superior leadership and decisive actions.

Never before in the history of the world has one nation emerged with the overwhelming power, strength, will, and leadership that the United States has. This singular superpower status calls for “top-sight”<sup>1</sup> (See Appendix) vision, a concept that

integrates diverse players from different backgrounds who transcend personal and organizational imperatives and coalesce their vast resources of information, knowledge, wisdom, and experience in order to achieve “community” objectives or goals. Top-sight vision can only emerge from collective wisdom that is built upon a diverse information network of integrated resources, open minds, collaborative analyses, and advanced communications and computer support systems.

Critical to future decision makers will be the strength of character and courage to acquire top-sight vision through openly sharing and exchanging views, information, knowledge, and wisdom, as well as personal experiences and instincts. A lightning-fast, on-demand, world-class information integration system will connect all authorized users to a diverse spectrum of data, information, and experts. Such a system would form the cornerstone of global awareness and serve as the prerequisite for information dominance.

Leveraging technology to dominate information, and to put that information where it is needed when it is needed, will be a significant force multiplier. Likewise, gaining complete access to needed information--and validating that information--will limit misinformation, enhance the opportunity for peace, and provide the basis for success in battle and speedy resolutions to crises.

Equally critical to this nation’s defense are accurate intelligence, on-time maintenance and logistics support, well-trained military forces and modern weapon systems. These are the essential building blocks that fuel and enhance key competencies for global awareness, global reach, and global power.

Although the world is a dangerous place, the future is indeed uncertain. Weapons proliferation, international crime, and territorial disputes, coupled with the increasing gap

between the “have” and “have not” nations, serve to make the world a far more dangerous place in which to live. The dimension and quality of the decision cycle to foresee and respond to looming crises will be highly dependent on the information that feeds it as well as the interactive and cooperative spirit of the decision makers.

This paper defines the structure that is needed to integrate multiple layers and diverse types of data and information to gain global awareness and achieve top-sight vision. In the world of 2025, technologies combined with effective information offer the best opportunity to know the adversary’s capabilities and to gain significant insight into intentions and reactions. There is no doubt that the side that best exploits information and gains top-sight vision will achieve the greatest advantage in resolving disputes and winning wars.

Gathering and synthesizing data into information, correlating information, and sharing knowledge call for sophisticated computer systems and advanced telecommunication networks. The systems must employ advanced parallel and distributive processing techniques. They must also employ secure broadband communications to dynamically link systems, collection resources, producers and users. The systems also must be compatible across all users. Both computer systems and telecommunication networks must be highly responsive to human and machine interfaces, innovations, and interventions, and they must automatically learn to adapt to changing needs. All systems must be accessible via interactive voice commands, advanced modems, cellular-type devices, and other as yet unknown technologies that will emerge.

These highly interactive computer systems and communication networks will form the backbone of the I<sup>3</sup>S, which is completely decentralized but is highly interactive from

anywhere in the globe, at any time. The flow, exchange, and integration of information, knowledge, wisdom, instincts, and experience are defined in the assessment pyramid (Appendix), which serves as the conceptual model for top-sight vision. This model also is the driver for changing cultural and organizational habits, which are prerequisites for successfully achieving information dominance.

The top-sight model of knowledge and information is designed around the functions of the human brain, a concept which encourages the integration of pragmatic and rational intellectual skills with the instincts and intuitions resulting from algorithmic identifiers and flags based on experience, insight, and knowledge. This system must be supported by seamless processing and data access, AI, secure communications, and computer systems that create a virtual global community where location is transparent, access is commensurate to a user's security level, and information access is supreme.

To reduce research and development costs and shorten cycle times, every effort must be made to acquire commercial, cutting-edge, off-the-shelf equipment and software. The information integration system for 2025 must provide in-time, on-demand, actionable intelligence to authorized users when they need it, where they need it, and in the format they need.

The I<sup>3</sup>S this paper proposes must give authorized users dynamic responses to requests for new data from anywhere and at anytime, determine what data already exists, and, automatically cue or alter collection resources to new or changing requirements. At the same time, the system must automatically generate feedback and status reports to users, inform them of actions taken, advise them when data will become available, and inform them of the requirements that cannot be satisfied.

The information revolution is a harbinger of notable changes in the conduct of war. As Martin van Creveld said in *Command in War*, “The history of command can thus be understood in terms of a race between the demand for information and the ability of command systems to meet it.” Consequently the United States must make a collective effort to establish the strongest I<sup>3</sup>S capability in the world.<sup>2</sup> The revolution in military affairs surrounding information dominance is as important and vital as the advent of steam propulsion, the radio, radar, the tank, or the airplane.

Whether preparing for warfare or diagnosing world events or issues, the need for global awareness has moved the need for information dominance to center stage. In the view of Gen John Shalikashvili, Chairman of the Joint Chiefs of Staff, “The commander who owns the information owns the outcome of the war . . . [m]y challenge is to meet the warrior’s quest for information . . . the right information, to the right person, at the right time, in the right place, in the right form to achieve victory for any mission.”<sup>3</sup>

The joint campaign should fully exploit the information differential, that is, the superior access to and ability to effectively employ information on the strategic, operational and tactical situation which advanced US technologies provide our forces.<sup>4</sup>

## Notes

1. Model created by the authors.

2. To realize this vision, Command, Control, Communications, and Computer Intelligence (C<sup>4</sup>I) systems must be built under a JCS unified strategy. These systems must then be embedded in all forces, ready to execute on demand. Information-based warfare systems must take the information high ground to integrate battlefield information and in turn increase the effects of maneuver and firepower. Properly designed, a system of this nature will be the ultimate force multiplier, with the ability to grow with the situation.

3. J-6 Directorate, Office of the Joint Chiefs of Staff, *C<sup>4</sup>I For The Warrior, Global Command and Control Systems, From Concept To Reality* (Washington D.C.: Office of the Joint Chiefs of Staff, 1994), 2.

4. Adm Jeremy M. Boorda, "Leading the Revolution in C<sup>4</sup>I," *Joint Force Quarterly*, no. 9 (Autumn 1995): 16.

## **Chapter 2**

### **The 2025 Challenge**

The dynamic and chaotic pace of today's world is not likely to slow down. Indeed, the pace will likely increase. Therefore, understanding and controlling information will be a significant core competency for warfare by the year 2025.

To meet future challenges, we must develop a system of systems that will survive research, development, and acquisition processes in light of a dynamic and changing future. Considering the proposed alternate futures for 2025, I<sup>3</sup> will be essential to decision makers. In some plausible futures, I<sup>3</sup> will be more important than in others, but all such studies agree that information will continue to be power. Consequently, the high ground of the future will be information dominance and global awareness.<sup>1</sup>

Creating thoroughly cooperative working relationships across all military services and the intelligence community is by far the most difficult challenge. Territorial imperatives, different data needs, varying roles and missions, alternate solutions to common problems, and differing visions are gargantuan impediments to success. Overcoming these impediments will require astute leadership, focused vision, and unprecedented cooperation among the services, intelligence institutions, industry, and academe. The areas where institutional inertia must be totally eliminated include information integration

and information dissemination. Data formats, databases, communication paths, and integration tools must be 100 percent compatible; leaders must have zero tolerance for organizational or institutional barriers..

Developing the concepts and means to selectively and rapidly move accurate information across a vast, secure cyberspace, while accurately fusing intelligence, detecting information deception, securing credible knowledge sources, and employing the laws of probability are the technical challenges for the next 30 years.

In addition to creating conceptual and managerial cooperation among disparate sectors within the United States, two specific problems must be tackled: stemming the high cost of developing software and limiting obsolescence that results when technology moves faster than equipment integration.

“Force Modernization is the Blue Print for [today’s tenets of] Global Reach and Global Power. Our Strategic Vision remains containment through deterrence.”<sup>2</sup> To accomplish this, the Air Force reorganized into Air Combat Command (Global Power) and Air Mobility Command (Global Reach). To realize this vision, the Air Force of the 1990s pressed on with the C-17 as the key short-term solution, developed upgrades in conventional capabilities to meet mid-term requirements, and pursued long-term planning for transatmospheric reusable lift capability to prepare for the future. As we step into the new millennium, and especially as we look to 2025, information dominance becomes the blueprint for success in maintaining global peace. Logically, an effective I<sup>3</sup>S transcends the entire spectrum of near- to long-term decision-making requirements.



## **Top-Sight Vision ⇒ Information Dominance and Security**

The top-sight pyramid model (Appendix) was selected because the broadest portion of the pyramid (the base) represents the repository of all available data, while the top segments represent the refined components of knowledge and wisdom. All segments of the pyramid are interactive, and these interactions take place in both horizontal and vertical dimensions. For example, synthesized data flows upward to fuel new knowledge and wisdom, which then refines or defines new needs statements that flow downward and drive the gathering of new data. Each face of the multi-sided pyramid represents a different actor or sets of actors (i.e., military users and planners, intelligence producers, policy makers, academicians, foreign partners or advisors, historians, scientists, economists, etc.). Players change issues as events or needs warrant. The process is highly dynamic.

On the horizontal plane, data, information, knowledge, and wisdom, combined with instincts and experience, are freely shared and exchanged in a virtual and highly interactive process. Information sharing works in any and all directions—laterally or vertically—and is applicable at all levels of an organization, from the lowest level to the most senior levels. It is the integration and cooperation of the various levels and dimensions that add the value to the top-sight model.

The bottom two layers of the pyramid—data and information—are heavily reliant on machine processing and interfacing technologies and generally answer the basic intelligence questions of *who*, *what*, *where*, or *when*. Patterns of activities and trends also emerge from these levels. These are the levels where other sensors can be cued and

interested parties alerted to ongoing activities and changes in the environment. As this information scales the structure of the pyramid and moves into the upper two layers (knowledge and wisdom), the human-to-human and human-machine interfaces become vitally important, as actors and machines work interactively to answer the *how*, *why*, and *what if* questions.

To make this highly dynamic and responsive model operate effectively, vast computer systems and telecommunication networks must support the cross-organizational integration of players and databases and provide those players with the tools to fully exchange data and discuss specific events, issues, or needs. The multidimensional aspects of the model forms the basis for cohesive, integrated, and validated knowledge, leading to information dominance and global awareness. Achieving global awareness is the ultimate top-sight vision (Appendix).

Dominance of the information spectrum is required to maintain our national security. Failure to maintain or exploit this dominance will have precisely the opposite effect. Decision makers must have this top-sight vision in order to be able to make the necessary choices in crises and non-crisis situations. In 2025 global events will demand astute decisiveness. Knowing what is transpiring, and having on-demand access to quality data, knowledge, and expertise, will provide a tremendous advantage for effectively maintaining security--a prerequisite for success.

More importantly, having others know that we can know and respond to what is occurring creates a powerful deterrent to hostile activities throughout the world. Such deterrent capability adds to the value of the knowledge itself. Information dominance can create a presence which, in many cases, may substitute for forward deployments of

military forces. For example, instead of sending a carrier air wing into the South China Sea to show the flag in response to an impending crisis, the President could contact various world leaders and attempt to employ the vast knowledge of multiple players. This would allow the surrounding countries to intervene and possibly stop a crisis without the deployment of United States forces. Thus, information dominance could diminish the logistical problems of transportation and sustainment while reducing the risk to American lives. Should conflict become a reality, the in-time information integration system and the top-sight model would provide powerful tools to engage the adversary's forces; anticipate their actions, reactions and intentions; respond decisively; and maneuver and outwit their leaders.

The quantity and quality of information that can be gained through the integration process will enhance our national capabilities--commercially as well as militarily. While many consider space to be the ultimate high ground, information dominance--the ability to see the other side of the hill--is truly the ultimate high ground. Information dominance is the only vantage point from which to attain top-sight vision. This information dominance will ensure US security well into the twenty-first century.<sup>3</sup>

### Notes

1. USAF Scientific Advisory Board, *New World Vistas: Air and Space Power for the 21<sup>st</sup> Century*, summary volume (Washington, D.C.: USAF Scientific Advisory Board, 15 December 1995), 57.

2. Gen Ronald Fogleman, Chief of Staff, US Air Force, address to the 2025 participants, Air University, Maxwell AFB, Ala., 13 February 1996.

3. Adm William A. Owens, "Four Revolutions In Military Thinking," *The Officer* (August 1995), 29-32.

## **Chapter 3**

### **The In-Time Information Integration System (I<sup>3</sup>S)**

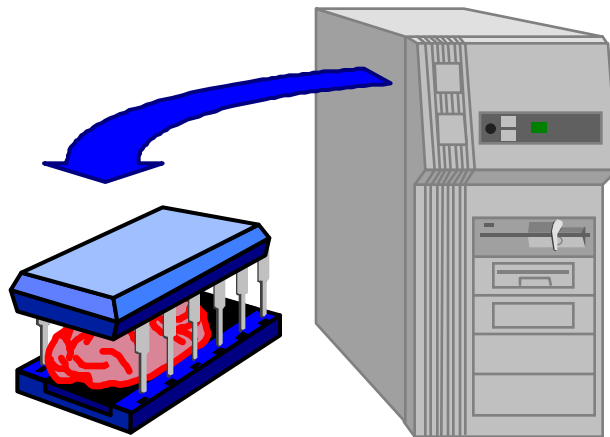
With interoperability and modifications to current technologies taking us into the year 2000, it is imperative that we focus on new technologies for information dominance in 2025. If we are going to give our warriors a “fused, real-time, true representation of the warrior’s battlespace—an ability to order, respond, and coordinate horizontally and vertically to the degree necessary to prosecute his mission in that battle space,”<sup>1</sup> --we must develop a significantly faster and more capable system for 2025. This system must be capable of much more than simply providing a warrior with the battlespace picture. This system must be able to take in all possible data and make algorithmic decisions concerning that data. It must be able to provide our decision makers with a vision into the enemy’s observe, orient, decide and Act (OODA) loop.<sup>2</sup>

The goal of the I<sup>3</sup>S is to dominate the information battlespace by getting the right information to the right place at the right time. With this, our military will become an information-driven force that relies upon global situational awareness to effectively plan and execute complex missions with minimal risks. Civilian and commercial applications are also envisioned and discussed later in this paper. Crucial to this system is the ability to process raw bits of data, from collection sensors or existing databases, into information

which can be displayed to a human interface and transformed into valuable knowledge, which when integrated with human experience, yields an appropriate decision and/or action.

The vast amounts of data from today's collectors have already produced more information than human analysts are capable of evaluating. Data production from collection sensors in the future will make the problem worse. The increased operations tempo of the future will increase the need for automated integration of information and the requirement for an I<sup>3</sup>S.

At the heart of this system is an intelligent microprocessor or a computer with a brain (fig. 3-1). This device enables the system to perform automated, intelligent processing on vast amounts of data from all sources to ensure that the right information gets to the right place at the right time. This is the 2025 evolution of artificial intelligence, neural nets, and fuzzy logic.

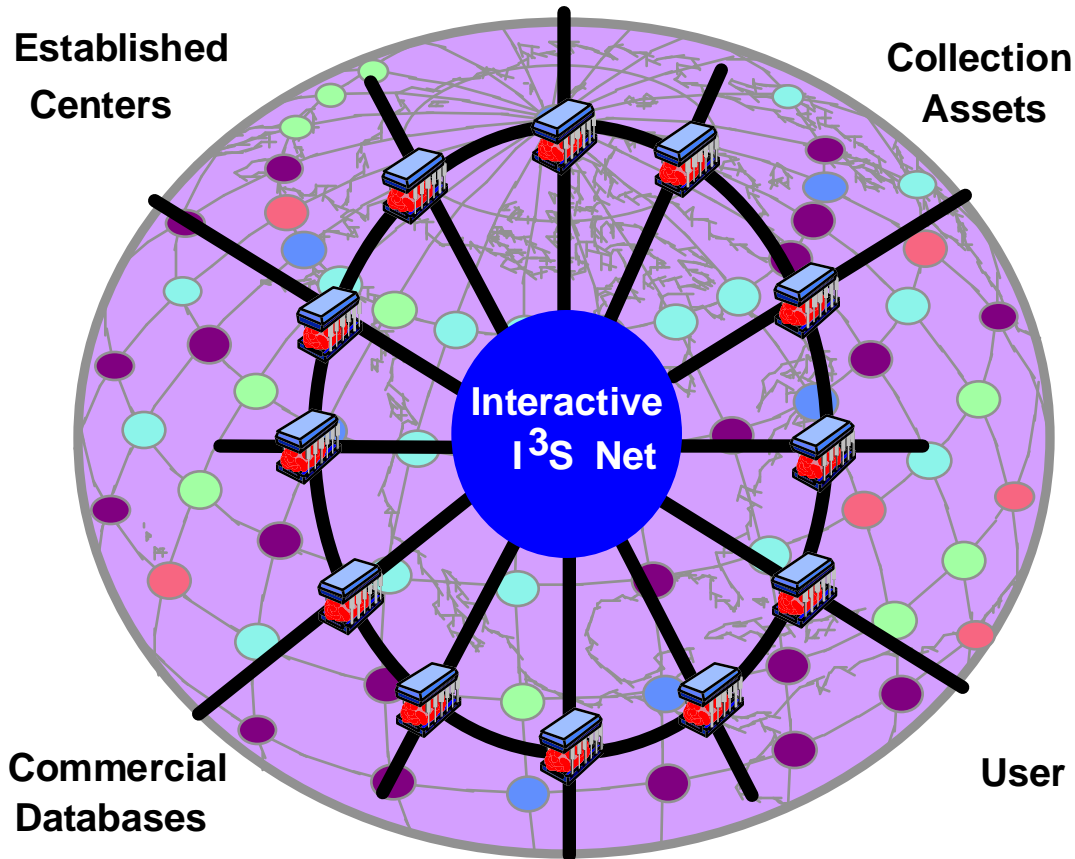


**Figure 3-1. Intelligent Microprocessor "The Brain"**

This intelligent processor has the ability to recognize a particular user's information needs and to automatically perform the necessary integration of the appropriate data to

produce the desired information product. The information contained in this product depends upon the needs of the requesting user. The user may also provide feedback to the intelligent processor to customize or tailor an information product in response to specific needs or situations.

The first function of the intelligent processor is to analyze the needs of the user. It may either identify the user and default to predetermined request parameters or respond to specific user tasking requests. The processor's brain also associates an appropriate classification level and processing priority with a particular user. Once the analysis of the user's needs is completed, the system brain determines what data it requires to complete the tasking. Identification of data requirements automatically triggers brain neurons to perform a network data search. This is where the intelligent processor linked to a specific user now interacts with other intelligent processor nodes linked through a distributed architecture (fig. 3-2). Through this distributed architecture, the processor has direct access to raw (real-time) and/or pre-processed (near-real-time) data from collection assets as well as worldwide archival databases.



**Figure 3-2. Distributed Architecture of Intelligent Processor Nodes**

The user in figure 3-2 may represent anyone from a single infantry soldier to the National Command Authority (NCA), including civil and commercial users. Collection assets in figure 3-2 represent all sources of data (e.g., imagery intelligence [IMINT], signals intelligence [SIGINT], measurement and signature intelligence [MASINT], human resource intelligence [HUMINT], early warning [EW]) from any land, sea, air, or space platform. The established centers referred to in Figure 3-2 represent databases and/or processed information available from the Department of Defense and national agencies (e.g.: Central Intelligence Agency [CIA], Defense Intelligence Agency [DIA], National Security Agency [NSA], Defense Mapping Agency [DMA], National Photographic

Interpretation Center [NPIC], SPACECOM) or whatever they have become in 2025. Commercial collection systems data, such as multispectral imagery from LANDSAT and SPOT, would be found in the commercial databases along with future commercial systems data, including data other than imagery. Information from Lloyds of London, for example, may provide valuable insight to maritime traffic (i.e., ship registration, point of origin, destination, cargo, etc.). The intelligent processor nodes and their linkages noted above by no means represent a finite set and are limited only by a decision maker's imagination.

As the intelligent processor linked to the user receives data/information from other processor nodes in figure 3-2, the integration process for the user's information package begins. The phrase "data/information" is used above to indicate that the user's processor may receive more than just bits of data over the nodal net. An intelligent processor node connected to an established center may transmit secondary intelligence products created through manual processing and/or human interfaces. Conclusions from experienced human analysts may also be included for integration if required by the user's processor brain.

After the data/information search has completed, the user's processor may sense a requirement for additional or more recent data/information. This will automatically initiate tasking requests to appropriate collection assets through the proper nodal connections. If the processor determines that it has sufficient information to be of value to the user, the processor would forward the integrated information ("as is") to the user along with a status report indicating the additional tasking request and potential package update.



Note that it is not the intent of the intelligent processor brain to replace all human interfaces. Furthermore, it is not envisioned that the processor brain in 2025 will be as good as a human brain in reaching conclusions and/or decisions; it is necessary however, to facilitate the enormous processing and synthesis of data required by the systems of 2025 that will become uncomprehendable to a human brain.

Intelligent processing is not that far away. Today we teach computers what not to look for in the form of change detection software algorithms. Computers quickly scan thousands of frames of images and detect small changes which may represent targets or threats.<sup>3</sup> Neural nets are used to optimize targeting of defense systems where speed is of the essence, allowing computers to complete analyses of multiple threats and multiple defense systems on a time line that is impossible for humans to meet.<sup>4</sup> A computer uses fuzzy logic to analyze elements in the rinse water of a washing machine to determine whether the clothes require further washing, then automatically adjusts the cycle accordingly.<sup>5</sup>

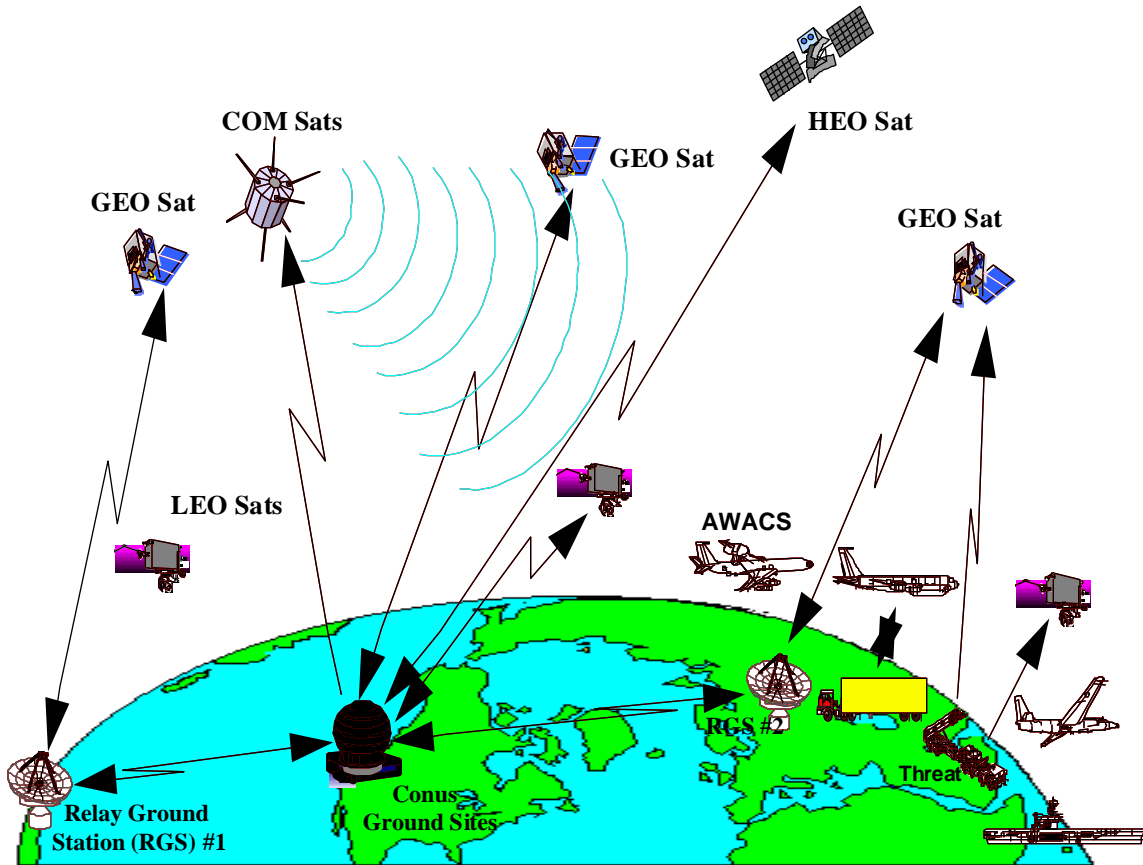
A host of commercial products that perform data fusion for specific purposes and display the resulting information with easy-to-comprehend three-dimensional graphics are available today. Software products such as Autometric Corporation's "Omni" combine with "Talon Vision," an Air Force Tactical Exploitation of National Capabilities Program (TENCAP) product, to perform an admirable job of displaying near-real-time OP-ELINT situational awareness.<sup>6</sup> Unfortunately, their capabilities fall significantly short when processing varying types of data (e.g., raw imagery, processed imagery, radar phase history data, SIGINT, HUMINT) and/or adapting products to the dynamic needs of different users. "Today's fusion systems, whether embedded or built upon open

standards workstation architecture, are primarily custom-built stand-alone software designs built to the unique needs of a particular project or military task.”<sup>7</sup> Limited connectivity and access to information databases continue to severely handicap today’s systems. The challenge for 2025 is to provide in-time integration of information from all sources with global dissemination to all levels of users.

This is not intended to imply that all processing in 2025 will be or needs to be automated. Storage media will exist to store vast amounts of raw sensor bits that can be retrieved by those having specific needs that require special processing. It is envisioned, however, that this higher form of automated intelligent processing will satisfy the needs of many users while reducing the inevitable information overload to a level of acceptable comprehension.

Current collection systems (fig. 3-3) fall significantly short of maximizing the utility of their products through effective and efficient integration. Different collection systems viewing the same event, or the same collection system viewing an event from a different geometry, result in duplicate reporting with different results. On numerous occasions, this has led to confusion relative to missile launches and surface-to-air threats.<sup>8</sup> The linkage of a user’s intelligent processor to the intelligent nodes of collection systems will make time discrimination and geolocation data available for immediate integration of information into a single product with much higher fidelity. The product may become further enhanced through integration of related information from existing databases. For example, two SIGINT collectors may produce two different geolocation error ellipses for a particular threat. Integrating the information from the two collectors can result in a single error ellipse with greater geolocation accuracy. A simultaneous search for data

relative to the area represented by the error ellipse may result in IMINT or HUMINT confirmation to further pinpoint the location. Another benefit from nodal connectivity is the ability to immediately task or cue other collection assets for new data. Updates to previously released integrated information packages would occur as new data are acquired and a higher fidelity product becomes available.



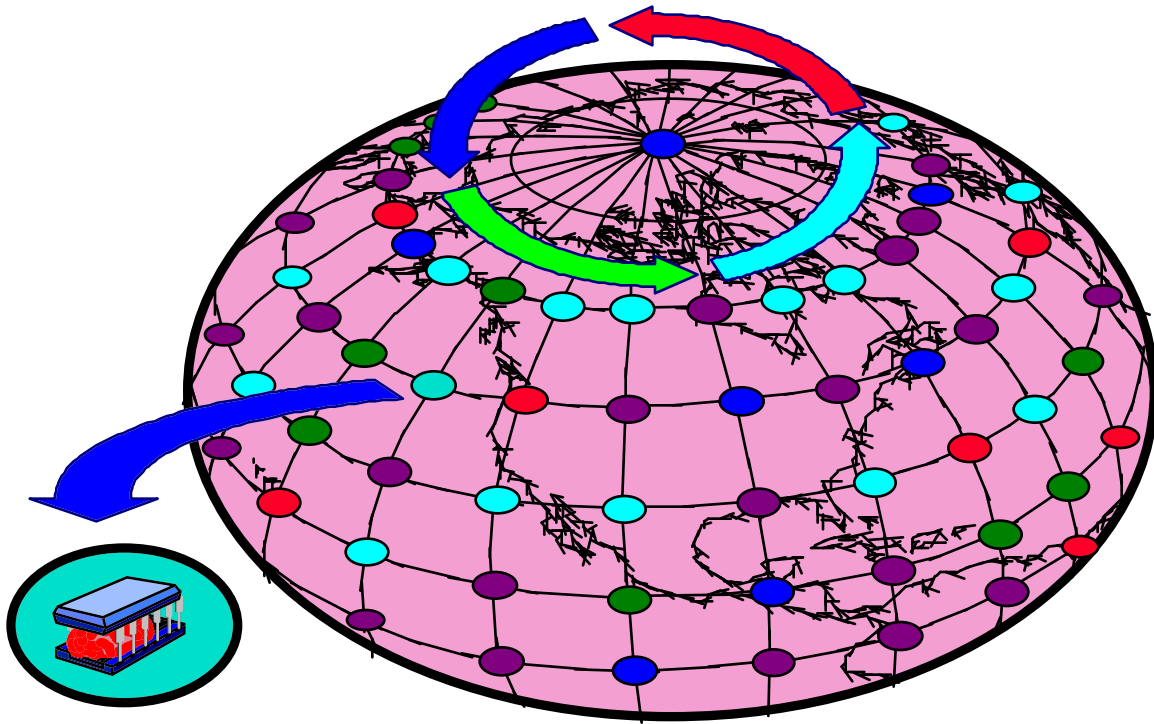
**Figure 3-3. Current Collection Systems**

Integration of local HUMINT with these information packages could even provide an enemy's intent to a user, instead of simply reporting facts. An intelligent processor could be programmed to recognize certain signals or events as it processes information in an area. When triggered, the processor brain would initiate an information request from

expert analysts, and other HUMINT sources for integration into an information package which will alert the user of a calculated or probable intent of the enemy. This analogy could also work for enemy weapon systems. The intelligent processor would recognize certain events as it processes information, then synthesize when and where an enemy intends to deploy a particular weapon system (rather than simply reporting the weapon's existence).

Connectivity is an instrumental feature of this system. A global grid of multiple intelligent plug-in nodes is envisioned (fig. 3-4). These intelligent processor nodes, either land-, sea-, air-, or space-based, are connected through secure fiber optic trunks and transmitted through atmospheric and/or space mediums only as necessary. The trunk size (i.e., bandwidth) is determined by the expected needs of the user. For example, it is reasonable to assume that a joint task force commander would have more requirements for a larger communication trunk than an infantry soldier in the field. This not only preserves the economy of available bandwidth, but also aids in system security by limiting a potential compromise of information.

# Global Plug-In

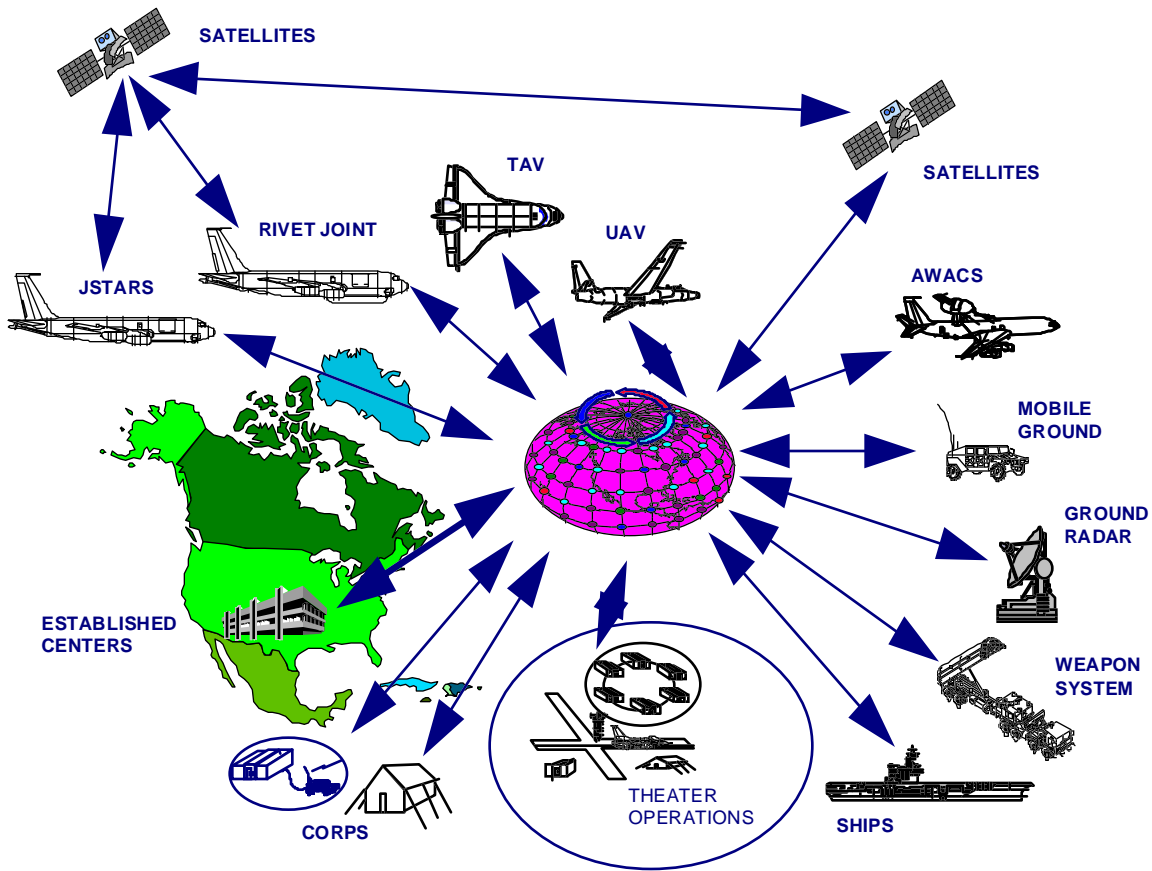


**Figure 3-4. Global Grid**

The brain of the intelligent processor has the ability to recognize and respond to multiple users on the same node. The brain can associate a specific security level and set information parameters to each user on the node. The information parameters would aid in minimizing the system's overall workload by limiting the processing of certain information to a particular user. In other words, the processor would not respond to an infantry soldier's request for information on deep-strike targeting. This is intelligent processing based on "need-to-know" parameters. The brain would also assign predetermined priorities to each user (which, of course, could be modified at any time by a higher authority).

Even with the speed and complexity of the intelligent processor in 2025, one can envision nodal saturation and temporary shutdowns of specific nodes due to information and user overloads. The global grid connectivity and distributed architecture displayed in figure 3-4 will accommodate instant work-arounds to recover from both unintentional and intentional outages, possibly from enemy attacks. The intelligent processor will also have different processing states. During a crisis or information crunch, for example, the processor brain could resort to a reptilian state, performing simpler processing to produce only that information absolutely necessary for the user. The brain of the processor might also change states and become a channeling node, thus delegating intelligent processing functions to other distributed nodes.

This system would also function as a super global situational awareness tool. By monitoring the processed activities of other intelligent nodes on the distributed network, each node can supply global situational awareness information (figure 3-5). Activities, intentions, data, and information from all users and collection systems are quickly integrated into a visual three-dimensional display to facilitate user comprehension. This global connectivity facilitates the sensor-to-shooter concept of today while supporting a sensor-to-weapon concept for 2025.



**Figure 3-5. Global Connectivity**

In figure 3-5, one can envision the system utility and effectiveness of providing all decision makers (e.g., joint task force commanders, ship commanders, air commanders, ground commanders) with continuous global situational awareness by directly linking their intelligent processing nodes. This not only provides them direct access to human analysts and collection assets; it also allows everyone access to the same information, including feedback, to facilitate the coordination of activities among each other.

Display systems would be commensurate with the users needs. An infantry soldier in 2025 will replace his global positioning system (GPS) receiver with a hand-held digital display unit (fig. 3-6). This unit will access an intelligent node and provide much more

than a GPS location. The intelligent processor could highlight potential travel routes for avoiding adverse terrain and/or enemy positions.

## GLOBAL PLUG-IN

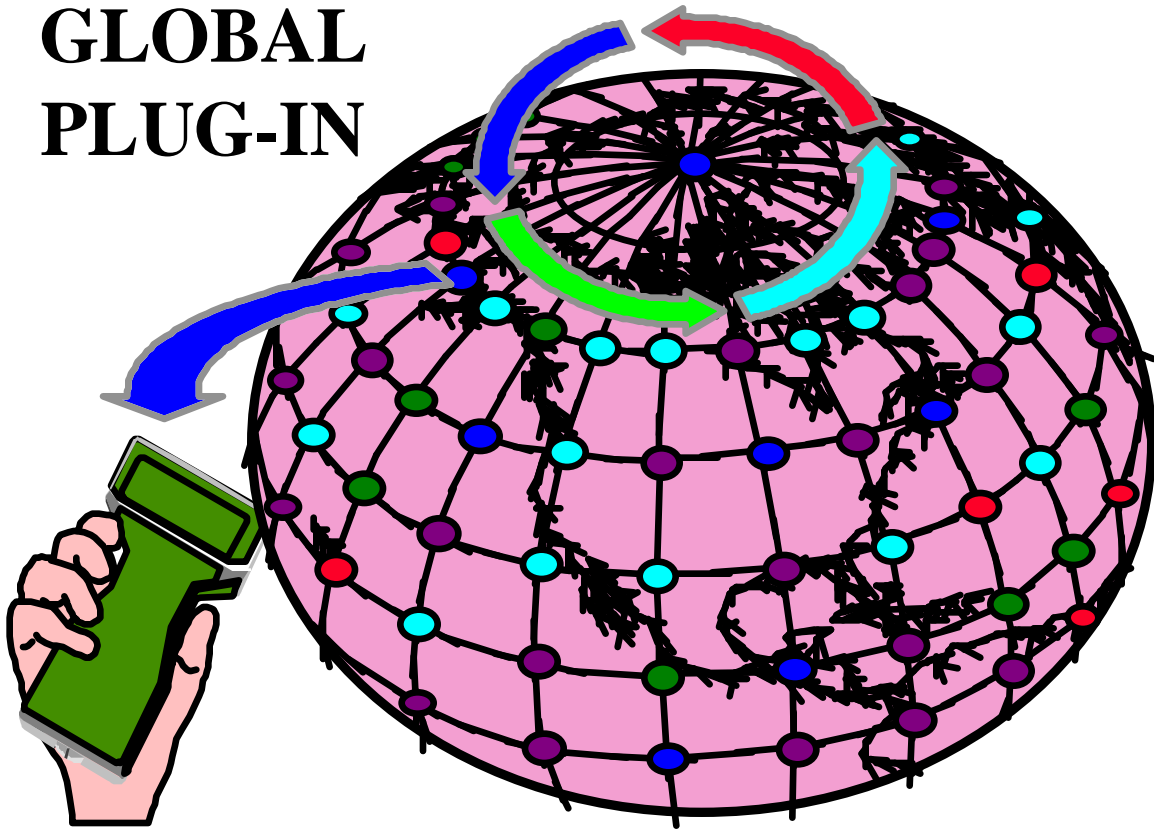
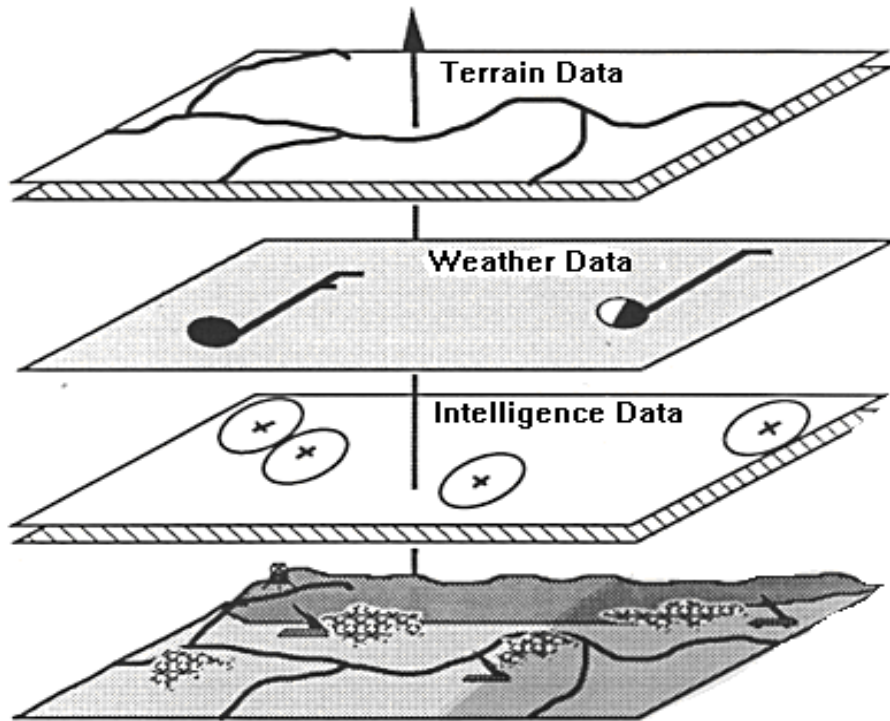


Figure 3-6. Hand-Held Access

The system accomplishes this by searching the nodal net for multispectral images of the area; LANDSAT and/or SPOT data would suffice today. The processor brain would process the multispectral images to produce terrain categorization (TERCAT) maps. These TERCATs are then integrated with digital elevation data, possibly from a DMA database, to produce trafficability maps ( go, slow go, no go). The processor brain would search the nodal net for the latest information on enemy positions and strengths for the



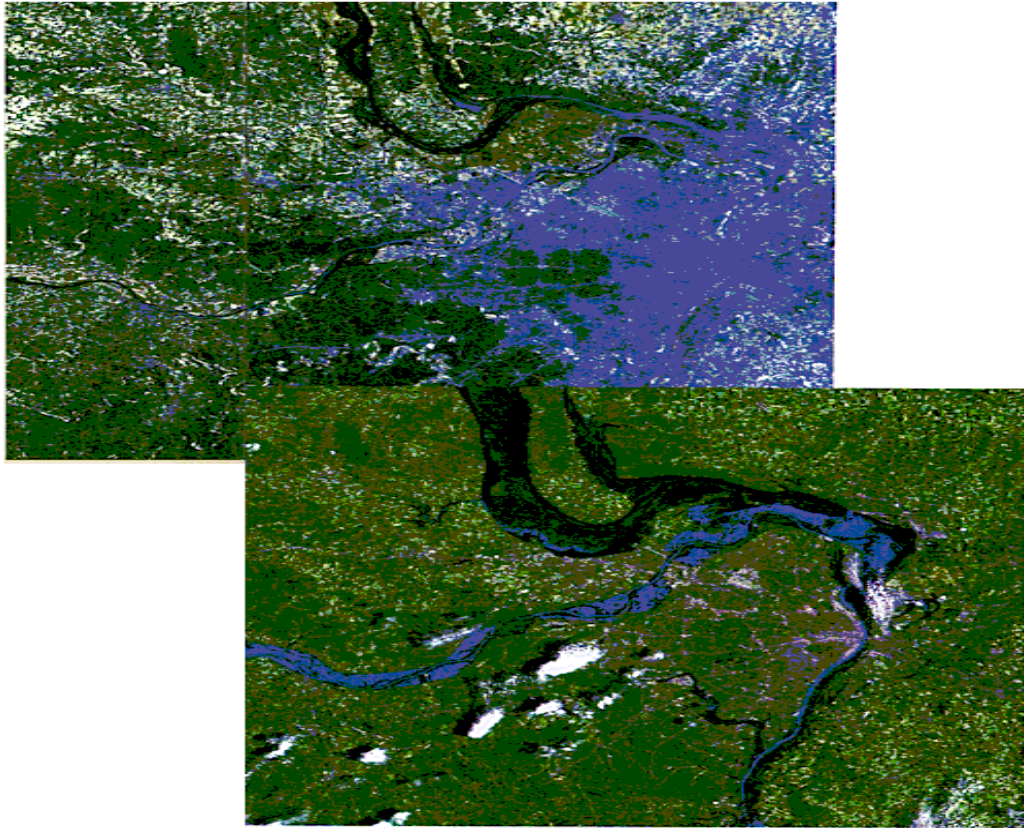
area of interest, overlay this information on the trafficability maps, determine probable travel routes, and display the results to the user (fig. 3-7). The intelligent node could also perform simpler functions such as confirming target coordinates to artillery soldiers after verifying the latest intelligence information and the commander's intent.



**Figure 3-7. Integrating Data Scenes**

It is easy to envision a host of civil and commercial applications for a system such as this. For example, a civil engineer who wishes to relocate a town destroyed by flooding may request historical information on the various flood stages of a river in a particular area. The brain of the processing node would identify the user as unclassified and assign a priority to the request. The intelligent processor would in turn prepare an integrated information package for the user. The intelligent processor would most likely use

LANDSAT multispectral data from an EOSAT archive, together with DOD change-detection algorithms, to generate true-color, composite-image maps highlighting the various water levels and affected areas (fig. 3-8).



*Images courtesy of the Defense LANDSAT Program Office*

**Figure 3-8. Mississippi River St. Louis, MO (Before and After Flood)**

Although this level of processing exists today, it is not readily available and affordable for general population use. It is envisioned in 2025 that civilian organizations and/or companies who can afford a GPS receiver today could have access to a commercial grid of information. Imagine in 2025 auto clubs planning trip routes and issuing image maps that display current road conditions, construction, detours, and alternate routes (including scenic).

## **System Security**

System security is addressed in several ways. All classified data, and information determined classified as a result of synthesizing unclassified sources, is linked to nodes through encrypted communication trunks. Deciphering occurs at the user terminal and is further controlled through the intelligent nodes' recognition of the user. Recall that the intelligent node limits information passed to various users based on their requirements and/or need-to-know. This becomes important should the enemy should capture a user terminal. Potential compromise of information is limited to the authorization level or access level of the particular user terminal.

The most vulnerable user terminal, most likely a field soldier's hand-held display, also has the lowest authorization or access level. Information compromised at this level would have little value for the enemy. The higher-access-level terminal of a theater commander would be guarded more securely. Any capture at this level would be readily known.

Once the intelligent node recognizes the user terminal as compromised, either through unauthorized information requests or direct (human) reporting, it would alert higher command and await instructions. Higher command may wish to use the captured terminal as a conduit to pass misinformation to the enemy, or it might terminate service to that particular terminal. For more information, see the 2025 Information Warfare paper.

This system meets the demanding challenge for 2025. Not only integrating information on objects with much greater fidelity than is possible today, but also processing information orders of magnitude faster with global dissemination into an easily comprehended display format. The technical evolution of computers, communications,

and sensors will make it possible to provide a continuous, near-real-time picture of the battlespace to war fighters and commanders at all levels. This situational awareness capability is truly the key to achieve information dominance in 2025.

### Notes

1. Adm Jeremy M. Boorda, "Leading the Revolution in C<sup>4</sup>I," *Joint Force Quarterly*, no. 9 (Autumn 1995): 17.

2. Col John Boyd (Ret.), "Observe-Orient-Decide-Act (OODA) Loop," address to the 2025 participants, Air University, Maxwell AFB, Ala., October 1995.

3. Capt Edward Swedberg, Chief LANDSAT System Utility Branch, interview with Major Adair SAFSP/ DLPO, Washington, D.C.

4. Ibid.

5. Ibid.

6. Maj Joseph Crownover, Air Force TENCAP Project Officer, interview with Major Adair, HQ USAF/XORR, Washington, D.C.

7. Dr Charles L. Morefield, "Situational Awareness in the 21st Century," USAF Scientific Advisory Board, *New World Vistas: Air and Space Power for the 21<sup>st</sup> Century* (unpublished draft, the information applications volume, 15 December 1995), 25.

8. Col Gary Armistead, Surveillance and Reconnaissance Requirements Division, interview with Major Adair, HQ USAF/XORR, Washington, D.C.

## **Chapter 4**

### **Concept of Operations**

Imagine looking down at the earth from a position in space. You are far enough away that the earth appears as a small sphere and other planets can be seen in the distance. You distinguish movement and notice that it is the earth rotating about its axis and the moon revolving around the earth. Instantly, you realize that this is not a static picture display, but a very dynamic three-dimensional, computer-generated model with a simple control box in front of you.

Glancing at the control box, you notice a “Zoom” function and decide to explore the zoom-in feature of the system. As the earth gets larger, little mechanical bodies of various sizes and shapes surrounding the earth begin to appear. These objects are quickly identified as satellites; however, there are so many that the image of them appears blurred. Fortunately, the system has an isolation feature that allows the viewing of these satellites either one at a time or in any combination desired. The operator simply chooses which satellites to display and which to temporarily mask. Once the satellite(s) of interest is identified, a window appears on the display containing detailed information on that satellite or satellite system. A wealth of information is instantly available at a glance (e.g., origin, purpose, capabilities, orbital parameters). To facilitate understanding and

comprehension, the information is conveyed visually whenever possible. This allows the user to quickly comprehend and easily understand at a glance what may previously have been considered too complex or time-consuming to trouble with.

For example, after a particular satellite or satellite system is isolated, a time control feature is used to enhance understanding of complex orbital parameters and mechanics. In the real-time position, the display indicates the particular position of the satellite at that particular moment. Adjusting the time control forward or backward will display the satellite's position at any particular time, either past or future. Employing a compressed time mode (one second equals five minutes) creates a dynamic display of the satellites orbital parameters. Visually cueing on the satellite's motion around the earth quickly conveys an understanding of the orbital parameters to the user. Rotating the user's perceptive view of the earth (e.g., looking down on Korea versus the Middle East versus South America), or even displaying the view from the satellite as if the user were on board and dynamically viewing the earth below, are software features which further the user's understanding of the satellite system parameters.

Using these features, a user could examine various satellite systems at a glance and immediately discern crucial information: Where satellites are now and where they will be at a particular time, what their fields of regard<sup>1</sup> and fields of view are, any coverage gaps to exploit, what their function is, how and to what their data is linked, how to minimize the utility of others while maximizing yours, and much more. These questions merely scratch the surface of the amount of information available through a top-level examination of a satellite system. The real advantage is in the integration of available

information and the dynamic three-dimensional display which quickly and easily conveys information to the user.

Taking this another step, imagine that the display system or receive terminal is as compact as a lap top and that the information source feeding it is available anywhere, anytime. Furthermore, imagine that the information source is a “smart” source that it identifies the user connected and knows what information is required, and that it even knows the priority. This “smart” source, or intelligent processing node, would search existing databases and sources for information, automatically integrate an information package for the user, and forward tasking requests to assets for additional data when only insufficient data is available. If the intelligent processor required additional information, but determined that the existing information was useful to the user, the user would receive a preliminary information package and near-real-time feedback on the status of the final package. For example, this feedback would identify which data were insufficient to complete the request and/or indicate any forwarded tasking requests, along with the status of those tasking requests. The tasking status report would identify which assets were tasked, the priority evoked, and when (if at all) the user can expect completion and receipt of an updated information package. This would allow a decision maker to employ other assets to augment any expected shortfalls and/or explore alternative options. The data shortfall, for example, may generate a Unmanned Aerial Vehicle (UAV) sortie or require the launch of specialized microsat to supplement existing data sources.

Information on space systems is only the beginning. Zooming in closer, about a few hundred kilometers, most of the satellites disappear behind the display and the few low

flyers that remain are suppressed by use of the masking function. At a few hundred kilometers the full view of the earth is lost and the image rotating function is used to rotate the earth below us and change the perspective view of the display. The earth is rotated until the United States is centered in view below. At this distance, you cannot see coast-to-coast, but most of the 48 CONUS states are in view. Zooming in further fills our display with a 30-meter resolution true-color image of the ground below. The displayed picture is a composite of broad area images from a “LANDSAT/SPOT-like” system that has been geo-rectified and automatically correlated to the correct position on the earth. All this is transparent to most users who simply see 30-meter resolution true-color images. Topography such as rivers, mountains, plains, major roads, rail lines, and so forth, are clearly visible and easily distinguished.

Now let's say the user adjusts his controls to display terrain categorization and/or trafficability maps of the area below. The “smart” source would sense the request and integrate multispectral and digital elevation data under user-specified criteria from various systems/databases. This integrated product package is immediately available to the user's terminal.

The integration function, depicted in figure 8, is completely transparent to the user unless certain required data are unavailable to the “smart” source. In this instance, the user is made aware and is provided status through the feedback report mentioned earlier. The user could even request historical data from any open terminal which would prompt additional integration and data searches by the “smart” source. For example, the user may wish to display the various flood stages of the Mississippi River for locating new towns or potential crossing points. The “smart” source would perform a data search,



apply an automated change detection algorithm, and make the integrated information package, tailored to the user's request, available at the requesting node.

This kind of information has enormous utility to the military and civilian populations. The "smart" source will sense the user, determine the authorized classification level, and make only the appropriate information available. It will also determine the user's priority and process the request accordingly.

If more detail is required in a particular area, the user simply zooms in until the required resolution is displayed. Actually, the user is simply transitioning through various levels of imagery from multiple sources. The system has produced an integrated package of an area by overlaying georectified images with control/reference points and ensured the accuracy to a level commensurate with the user's needs and security classification. In other words, you start with a picture of the earth, zoom in on a continent, then a state, then a town, perhaps a building, and finally down to a small window of particular importance. The system simply transitions through various sources of imagery which is automatically integrated by the "smart" source and completely transparent to the user. Once again, if the data required to produce the requested integrated product are not immediately available, an automated tasking request is forwarded to collection assets, followed with a status report to the user.

The user is now interested in a different kind of information in a different part of the world. Let's zoom out from the building window for a moment to display an area about 1500 NM X 1500 NM. Now rotate the earth until Iraq is centered below. The user wishes to visualize the air picture over Iraq. This request is immediately sensed by the "smart" source, which begins to integrate the data from all sources and provide an

integrated information package based on the requested criteria from the user. Within seconds, an extremely cluttered and confusing gaggle of multicolored, multifigured, and multiidentified icons appear overlaid on the image of Iraq. Tiny blue F-22 icons, blue C-17, UAV-3, TAV-2, E-5, and other coalition aircraft are smeared on top of yellow unidentified, white commercial, and red Iraqi aircraft. Since the user did not specify a time period to display, the system defaulted to the last 24 hours of reported activity in the region which virtually saturated the display with reports.

The user now specifies a request for more recent information, specifically the last 15 minutes of activity in the area. Within seconds, a much less cluttered display is observed and the user can quickly see the aircraft currently in the area and the flight paths linking associated aircraft. Some areas with multiple aircraft may still appear confusing, but zooming in on those particular areas quickly resolves any confusion. The user may also notice changes and additions as the system attempts to automatically update the display with the latest information available. At this point the user decides to overlay the latest threat (anti aircraft artillery (AAA), surface-to-air-missiles (SAM), radars) information. The display refreshes, and color-coded icons for target tracking, surveillance, and air traffic control radars, and other potential threats appear. The associated error ellipses for the threats are also available and can be displayed at the discretion of the user. Again, transparent to the user is the integration of data from multiple collection sources, which also contributes to the associated accuracy of the information displayed.

If the user desires, he/she can zoom in on a particular threat to whatever level of imagery is available. In some cases where data is limited, only the terrain around the threat may be immediately available. An information window is also available, indicating

known specifications on the threat along with the original source of information. The user can also zoom in on a particular aircraft to receive more detailed information. Similar information displays can be generated to provide situational awareness for the ground and naval forces also. Through use of the zoom feature, the field of view for situational awareness can be controlled to display the entire theater or any particular region of a theater. The particular theater or region of interest and display information are controlled by the user.

What the user has is an invaluable tool which can provide a global situational awareness of whatever the user specifies, and display the information in a three dimensional form that is quickly and easily understood at a glance. The fact that the display is small and portable so that the information is available anywhere at anytime adds to the tremendous utility of the system.

A subtle but extremely noteworthy and essential feature of the system is the capability to integrate information from IMINT, SIGINT, HUMINT, MASINT, surface, air, and space collection assets, as well as commercial and civilian data, to provide the highest fidelity product possible (fig. 3-5). Breaking through existing security, interoperability, and organizational barriers is the first challenge to total system effectiveness.

### **Notes**

1. Field of regard refers to the area a satellite has coverage of; a satellite may have coverage from horizon to horizon, but may be able to see only a fraction of its coverage area at any given instant of time (field of view).

## **Chapter 5**

### **Enabling Technologies**

Implementing real-time space and reconnaissance information systems and the concept of a global grid of multiple intelligent plug-in nodes as a reality depends on a number of things, but in 2025 it will focus on the I<sup>3</sup>S. The I<sup>3</sup>S will be a virtual shopping center of information containing many different sources (stores), allowing each customer to “shop” the sources that will provide the needed information. To create the I<sup>3</sup>S; to achieve the level of information demanded; and to develop the storage capacity, processing speed, and individual information analysis loops needed to support it will require significant leaps in technology in the next ten to fifteen years.

To achieve this goal, many factors must be considered. These include the availability of financial resources, the overall state of the world economy, differential rates of technological advancement, political leadership, decisions on the relative priorities on the national agenda, and the overall stability of the world scenario. While these factors make predicting future events and technological advance very difficult, some certainties do exist. Consumer technologies will achieve rapid and continuous progress because of the commercial incentives and private demand for advancement. Joint venture technologies, between the private and public sectors, may not achieve the same kind of advancement

due to the limited funding that the public sector can provide and the private sector's being unwilling to fund projects that will not return the profit margins expected by stockholders. Unlike the past, it is less and less likely that public funds will be used for purely military technologies. Consequently, in order to fund an information architecture that can function on demand to provide the kind of total capability needed in 2025, the public sector needs to establish a joint office to work with the private sector for developing and sharing the required technology.

This vision of the future, with "in-time" access to the information required, will be heavily dependent on quantum leaps in telecommunications, computer, and sensor capabilities. Many of the technologies needed for 2025 are in the minds--and on the drawing boards--of scientists today: total fiber networks; satellites operating in the 100 GHz range and above; terrestrial fiber links operating in the tera-bit range; computers using optics, DNA, or proteins instead of electrons; and cheaper, more articulate sensor systems hosted on space, airborne, and ground platforms.

### **Telecommunications**

Requirements by the year 2025 for personal, business, and military communications will surpass anything thought of today. The globe will be a virtual network with near instant connectivity to almost any person, almost any place, as depicted earlier in figure 5. "Telecommuting, by 2025, will be telepresence--the ability to "be" where you really want to be and still operate in a very real way. Voice, video, data or any combination will be available in real time without distortion or sacrificing quality of one for the other."<sup>1</sup> Traditional narrowband (voice) and wideband (data) internetworking will be joined by a

new category, “broadband.” “Broadband services are just being identified and understood, as we pursue applications such as videophone, high-definition TV, image transfer, and supercomputer-to-supercomputer connectivity. . . .”<sup>2</sup> But clearly, this is the direction we must head to ensure availability of the wide bandwidth pipes required to transfer tomorrow’s very high data rates. The Air Force and DOD must fully support and exploit this technology development which brings “in-time” information into the cockpits of aircraft, remote cockpits of UAVs, consoles of ships, dashboards of land vehicles, and troops on the ground, and then automatically updates the information in a moving digital situational awareness display.

Desert Shield/Storm stressed the military’s current communications capability beyond its capacity, even with the use of all available commercial mobile terminals<sup>3</sup> and commercially procured circuits. These circuits provided connectivity for “common user” requirements as well as specialized data bases for the core automated maintenance system, the standard base supply system, and other “support-type” systems. Communications connectivity for these systems used large fixed and mobile satellite ground stations. From there, much of the data went through an analysis process before being forwarded to the pilot or soldier who needed it. This somewhat lengthy process was not totally responsive to the war fighter or his support elements.

These connectivity and analysis functions were not designed to provide in-time reconnaissance and surveillance data to individual aircraft or soldiers. The delays in relaying information to those who needed it were unacceptable. Capt Scott O’Grady’s shootdown was an example of this phenomenon. Even though system assets had identified and reported the SA-6 threat prior to the actual shootdown, the in-theater assets

at the time could not pass this information to Captain O'Grady in time to affect a different outcome.<sup>4</sup> Improvements to support the war fighter are being made. The joint tactical information distribution system (JTIDS) and the multifunctional information system (MIDS), using the joint-service common datalink (link 16), will give individual pilots a "multisensor" picture of the battlefield by providing access to various sensor platforms.<sup>5</sup> However, with I<sup>3</sup>S we see a capability far beyond that provided by link 16.

In order to support the "in-time" requirements of the future, technology will have to provide computers operating in the tera-bit range, communications paths with the wider bandwidths needed to support this computer power, smaller aircraft antennas, and pocket-sized transceivers. These systems, to be mounted in aircraft and ships and carried by soldiers on the ground, will be fundamental to passing the in-time information (to include data, imagery, targets, coordinates and, status) required by our various forces. As an example of the data capability to be required, passing ultra-high-definition TV pictures will require a data rate of 100 Mbps because of its high resolution.<sup>6</sup> Most users won't have a requirement for this level of detail, but it must be available for those that will. Communications networks will require "smart" automated management systems that can recognize their customers, perform security checks on authorized access levels, and know the nodes to connect to in order to retrieve the requested data--while at the same time, serving a multitude of other customers.

To satisfy the demand for information in the future, we will need seamless fusion and integration of broadband, multimedia networks for the movement of enormous amounts of information to our forces at very high data rates. Advances in data compression techniques will continue to steadily improve bandwidth efficiency.<sup>7</sup> Networks using

asynchronous transfer mode (ATM) technology are expected to be operating in the 2.5 Gbps range, or even higher in the future.<sup>8</sup> ATM builds a transport cell of a fixed size. These cells are made up of data and digitized video and voice information that is grouped together for transmission. Processing cells of a fixed size allows the network to operate at higher speeds and with greatly improved efficiency. Consider the standard lanes of a highway in a major metro area during rush hour. The lanes are packed with vehicles of various sizes, personal vehicles with one or more passengers, small and large commercial trucks, and motorcycles, all in stop-and-go traffic. Now, take the people out of the personal vehicles and put them into buses with access to the express lane. The buses are all the same size and can travel at a constant speed, in formation, to the destination. The trip now becomes much faster and more orderly.

Research advances have also been made in using optical technology for ultra-high-speed telecommunications called photonic fast packet switching. “Optical frequency carriers have an almost unlimited bandwidth potential to the 20 Tera-Hertz range!”<sup>9</sup> Commercial fiber optic cables currently pass data in the 2.5 Gbps range--capable of moving a copy of the *Encyclopedia Britannica* from coast-to-coast in a second’s time.<sup>10</sup> This advancing technology will likely overcome a major stumbling block of current electrical interface switching—lack of high speed because of transmission path limitations. Current optical-electrical connections are also an impediment to very-high-speed networks as the data must be slowed to the rate acceptable at the electrical connection. A problem with creating an optical superhighway is multiplexing the data (allows for the transmission of many different users’ data on a single path) and then moving it long distances without having to convert it back to an electrical signal for



amplification along the way. The recent development of the optical amplifier to restore the optical signal over long distances will eliminate this need for optical-electrical connections during transmission.<sup>11</sup> “Optical interconnects . . . consume significantly less electrical power . . . and can provide large numbers of interconnect channels in a small, low weight, rugged subsystem.”<sup>12</sup> It is conceivable that an optical computer could be built through the use of photons instead of electrons.

Satellite systems will continue to play a key and increasing role as we move toward 2025. These systems will provide the primary connectivity to aircraft and will be the only method capable of passing the high data rates that many I<sup>3</sup>S products will require. When the pilot wants to see an up-to-date situational map, a live video feed of his upcoming target area, or the latest BDA on his last target run, I<sup>3</sup>S will generate it and a satellite downlink will deliver it. Satellite systems will also continue to meet the communications needs of customers on the ground and afloat, and on a much grander scale.

Advances in satellite technology are on going and will need to continue if we are to meet 2025 requirements. “Satellites of the future may operate in unconventional orbits, be very ‘intelligent,’ have enormous processing power, and require only supercompact and lightweight optics or electronics.”<sup>13</sup> I<sup>3</sup>S will require many, very small, inexpensive satellites. They will be the heart of our connectivity for airborne assets, deployed forces, and ships at sea where it is impossible or impractical to run fiber optic networks.

The iridium network of 66 small, low-earth orbiting (LEO) satellites, which is expected to be operational in 1998, will provide seamless handheld connectivity anywhere on the planet.<sup>14</sup> These satellites will be capable of passing voice, data, and facsimile transmissions through a pocket-sized transceiver.

In addition to the iridium network, direct broadcast satellites (DBS) have bandwidths of 1 Gbps or more. DBS systems are currently being sold to private users for home reception of television programming normally found on cable TV systems. DoD is developing its version of DBS, to be called the joint broadcast system (JBS). Both DBS and JBS operate in a “receive” mode whereby one (or possibly a few) ground station transmits information to the satellite which then resends it to many receivers. The very high bandwidth of these systems will significantly reduce transmission time of critical data. To put this in perspective, an air tasking order (ATO) of 1.1 million bytes would take over an hour to transmit on a standard 2.4 kbps UHF circuit but only 0.38th of a second on a 23 Mbps JBS system! An annotated 8 X 10 imagery of 24 million bytes would take 22.2 hours at 2.4 kbps but only 8.4 seconds on JBS. The complete Desert Storm log support Time-phased force and deployment data (TPFDD) (250 million bytes) would take 9.65 days to transmit at 2.4 kbps but only 1.45 minutes on JBS.<sup>15</sup> This is the magnitude of the quantum leap in transmission capability required to ensure that all forms of “in-time” information can get to where it is needed, when it is needed. The Air Force, as the executive agent for JBS, will play the leadership role in bringing this technology to DoD. The next generation of JBS, and the one that I<sup>3</sup>S will need by 2025, must have full two-way (send/receive) transmission capability from one user to another anywhere in the world, and it must be capable of serving many users simultaneously.

## Computers

Similar advancements are being made in the arena of computing power. The 1975 Apple-1 computer had the same computing power as the 1960 IBM-7090 mainframe costing \$5M. A Pentium computer that cost \$5K in 1994 had the computing power of a near priceless 1975 Cray-1 Supercomputer. Analysts predict that in the next few months, INTEL will reduce the price of one of its Pentium microprocessor chip lines by 65 percent.<sup>16</sup> This trend is expected to continue with available computing power doubling every 18 - 24 months (as it has for the last three decades) and chip prices continuing to fall. According to David A. Patterson, a professor of Computer Science at the University of California, Berkley, on-chip memory capacity has grown by a factor of four every three years, but memory speed has not kept pace-- and the gap keeps widening.<sup>17</sup> In the **New World Vistas** "Information Applications Panel" volume, Drs. Harold W. Sorenson and Ronald D. Haggerty are of the opinion that memory and storage devices are keeping pace with chip development.<sup>18</sup> Regardless of this difference of thought, advances are being made in memory technology--and these advances must continue if we are to meet the challenges of faster computers and broadband data networks. For the future, Mr Patterson proposes that processors and memory be merged on the same chip to keep processor speed and memory capacity at the same rate of development.<sup>19</sup>

A current capability we lack because of the computer and sensor technology required is the ability to fingerprint a specific item, whether it be tank, truck, or aircraft, and then, based on that fingerprint, know at any given instant where that item is. This concept would identify enemy resources with a laser imprint that can later be detected by sensor systems, similar to a vehicle identification number. This capability would have

brought welcomed relief in Desert Storm as we tried to locate SCUD launchers before they had a chance to fire their rockets. The fingerprinting technology is being researched and will be discussed in the sensor section. The computing power required to keep track of all this information is massive—but the requisite technology is on the way. “At that rate (of microprocessor development), a factor of 1,000 increase in rate would only take about 20 years, so that a capability to detect and track trucks, tanks, and planes from space could become available as early as 2015.”<sup>20</sup> Therefore, an important part of the information to be available in I<sup>3</sup>S is already envisioned to occur ten years before 2025.

“The Advanced Research Projects Agency (ARPA) is sponsoring the development of a massive parallel computer capable of operating at a rate of one trillion floating point operations per second (1 tera FLOPS).”<sup>21</sup> Improvements in data storage and retrieval will come from “advances in . . . such media as holography and optical storage . . . an optical tape recorder capable of recording and storing more than a terabyte of data on a single reel is being explored . . . vertical line block (VBL) chips could achieve (volumetric) storage densities ranging from one gigabit to one terabit per cubic centimeter. Chip data rates, a function of chip architecture, can range from one megabit/second to 100 megabits/second.”<sup>22</sup> This increase will enable creation of an archival database to store the vast amounts of raw data required by the I<sup>3</sup>S to support users.

A number of new computing concepts are on the horizon. In an article in *Science* magazine, James Glanz outlines five developing technologies.<sup>23</sup>

1. *Quantum dots* which trap individual electrons in semiconductor material so small that the electron wave in the dot is driven to take on a specific energy state.

Processing speed increases on the order of 100 to 10,000 are anticipated, but current developments require stabilized low temperatures in which to operate.

2. *Quantum computer technology* is based on the belief that the wave of a single electron has the capability to take on many different states at once. The individual states hold a specific piece of data and could be run concurrently on a parallel processor. Speed increases of a trillion or more show up in the most optimistic theories. These computers are only anticipated to be able to solve problems dealing with exponential accumulation of error-type problems.

3. Holographic Association works on a *nonlinear process* that allows “information in one light beam to affect how the material ‘processes’ a second beam. In effect, the medium performs many computations in parallel.”<sup>24</sup> Speed increases on the order of 100,000 may be available. This process will likely find a home in pattern recognition and artificial intelligence, two of the things that our I<sup>3</sup>S processor will have to master.

4. *Optical computers* will process via light instead of electrons. Processing by using pulses of light, rather than electrons, can significantly increase speed. Basic speed increases may be as high as 100,000, and could be further increased with additional parallel processing. Other optical components will also have to be developed or improved to enable this technology.

5. *DNA computers* will use “up to  $2^{70}$  DNA molecules. . .[to] act as individual processors.”<sup>25</sup> DNA processing, if perfected, will allow the capability of processing billions of operations simultaneously.<sup>26</sup> Richard Lipton, a Princeton computer scientist, has developed a DNA algorithm for cracking the digital

encryption standard.<sup>27</sup> Although it is currently a lengthy process, it shows the significant processing power anticipated in computers of the future. Speed increases of a trillion are being talked about, but this technology is in its infancy. It appears the computer and connectivity capabilities that I<sup>3</sup>S will require will be there. We need to come to grips on how to harness them to best meet our military requirements.

Virtual reality will use the power of these advanced computers to generate artificial situations that can be explored, “touched,” and modified. DOD plans to have a working holodeck<sup>28</sup> by the year 2020. These artificial environments will feature all of the human senses allowing the user to become immersed in the scenario. Improvements in this technology will be incremental as we provide high-resolution synthetic environments from virtually any place.<sup>29</sup> “The important thing about virtual reality is . . . [that] it permits people to behave as if they were someplace they are not.”<sup>30</sup> United States Special Operations Forces will be able to use this technology to quickly and accurately assemble a computer mock-up of any area in the world where they may have to make a forced entry or rescue mission.<sup>31</sup> The Air Force will likely train pilots in a 3-D virtual reality simulator, complete with audio that mimics their current surroundings.<sup>32</sup> There is probably no better way to train than with a realistic view of the current situation. Imagine, through the use of advanced group software technologies and virtual reality, a “‘virtual Pentagon’ a destination in cyberspace accessible by Air Force personnel from wherever they happen to be on the planet.”<sup>33</sup>

Neural networks in the computers of 2025 will accurately mimic many of the human brain’s processing capabilities. Expert systems will use human knowledge embedded in a computer to solve problems usually thought to need human intervention.<sup>34</sup>

Together, these capabilities will allow computers to fuse the vast amounts of data required to provide, at a moments notice, the specific information required by a joint forces air component commander (JFACC), other military fighter or a commercial customer. Neural networks must overcome the computer's current limitations in speech and feature recognition, interpreting trends, and learning from experience.

Telepresence models will allow humans to perform functions from remote locations as if they were at the location of the function being performed. For instance, telepresence models will allow for "remote surgery. . . giving the surgeon consistent, natural, sensory-rich accessibility. Manipulation of micron-sized objects with synthetic haptic<sup>35</sup> feedback" will make this possible.<sup>36</sup>

Intelligent software agents, once developed, will greatly aid this process. "An "intelligent agent" is a robust software program that communicates with other entities to gather information and make decisions."<sup>37</sup> Agent programs will have a sense of themselves as independent entities. An ideal agent will know its goal and will work diligently to accomplish it. Some of the tasks intelligent agents will be able to perform include deciding where to acquire requested information from I<sup>3</sup>S, working with other nodes to solve complex problems, performing the fusion function for the vast amounts of data in I<sup>3</sup>S, and protecting the I<sup>3</sup>S resources from unauthorized intrusions. *New World Vistas* "Information Technology" volume lists five motivators for using intelligent software agents:<sup>38</sup>

1. The quantity of information [in 2025] will be too vast and its quality too uneven for most humans to suffer through.
2. Data and database [proliferation will] demand a variety of translators.

3. Stored media will have increasing dimensionality in a variety of formats.
4. The need for improved human—computer interaction.

## **Sensors**

Sensor technology will grow at the same pace as computer technology and will be highly dependent upon it. New combinations of sensors, including those mating optical and radio frequency (RF) bands and others that use data from a large number of spectral bands, are the trends of the future.<sup>39</sup> Smaller reconnaissance satellites will provide more real-time broad-area coverage with extremely high resolution. Downlink bandwidths will be expanded to support increasing in-time capability and requirements. Various countries will likely join together to build new satellite sensor systems, reducing costs, to each, providing an expanded capability, and sharing the intelligence. According to former US Air Force Secretary Edward C. Aldridge, Jr., “The goal is to coordinate international military/civilian space assets to provide a real-time ‘global awareness’ of crisis areas.”<sup>40</sup>

In 2025 you may likely find long-dwell imagers (LDI) replacing our periodic aircraft or low earth orbiting systems. Existing constellations of specialized microsats, or fleets of on-demand microsats which can be injected into orbit as requirements or situations dictate, are part of normal operations in 2025.

Other examples of futuristic sensor system technologies include, but are not limited to these four:

1. A capability to build moving devices onto microchips.<sup>41</sup> This microelectromechanical system (MEMS) chip will combine mechanical functions with electrical functions.<sup>42</sup> This moving mechanism may become an optical mirror,



such as that employed in Fourier Transform Spectrometers. These spectrometers yield high-resolution wavelength discrimination (hyper-spectral) sensors that not only look at factories/refineries and measure activity, but also spectrally resolve what is being manufactured and the origin of the raw materials.

2. High-resolution, day/night, all-weather imagery will be provided by clusters of microsats acting as a synthetic antenna for millimeter, radar-like, resolution. Through real-time processing of the phased history data from multiple clusters, 3-D imagery will be routinely available while small, visual 3-D displays will become commonplace in the field at all levels of service.

3. Collecting and processing the radiation wave fronts from “EMP-like” generators focused on buildings, hangars, or other structures, provides a giant x-ray effect for locating insurgent/terrorist groups or blueprinting structures for potential targeting. This could even be used in the civil sector to x-ray buildings and bridges to determine whether or not they are structurally sound or identify weaknesses following natural disasters. This information could also be exploited by the military against enemy structures.

4. ELINT will routinely provide 24-hour surveillance of threats as well as blue forces. When interrogated with a special code, a chip embedded on our forces will transmit a low probability of intercept (LPI) signal not only providing their GPS coordinates but also a mini-status report. This mini-status report may contain human vital signs, how much fuel is in a vehicle, the amount of ammunition remaining, and so forth. This kind of information overlaid with current imagery and OP-ELINT information will be available directly into the cockpit for pilots,

remote cockpits of UAV drivers, consoles of ships, dashboards of land vehicles, and automatically updated in a moving digital situational awareness display.

The Air Force publication, *New World Vistas: Air and Space Power for the 21st Century*, “Sensors Volume,” also outlines seven illustrative sensor system concepts of things we can expect in the future.<sup>43</sup>

1. *Target reporter* that will provide persistent battlefield surveillance using a long-endurance UAV. A concept for an over-the-water, ultra-endurance UAV is found in Air Force Project 2025 Concept Number 900438, ultra-endurance high-altitude ocean loitering uninhabited reconnaissance vehicle.
2. *Integrated arrays of distributed unattended ground sensors* that will use small devices equipped with multiple microsensors to monitor ground activity and relay information to overhead platforms.
3. *Underground target surveillance* to monitor underground activities dealing with NBC weapons, leadership hubs, etc.
4. *All-condition concealed target detection*, having the ability to detect targets in camouflage and foliage will exploit many sensors.
5. *Weather surveillance and prediction* will make broad-area and local military-unique weather available to war fighters. See the Air Force 2025 White Paper, “Weather Modifications,” for more information on future weather capabilities. Also, Air Force Project 2025 Concept number 900502 proposes putting meteorological sensors on aircraft for continuous real-time data.
6. *Modular, integrated, multifunction phased array-based electro-optical system* will provide multiaperture defensive and offensive operations processing.

7. *Low-cost space-based surveillance* will be orbited on small, launch-on-demand satellites. This concept is a main theme for the success of I<sup>3</sup>S. Air Force 2025 project number 900518 proposes electronic grid throwaway sensors to provide small, economical, disposable sensors that the Air Force could use to seed the battle area for reconnaissance.

More information on these future sensor concepts can be found in the **New World Vistas**, “Sensors” volume. It also outlines seven representative operational tasks and the required enabling technologies for future sensors.

### Notes

1. USAF Scientific Advisory Board, *New World Vistas: Air and Space Power for the 21<sup>st</sup> Century* (unpublished draft, the information technology volume, 15 December 1995), 105.

2. Robert K. Heldman, *Future Telecommunications: Information Applications, Services, and Infrastructure* (New York: McGraw-Hill, 1993), 153.

3. Capt Dave McKenzie, “Comfy Storm Communications,” in *The Desert Shield, Desert Storm Comm Story*, ed. Col Randy Witt (Riyadh, Saudi Arabia: Headquarters USAF Central Command Air Forces, March 1991), 72.

4. Col Gary Armistead, Surveillance and Reconnaissance Requirements Division, interview with Major Adair, HQ USAF/XORR, Washington D.C..

5. Edward J. Walsh, “An Emphasis on Core Competencies,” *SeaPower*. (April 1995) 43–50.

6. Smubhash Nigam, “ISDN and ATM: The Odd Couple,” *Telephony* (4 September 1995), 26.

7. *New World Vistas*, (unpublished draft, the information technology volume), 16.

8. Nigam, 26.

9. *Ibid.*, 26.

10. Vincent W.S. Chan, “All-Optical Networks,” *Scientific American*, September 1995, 56.

11. *Ibid.*, 56.

12. “Leveraging the Infosphere: Surveillance and Reconnaissance in 2020,” *SPACECAST 2020 Report* (Maxwell AFB, Ala.: Air University [Draft], B-20.

13. Joseph N. Pelton, "New Satellite Designs: Leosats to Spidersats," *Satellite Communications*, September 1991.
14. Robert W. Kinzie, "Welcome to IRIDIUM TODAY," *IRIDIUM TODAY* 1, no. 1 (Fall 1994): 3.
15. Maj Steve Spano, "Information Warfare," address at the Air Command and Staff College, Maxwell AFB, Ala., January 1996.
16. Bill Husted, "How Low Can They Go? Steep Cuts in the Cost of PCs by Year-end," *Atlanta Journal-Constitution*, 2 February 1995, F-1.
17. David A. Patterson, "Microprocessors in 2020," *Scientific American*, (September 1995), 49.
18. Harold W. Sorenson and Ronald C. Hagerty, "Coordinating, Planning, and Execution in an Information Rich World," *New World Vistas*, (unpublished draft, the information applications volume), 67.
19. Patterson, 50.
20. "LEVERAGING THE INFOSPHERE, Surveillance and Reconnaissance in 2020," B-5.
21. Ibid., B-20.
22. Ibid.
23. James Glanz, "Computer Scientists Rethink Their Discipline's Foundations," *Science Magazine*, 8 September 1995, 1363.
24. Ibid.
25. Ibid.
26. Robert Pool, "A Boom in Plans for DNA Computing," *Science Magazine*, 28 April 1995, 498.
27. Ibid., 499.
28. Holodeck is a term extracted from the TV Star Trek series referring to a computer generated virtual reality room which allows one to experience the sense of being in any environment, limited only by their imagination.
29. *New World Vistas*, (unpublished draft, the information technology volume), 37.
30. Brenda Laurel, "Virtual Reality," *Scientific American*, September 1995, 70.
31. James Kitfield, "Trading Bullets for Bytes," *Government Executive*, June 1994, 18.
32. Laurel, 70.
33. *New World Vistas*, (unpublished draft, the information technology volume), 101.
34. "Artificial Intelligence and Expert Systems Technology," National Defense University, Information Resources Management College, Emerging Technologies Course, 1994.
35. Haptic is defined as "of or relating to the sense of touch" in the American Heritage Dictionary, 2d College Edition.
36. *New World Vistas*, (unpublished draft, the information technology volume), 37.
37. Sorenson and Hagerty, 76.
38. *New World Vistas*, (unpublished draft, the information technology volume), 39.
39. *New World Vistas*, (unpublished draft, the sensors volume), vi.

40. Craig Covault, "Cooperative Recon Gains Momentum," *Aviation Week & Space Technology*, 9 October 1995, 28.

41 Andrew C. Braunberg and Robert K. Ackerman., "Advanced Research Projects Agency Emphasizes Rapid Development, Use," *Signal Magazine*, December 1995, 21.

42 *New World Vistas*, (unpublished draft, the information technology volume), 24.

43 *New World Vistas*, (unpublished draft, the sensors volume), xiii.

## Chapter 6

### Threats and Countermeasures

Information warfare is defined as any action taken to deny, exploit, corrupt, or destroy the enemy's information and its functions; protecting ourselves against those actions; and exploiting our own military information functions.<sup>1</sup>

The threats to our telecommunications, I<sup>3</sup>S, processors, and sensor systems will only increase as we approach 2025. As technology grows, so does the enemies', terrorists', and computer hackers' ability to invent ways to damage, corrupt, or destroy these systems. The Air Force must ensure that it stays at least one step ahead of these threats. The use of closed systems or those that have a very high degree of protection through the use of cryptographic and to-be-invented security algorithms will be a must. Unbreakable encryption codes will exist as standards throughout the world and will help in this effort.<sup>2</sup> The Air Force's information warfare program will be a key to this success. The Air Force pamphlet "Cornerstones of Information Warfare" lists the activities that comprise information warfare:

1. Psychological Operations—using information to affect the enemy's reasoning.
2. Electronic Warfare—denying accurate information to the enemy [jamming, enemy OPSEC].

3. Military Deception—misleading the enemy about our capabilities or intentions.
4. Physical Destruction—physical attack ranging from conventional bombs to electromagnetic pulse weapons.
5. Security Measures—keeping the enemy from learning about our military capabilities and intentions [and the what, where, why, and how of our C4I operations].
6. Information Attack—directly corrupting the enemy’s information without visibly changing the physical entity within which it resides.

These are also the threats to our systems. We can be sure that our enemies are aware of these types of activities and will try to penetrate our systems while protecting theirs by using them. The Air Force will not be alone in this battle. Many of the companies providing leased commercial service to the Air Force will also be vulnerable. We should work with them to develop security measures that will protect our interests. Perhaps the most powerful fix to these problems is flexibility, with the capability to quickly disseminate a change to the systems software.<sup>3</sup>

## **Security**

Security will focus on protecting I<sup>3</sup>S resources (telecommunications, processors, and sensors) and the access to them. Fail-safe technologies will be established for entering and querying the network. Pilots will be able to press their finger against a visual display screen in the cockpit to sign-on to the I<sup>3</sup>S network. They will have access to any required information, at authorized security levels, for the duration of that mission. The fingerprint impression on the display will initiate sign-on, enable security checks, and verify any other security details. This technology, known as biometric identification, will provide

identifications by means of “physiological traits such as face recognition, finger-, retina-, or voice-print.”<sup>4</sup> Similar systems will be used at ground facilities around the world.

### **Countermeasures**

Countermeasures for deception, intrusion, piracy, and electronic warfare will be critical to ensure the integrity of the information gathered, stored, and provided.

Active and passive systems can overcome jamming, ground station attack, and enemy OPSEC. In the case of jamming, frequency hopping and “hardening” of space links are both effective countering techniques. Hopping rates currently exceed 3,000 hops per second. These rates will most likely continue to increase exponentially in the future, which could make many forms of jamming a minor irritant.<sup>5</sup>

Ground station attack can be prevented by picking locations that offer the most security. For instance, by 2025, Cheyenne Mountain Air Force Base (CMAFB) will be a great place to install the primary I<sup>3</sup>S. Reductions in processor size will significantly shrink the current floor-space requirements of today’s installed systems, freeing up more than enough room for I<sup>3</sup>S. Other secure sites, although probably not as secure as CMAFB, should be developed from currently existing Air Force properties for other I<sup>3</sup>S installations. Protection for sensor and communications satellites can best be ensured through redundancy, using smaller and much less expensive platforms and payloads. There exists a need to achieve a point where it is cheaper to build and launch these systems than it is for the enemy to take them out. The LEOs and microsats discussed earlier are the first step in this direction of small, relatively inexpensive satellites. Security in 2025 will be, as it is today, everyone’s business.



1. Department of the Air Force, *Cornerstones of Information Warfare* (Washington, D.C.: Department of the Air Force), 3.
2. USAF Scientific Advisory Board, *New World Vistas: Air and Space Power for the 21<sup>st</sup> Century* (unpublished draft, the information technology volume, 15 December 1995), 21.
3. *Ibid.*, 74.
4. *Ibid.*, 94.
5. "Leveraging the Infosphere: Surveillance and Reconnaissance in 2020," B-18.

## Chapter 7

### Conclusions/Recommendations

By 2025, telecommunication and dissemination techniques, software technologies, computing power, computer-to-computer interfaces, data compression standards, fuzzy logic, intelligent systems, new dissemination practices, system networks, and human-computer interfaces will be changed in ways that can only be imagined today. These rapidly and continuously advancing technologies will fuel the I<sup>3</sup>S.

The goal of the I<sup>3</sup>S is to create a seamless end-to-end process where dynamic interfaces coexist between and among mission planners, collection resources, producers, users, experts, databases, and weapon platforms. This vision calls for a virtual reality environment where decision makers, war fighters, peacekeepers, policymakers, and/or law enforcers, are connected with tailored, insightful, and actionable intelligence when they need it, where they need it, and how they need it. The intent is to empower participants to push and/or pull data to effect the overall collection, processing, analysis, and dissemination process.

To make this a reality, a broad global network of multilevel connectivities is absolutely critical. The network must connect the proper intelligent nodes with the most experienced and/or knowledgeable people to provide the tools with which to share ideas,

discuss options, brainstorm alternatives, or simply acquire the necessary information in time to be useful.

The key objective is to reduce fog and limit friction for friendly forces while increasing fog and friction for opponents. Sharing knowledge, instincts, and experience will be the ultimate force multiplier as well as the ultimate challenge. Building a sense of “community” to truly obtain top-sight vision will undoubtedly fuel success in achieving information dominance. Success in this area will truly be *revolutionary*.

Considering the increased pace and level of new technological developments, the computing speed and bandwidths required to achieve this top-sight vision are expected to be available by 2025.<sup>1</sup> Meanwhile, budget reductions in the DOD will fuel the continuing shift of new technological development to the commercial sector. Therefore, streamlining and redesigning interfaces across military and civilian sectors will not only drive down overall costs, but will ensure that the DOD remains a key driver in the research and development process.

Taking advantage of commercial opportunities and capabilities will further reduce government research and development costs, thereby freeing financial resources to fund operational security needs and costs for employing and deploying the I<sup>3</sup>S. To ensure optimization and maximize utilization of the I<sup>3</sup>S, a significant paradigm shift in organizational cultures and partnerships must occur.

The shift must knock down stovepipes within and across commercial, government, and military sectors, transforming archaic command and control vertical structures into new lateral and integrated partnerships. “Best practice” ideas and concepts must be

afforded analytic review rather than allowed to become victims of “not invented here” mentalities.

Since cultural change is slow to evolve, the challenge for achieving information dominance must begin today. Accomplishing this monumental task calls for new leadership practices, modern management techniques, and improved education in how organizations and people cooperate, interact, and function. Success in 2025, whether dealing with international trade issues, international crime, terrorism, rouge states, committing forces to a battlefield, or expanding democracy, depends on those who dare to be bold today.

As outlined in this white paper, a number of technologies show promise in meeting the system requirements to make the I<sup>3</sup>S a reality by 2025. Sophisticated enabling technologies will serve to coordinate the vast network of global collection and information assets to deliver the integrated information to the right machine, warrior, weapon, and person in time to be actionable. However, the combination of the I<sup>3</sup>S network and the top-sight vision model<sup>2</sup> of human and machine interface, integrating across key pillars of political, economic, military, and information resources, will provide the most profound insight.

Achieving such high levels of cooperation will call for courageous leadership, perseverance, and focused vision coupled with the skill to balance new technologies and cultural change in education. Cultural change will prove to be the most difficult challenge. As a result, the degree to which leaders and organizations fail to achieve horizontal integration and cooperation across various structures will be directly reflected in the level of information dominance that is achieved in the year 2025.

As participants converge, cooperate, and focus on the end result, true information dominance will accelerate. Too much attention on “cool” technologies at the expense of new cooperative and interactive business practices will result in a less than satisfactory endstate.

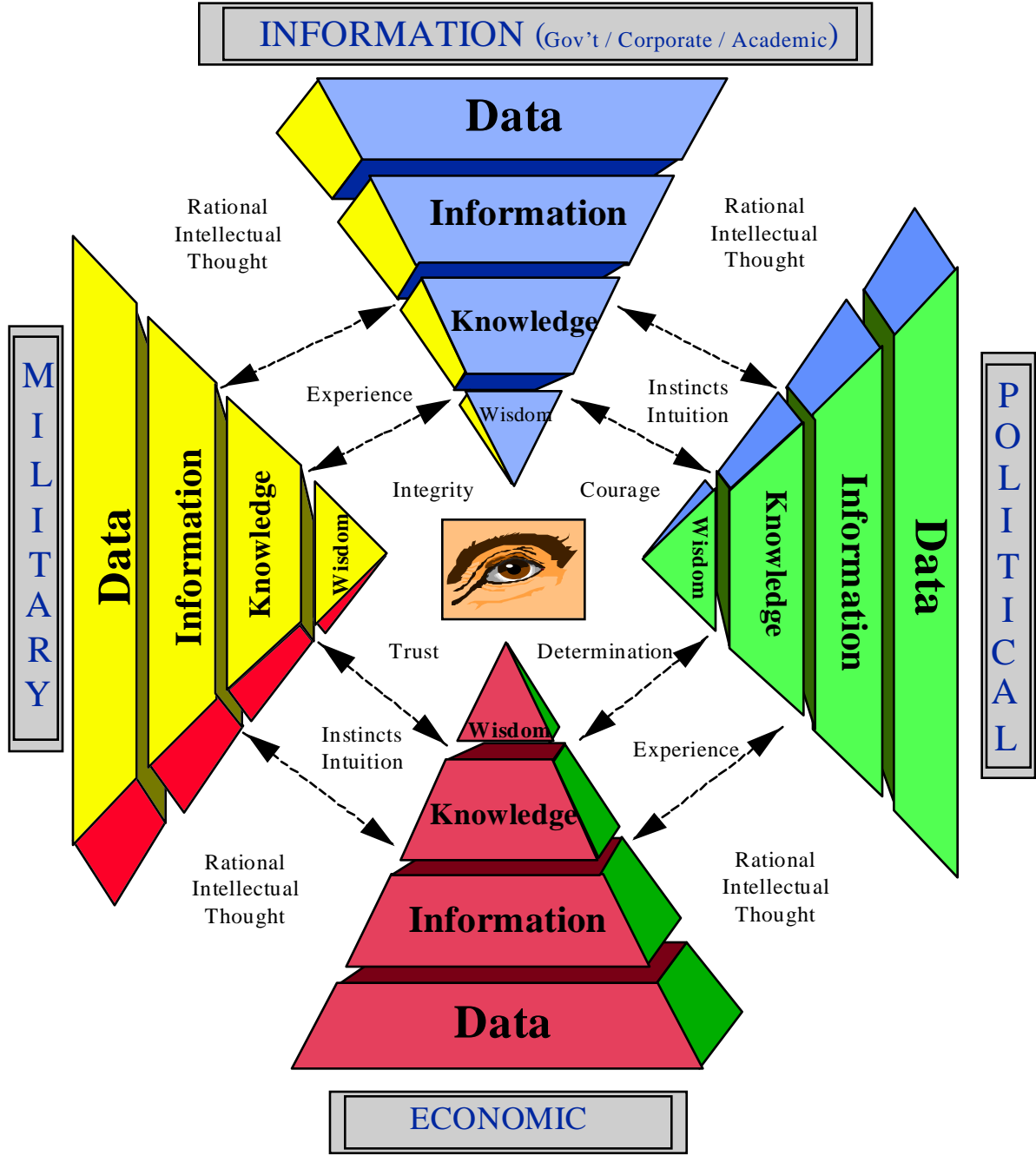
Whether the user is a warrior or a cabinet-level decision maker, the global I<sup>3</sup>S incorporate the key concepts of the top-sight vision model to provide information, knowledge, insight, and wisdom to make success a consistent companion at all levels. The benefits to be realized from this approach are tremendous and will clearly assist America’s military, political, social, and economic superpower status well beyond 2025. Conversely, the consequences of the status quo are just as significant, but far more dangerous. Change, therefore, must begin *now*!

### **Notes**

1. Meeting with **2025** Assessors, Air University, Maxwell AFB, Ala., 26 March 1996.
2. Created by the Authors, Illustrated in Appendix A.

# Appendix A

## TOP-SIGHT VISION MODEL



## *Bibliography*

- 2025** Concept, No. 200059, “Automated & Integrated Intelligence Seamless Fusion & Correlation System,” **2025** Concepts Database, (Maxwell AFB, Ala.: Air War College/**2025**, 1996).
- 2025** Concept, No. 200061, “ Project Safe Journey,” **2025** Concepts Database, (Maxwell AFB, Ala.: Air War College/**2025**, 1996).
- 2025** Concept, No. 200063, “Precision Realtime Targeting System,” **2025** Concepts Database, (Maxwell AFB, Ala.: Air War College/**2025**, 1996).
- 2025** Concept, No. 200064, “Realtime, User-Driven Collection Systems,” **2025** Concepts Database, (Maxwell AFB, Ala.: Air War College/**2025**, 1996).
- 2025** Concept, No. 200065, “Designer Intelligence,” **2025** Concepts Database, (Maxwell AFB, Ala.: Air War College/**2025**, 1996).
- 2025** Concept, No. 900177, “Real-Time Battle Management,” **2025** Concepts Database, (Maxwell AFB, Ala.: Air War College/**2025**, 1996).
- 2025** Concept, No. 900214, “Real-Time Information in the Cockpit (RTIC),” **2025** Concepts Database, (Maxwell AFB, Ala.: Air War College/**2025**, 1996).
- 2025** Concept, No. 900228, “Chameleon Parasite Satellite (CPS),” **2025** Concepts Database, (Maxwell AFB, Ala.: Air War College/**2025**, 1996).
- 2025** Concept, No. 900259, “Airborne/Space-Based Nuclear Materials Sensors,” **2025** Concepts Database, (Maxwell AFB, Ala.: Air War College/**2025**, 1996).
- 2025** Concept, No. 900263, “The All Seeing Warrior,” **2025** Concepts Database, (Maxwell AFB, Ala.: Air War College/**2025**, 1996).
- 2025** Concept, No. 900438, “Ultra-Endurance High-Altitude Ocean Loitering Uninhabited Reconnaissance Vehicle,” **2025** Concepts Database, (Maxwell AFB, Ala.: Air War College/**2025**, 1996).
- 2025** Concept, No. 900502, “Real-Time Weather Observations,” **2025** Concepts Database, (Maxwell AFB, Ala.: Air War College/**2025**, 1996).
- 2025** Concept, No. 900517, “JSTARS Replacement,” **2025** Concepts Database, (Maxwell AFB, Ala.: Air War College/**2025**, 1996).
- 2025** Concept, No. 900518, “Electronic Grid-Throwaway Sensors,” **2025** Concepts Database, (Maxwell AFB, Ala.: Air War College/**2025**, 1996).
- 2025** Concept, No. 900552, “On-Demand Tactical Recce Satellite Constellation,” **2025** Concepts Database, (Maxwell AFB, Ala.: Air War College/**2025**, 1996).

- 2025** Concept, No. 900702, "Implanted Tactical Information Display (ITID)," **2025** Concepts Database, (Maxwell AFB, Ala.: Air War College/**2025**, 1996).
- 2025** Concept, No. 2000023, "Surveillance Swarm," **2025** Concepts Database, (Maxwell AFB, Ala.: Air War College/**2025**, 1996).
- "Artificial Intelligence and Expert Systems Technology." National Defense University, Information Management Resources College, Emerging Technologies Course, 1994.
- Armistead, Col Gary Surveillance and Reconnaissance Requirements Division, interview with Major Adair. HQ USAF/XORR, Washington, D.C.,
- Boorda, Adm Jeremy M. "Leading the Revolution in C<sup>4</sup>I." *Joint Force Quarterly*, no. 9 (Autumn 1995): 14-17.
- Boyd, Col John (USAF, Ret). "Observe-Orient-Decide-Act (OODA) Loop." An address given to **2025** participants. Air University, Maxwell AFB, Ala., October 1995.
- Braunberg, Andrew C. and Ackerman, Robert K. "Advanced Research Projects Agency Emphasizes Rapid Development, Use." *Signal Magazine*, December 1995, 21.
- C<sup>4</sup>I For The Warrior, Global Command and Control Systems, From Concept To Reality.* Washington D.C.: Office of the Joint Chiefs of Staff, J-6 Directorate, 1994.
- Chan, Vincent W.S. "All-Optical Networks." *Scientific American*, September 1995, 56-59.
- Clancy, Tom. *Debt of Honor*. New York: G.P. Putnam and Sons, The Berkley Publishing Group, 1995.
- Cornerstones of Information Warfare.* Washington DC.: Department of the Air Force.
- Covault, Craig. "Cooperative Recon Gains Momentum." *Aviation Week and Space Technology*, 9 October 1995, 28.
- Crownover, Maj Joseph. Air Force TENCAP Project Officer, interview with Major Adair. HQ USAF/XORR, Washington, D.C.,.
- Crute, Dan. "Expeditionary Warfare Data Fusion System for Command and Control." NSWCCSS Concept Paper. (FOUO)
- Feigenbaum, Dr Edward. "Expert Interview." *IEEE EXPERT*, December 1995, 9-11.
- Fogleman, Gen Ronald. An address to **2025** participants. Air University, Maxwell AFB, Ala., 13 February 1996.
- Glanz, James. "Computer Scientists Rethink Their Discipline's Foundation." *Science Magazine*, 8 September 1995, 1363.
- Hazlett, Jim. "Reconnaissance-Strike Defense Complex (RSDC)." SAIC Concept Paper. (FOUO)
- Heldman, Robert K. *Future Telecommunications: Information Applications, Services & Infrastructure*. New York: McGraw-Hill, 1993.
- Husted, Bill. "How Low Can They Go? Steep Cuts in Cost of PCs by Year-end," *Atlanta Journal-Constitution*, 2 February 1995, F-1.



- “IRIDIUM System Overview.” Supplement to *IRIDIUM TODAY* 1, no.1 (Fall 1994).
- “KH-11 Recons Modified.” *Aviation Week & Space Technology*, 9 October 1995, 28.
- Kitfield, James. “Trading Bullets for Bytes.” *Government Executive*, June 1994, 18-25.
- Kinzie, Robert W. “Welcome to IRIDIUM TODAY.” *IRIDIUM TODAY* 1, no.1 (Fall 1994): 3.
- Laurel, Brenda. “Virtual Reality.” *Scientific American*, September 1995, 70.
- “Leveraging the Infosphere: Surveillance and Reconnaissance in 2020.” *SPACECAST 2020 Report*. Maxwell AFB, Ala.: Air University (Draft).
- Luzgin, Tamara. *Tactical Picture Executive Tool*. Naval Research Laboratory Concept Paper. Washington, D.C.
- Mizoguchi, Riichiro and Motoda, Hiroshi. “Expert Systems Research in Japan.” *IEEE EXPERT*, August 1995, 18-23.
- Morefield, Dr Charles L. “Situational Awareness in the 21st Century.” USAF Scientific Advisory Board. *New World Vistas: Air and Space Power for the 21<sup>st</sup> Century*. Unpublished draft, the Information Applications Volume. 15 December 1995.
- Negroponete, Nicholas. *Being Digital*. New York: Vintage Books, 1995.
- Owens, Adm William A. “Four Revolutions in Military Thinking.” *The Officer*, August 1995, 29-32.
- Patterson, David A. “Microprocessors in 2020.” *Scientific American*, September 1995, 48-51.
- Pelton, Joseph N. “New Satellite Designs: Leosats to Spidersats.” *Satellite Communications*, September 1991, 18.
- Pool, Robert. “A Boom in Plans for DNA Computing.” *Science Magazine*, 28 April 1995, 498.
- Sorenson, Harold W. and Hagerty, Ronald D. “Coordinating, Planning, and Execution in the Information-Rich World.” USAF Scientific Advisory Board. *New World Vistas: Air and Space Power for the 21<sup>st</sup> Century*. Unpublished draft, the Information Applications Volume. 15 December 1995.
- Spano, Maj Steve. “Information Warfare.” An address at the Air Command and Staff College, Maxwell AFB, Ala., January 1996.
- Subhash, Nigam. “ISDN and ATM: The Odd Couple.” *Telephony*, 4 September 1995, 26.
- Swedberg, Capt Edward. Chief, LANDSAT System Utility Branch, interview with Major Adair. SAFSP/DLPO, Washington, D.C.
- USAF Scientific Advisory Board. *New World Vistas: Air and Space Power for the 21<sup>st</sup> Century*. Unpublished draft, the Information Technology Volume. 15 December 1995.
- . *New World Vistas: Air and Space Power for the 21<sup>st</sup> Century*. Unpublished draft, the Sensors Volume. 15 December 1995.

- . *New World Vistas: Air and Space Power for the 21<sup>st</sup> Century*, Summary Volume. Washington, D.C.: USAF Scientific Advisory Board, 15 December 1995.
- Walsh, Edward J. “An Emphasis on Core Competencies.” *SeaPower*, April 1995, 43-50.
- Witt, Colonel Randy (editor). *The Desert Shield, Desert Storm Comm Story*. Riyadh, Saudi Arabia: Headquarters United States Central Command Air Forces, 1991.

**The Command or Control Dilemma:  
When Technology and Organizational  
Orientation Collide**



A Research Paper  
Presented To

Air Force *2025*

by

**Gregory A. Roman**  
Lt Col, USAF

**Advisor: Col Victor Budura, Jr.**

**April 1996**

## **Disclaimer**

*2025* is a study designed to comply with a directive from the chief of staff of the Air Force to examine the concepts, capabilities, and technologies the United States will require to remain the dominant air and space force in the future. Presented on 17 June 1996, this report was produced in the Department of Defense school environment of academic freedom and in the interest of advancing concepts related to national defense. The views expressed in this report are those of the authors and do not reflect the official policy or position of the United States Air Force, Department of Defense, or the United States government.

This report contains fictional representations of future situations/scenarios. Any similarities to real people or events, other than those specifically cited, are unintentional and are for purposes of illustration only.

This publication has been reviewed by security and policy review authorities, is unclassified, and is cleared for public release.

## *Contents*

<i>Chapter</i> .....	<i>Page</i>
Disclaimer .....	ii
Illustrations.....	iv
Executive Summary .....	v
Biographical Sketch.....	vi
1 Introduction.....	1
2 A Frame Of Reference .....	4
3 A Historical Perspective.....	8
4 An Organizational Orientation Model.....	15
5 Differing Service Orientations .....	28
6 The Air Force Orientation.....	30
7 Recommendations .....	34
8 Conclusion .....	36
Bibliography.....	38

## Illustrations

<i>Figure</i> .....	<i>Page</i>
4-1. Tempo and Command .....	16
4-2. C <sup>2</sup> Dynamics .....	17
4-3. Technology/Organization/Procedures Impact .....	18
4-4. Shared Information/Decision Process.....	25

Copyright note: All illustrations include clip art by Microsoft except Figure 1. Microsoft Clipart Gallery<sup>®</sup> 1995 with courtesy from Microsoft Corporation, One Microsoft Way, Redmond, Wa.

## *Executive Summary*

In an information-age military, the proper organizational orientation may no longer be one of command and control, but command *or* control. Historically, the military's response to new information technology has always been greater centralized control. Unfortunately, greater centralized control is the exact opposite of what is desired to maximize the benefits of information technology. As the tempo of operations increases, so does the demand for faster decision making. Information technology, however, is creating a faster information- gathering cycle, but not a correspondingly faster decision-making cycle. This creates an imbalance that can only be corrected by the proper organizational orientation which takes full advantage of information. The information-age military needs the shared information-gathering advantages of a networked organization with the decentralized decision-making advantages of a flattened hierarchical organization. Failure to adapt to a new organizational orientation of decentralized control may result in a US military unable to operate at the increased tempo of future warfare.

## ***Biographical Sketch***

Lt Col Gregory A. Roman (BS, US Air Force Academy; MS, Troy State University) is a career intelligence officer. His duty assignments include tours as an operations officer and squadron commander for EC-130 and RC-135 operations. He has been stationed in Greece, Korea, Germany, Panama, and Japan. While assigned to the Pentagon, he served as the tactical cryptologic program element monitor and executive officer to the assistant chief of the Air Force/Intelligence, and on the secretary of the Air Force's legislative liaison staff. He is a distinguished graduate of Squadron Officer School and a graduate of Air Command and Staff College.



# Chapter 1

## Introduction

*The functions of command are eternal.*

—Martin van Creveld, 1985

*Once upon a time, everybody understood what commanders did. They commanded. This was simple enough and sufficient for a thousand years or more . . . now, commanders would exercise command and control.*

—Greg Todd, 1985

*One of the least controversial things that can be said about command and control is that it is controversial, poorly understood, and subject to wildly different interpretation. The term can mean almost everything from military computers to the art of generalship: whatever the user wishes it to mean.*

—Kenneth Moll, 1978

Command and control, words or a phrase very familiar to the military, are subject to much confusion and misinterpretation. What does command and control really mean and is our current command and control orientation the proper one for an information-age military?<sup>1</sup> These are important questions as the US military grapples with the potentially revolutionary changes brought on by modern information technology. If information-age technology is indeed ushering in a revolution in military affairs (RMA), then organizational structures and associated command and control orientation must change. In 1995, the secretary of defense stated:

Historically, an RMA occurs when the incorporation of new technologies into military systems combines with the innovative operational concepts and organizational adaptations<sup>2</sup> to fundamentally alter the character and conduct of military operations.

These organizational changes are occurring in the business world, but can we say the same for the military?

The Air Force Scientific Advisory Board's (SAB) 1995 "New World Vistas" report notes:

Even the most casual glance at business history makes it clear that each time a new information infrastructure becomes available (e.g., railroad, telegraph, telephone) the entities which are ultimately most successful are also the first to reshape their structures in order to gain maximum advantage of the new information conduits. The new networks emerging today are “geodesic,” that is, global, non-hierarchical, and without any central node.<sup>3</sup>

The SAB concludes with the optimistic view that “it is a safe bet that our [military] organizations will follow suit.”<sup>4</sup> However, this may be easier said than done given the historical resistance of military organizations in adapting to new organizational orientations.

The US military services have thus far failed to create the innovative operational concepts and make the organizational adaptations needed for the information age, because we remain rooted in an industrial-age command and control paradigm. As pointed out in the draft “Warfighting Vision 2010”, “technological enhancements may have made ‘control’ an anathema to ‘command’.”<sup>5</sup> This creates a dilemma, as in the information age, the correct orientation may no longer be one of command *and* control, but one of command or control. Centralized control exercised by hierarchical organizations may no longer be possible or desirable in a fast-tempo war.

Failure to address this problem could result in a military not prepared for the operations tempo of information-age warfare. As Maj Gen J. F. C. Fuller points out, “The highest inventive genius must be sought not so much amongst those who invent new weapons as among those who devise new fighting organizations.”<sup>6</sup> However, creating new organizational orientations has never been easy. Brigadier J.P. Kiszely expands Fuller’s view:

Without originality, let alone genius, the new technologies will merely be grafted on to existing organizations and doctrines in a way designed to cause the least inconvenience and least unpleasantness in peacetime. The risks of having operated on this principle in the past are as nothing to the dangers of doing so in the future.<sup>7</sup>

Unfortunately, by viewing the benefits of information technology within the current military command and control orientation, we may use that technology in a manner that is the exact opposite of what is most useful.

The seductive nature of information technology is in stimulating military organizational orientation towards greater centralized control and more rigid hierarchical organizations, instead of the desired orientation of decentralized control and more flexible organizations. Unless we recognize the dangers of succumbing to technological temptation, control functions may take priority over command functions, resulting in a military that is both a less efficient and less effective. While this applies to all US military

services, the command or control dilemma particularly impacts the Air Force's command and control orientation of "centralized control, decentralized execution."

This paper will argue that the corrosive effect of an outdated command and control orientation prevents the American military, particularly the Air Force, from fully applying the benefits of information technology. Future warfare, characterized by faster operations tempo, requires a new orientation based not on "centralized control" but on greater decentralized control and more flexible organizational orientation. To better understand this, we must first examine the definitions of command and control to explain why there is so much confusion and misunderstanding. From a historical perspective, we can show how the military traditionally responds to new information technology by emphasizing greater centralized control and rigid hierarchical organizational structures. Then, through the use of an information-gathering and decision-making model, we can determine why our current military orientation of centralized control and hierarchical organizational structures is exactly the opposite of that desired. Finally, from historical evidence and model analyses, we can draw some recommendations on the correct military organizational orientation for the future.

## Notes

1 In *War and Anti-War*, Alvin and Heidi Toffler (Boston: Little, Brown and Co., 1993), describe the differences between agrarian, industrial, and information-age societies and militaries. While some have criticized this categorization as oversimplified, the Tofflers' writings are influential within the US military.

2 William J. Perry, *Annual Report to the President and the Congress* (Washington, D.C.: Department of Defense, 1995), 107.

3 USAF Scientific Advisory Board, *New World Vistas: Air and Space Power for the 21<sup>st</sup> Century* (unpublished draft, the communications volume, 15 December 1995), 17.

4 Ibid.

5 Joint Warfighting Center, draft *Warfighting Vision 2010* (Ft Monroe, Va: Joint Chiefs of Staff, 1 August 1995), 19.

6 Maj Gen J.F.C. Fuller, *Armament and History* (New York: Charles Scribner and Sons, 1945), 158. Of note, on page 146, Fuller gives a scathing critique of Giulio Douhet's motives by stating, "The secret which Douhet could not grasp was that inventive genius when stirred by the instinct of self-preservation knows no bounds. He was a wonderful salesman, and like many people - a prophet of the ridiculous."

7 Brig J.P. Kiszely, "The Contribution of Originality to Military Success," in *The Science of War*, Brian H. Reid (London: Rutledge, 1993), 44-45.

## Chapter 2

### A Frame Of Reference

Our familiarity with the words command and control may lead one to believe that a problem does not exist. After all, these two words sound like they were meant for each other, so few fully appreciate their separate meanings. This cozy word association also gives the impression of equal weighting, value, and importance. While few would challenge this observation, the truth is that there is no agreement on what command and control really means, though many have made a valiant effort to define the term. In *Command and Control for War and Peace*, Thomas Coakley addresses some of the origins behind these two words. He notes that there is little mention of “control” by the early biographers of the great captains of battle. Control was viewed as an organic function of command. However, the word control appears in literature during World War I and more frequently in World War II, possibly because of the increased automation and sophistication of weapons systems.<sup>1</sup> This led to a belief that one commands people but controls things.<sup>2</sup> For example, we can make this distinction by stating we command the aircrews that, in turn, control nuclear weapons. Another view is that command is strategic and operational, while control is tactical. Analogies have been made with the human nervous system, with the command brain controlling the rest of the body.<sup>3</sup> Others believe is that command is an art while control is more a science. John Boyd wrestles with the differences in describing the epitome of command, which to him means to direct, order, or compel, while control means to regulate, restrain, or hold to a certain standard.<sup>4</sup> Boyd goes on to suggest that “leadership and monitoring” are more accurate and descriptive than are command and control.<sup>5</sup>

However, is this word association healthy? And what happens when certain words fall out of favor? One solution is to invent new word associations.<sup>6</sup> For example, command and control (C<sup>2</sup>) has expanded to

C<sup>3</sup> (communications), C<sup>4</sup> (computers), C<sup>4</sup>I (intelligence), and C<sup>4</sup>I<sup>2</sup> (interoperability). The US Marine Corps is advocating an orientation of “command and coordination” as part of their future war-fighting concept called “Sea Dragon,” while the Air Force is championing an orientation called C<sup>4</sup>ISR (surveillance and reconnaissance).<sup>7</sup> One wonders which word will be added next. Perhaps C<sup>5</sup>I<sup>2</sup> (coordination), or C<sup>6</sup>I<sup>2</sup> (cooperation)? Unfortunately, each new word association that tries to describe new thinking or new technology does so at the expense of the most important word command, or what Greg Todd calls “C<sub>1</sub>.”<sup>8</sup>

The Joint Chiefs of Staff (JCS) does not provide much help in clarifying the confusion over the term “command and control.” JCS Pub 0-2 defines command as

the authority that a commander in the Military Service lawfully exercises over subordinates by virtue of rank or assignment. Command includes the authority and responsibility for effectively using available resources and for planning the employment of, organizing, directing, coordinating, and *controlling* military forces for the accomplishment of assigned missions. (Emphasis added)<sup>9</sup>

By definition then, control is a component of command. Why then do we distinguish control from command, and why give preferential treatment to the notion of control but not to those of organizing, directing, or coordinating? Perhaps it is because we fail to see the difference. There are many obvious similarities when comparing command with the JCS definition of command and control as

the exercise of authority *and direction* by a designated commander over assigned and attached forces in the accomplishment of the mission. *Command and control functions are performed through an arrangement of personnel, equipment, communications, facilities, and procedures employed by a commander in planning, directing, coordinating, and controlling forces and operations in the accomplishment of the mission.* (Emphasis added)<sup>10</sup>

The differences between these two definitions are italicized above. The latter describes the orientation (which will be discussed later) through which a commander exercises command and control. For now, let us focus on the italicized word “direction.” Does this imply control? If so, then one would logically expect the JCS definition of control to be “the exercise of direction by a properly designated commander over assigned and attached forces in the accomplishment of the mission.”

This would make sense in explaining that command is the exercise of authority while control is the exercise of direction. However, things are not this easy. Control is also exercised by civilian leadership, such as President Kennedy’s executive committee handling the Cuban Missile Crisis; or by military personnel, like air traffic or weapons controllers, as part of their official duties. Thus, control also applies to people in noncommand functions.

The JCS definition of control does little to clear up the confusion by describing it as

authority which may be less than full command exercised by a commander over part of the activities of subordinate or other organizations.<sup>11</sup>

JCS definitions, do little to clarify the command or control definition dilemma. Is command defined by “authority for full command exercised by a commander?” control is defined as “authority of less than full command exercised by a commander?” If so, what exactly does that mean? It would appear that more accurate, unambiguous, and descriptive definitions are the first step in resolving the command *or* control dilemma.

Perhaps what is needed is a fresher and simpler perspective. The JCS definition of command already asserts that command contains all the essential ingredients necessary for accomplishing the assigned mission. As Todd points out, “If atoms could be split, so could the act of command. Now, commanders would exercise command and control. Eureka! Never mind that command already implied control. Never mind that without control one could not command.”<sup>12</sup> By recalling Van Creveld’s statement about “the eternal nature of command,” we have only ourselves to blame in confusing the issue and making it more complex than it has to be. JCS Joint Pub 1 reminds us that, “The primary emphasis in command relations should be to keep the chain of command short and simple so that it is clear who is in charge of what.”<sup>13</sup> Command, by its very eternal nature, provides that simple orientation that stands the test of time and introduction of new technology.

## Notes

1 Thomas P. Coakley, *Command and Control for War and Peace* (Washington, D.C.: National Defense University Press, 1992), 36.

2 Ibid.

3 Ibid., 41–42; and Martin van Creveld, *Command in War* (Cambridge, Mass.: Harvard University Press, 1985), 263.

4 John R. Boyd, “Organic Design for Command and Control” (August 1987), excerpt from “A Discourse on Winning and Losing”, a selection of unpublished briefings and essays (Air University Library, document M-h 30352-16no7791), 2..

5 Ibid.

6 This word association may be more psychological than practical. My thanks to Lt Col Chancel T. French (retired) for educating me on a possibility of our habit of word association having historical origins dating to the Battle of Hastings in 1066. One outcome was the mingling of English, French, and Latin words on legal documents and in everyday usage. As a result, word associations like cease and desist, to have and to hold, search and destroy, and command and control are now common jargon. My thanks also to Col Dick

Szafranski for explaining the Russian usage of “duty terms” when talking about certain military subjects. Command and control is a duty term.

7 Provided by US Marine Corps and US Air Force briefers during the Air War College academic year 1995–1996. Used with permission.

8 Greg Todd, “C<sub>1</sub> Catharsis”, *Army* (Carlisle Barracks, Pa.: Army War College, February 1986), 14.

9 Joint Pub 0-2, *Unified Action Armed Forces* (Washington, D.C.: Joint Chiefs of Staff, 24 February 1995), GL-4.

10 *Ibid.*, GL-4 and 5.

11 Joint Pub 6-0, *Doctrine for Command, Control, Communications, and Computer (C4) Systems Support* (Washington, D.C.: Joint Chiefs of Staff, 30 May 1995), GL-6.

12 Todd, 14.

13 Joint Pub 1, *Joint Warfare of the Armed Forces of the United States* (Washington, D.C.: Joint Chiefs of Staff, 10 January 1995), III-9.

## Chapter 3

### A Historical Perspective

Throughout the history of warfare, commanders have had to address two fundamental questions. As Frank Snyder points out, one question is, “What is actually happening?” and the second is, “What can I or should I do about it?”<sup>1</sup> The former question involves a process of information gathering, while the second is the process of decision making. These two processes are critical when studying the evolution of military orientation towards greater centralized control and hierarchical organizations.

Perhaps the only time command and control was not an issue was when warfare involved single command and low technology. In preindustrial-age warfare prior to the mid-1700s, commanders personally gathered information and decided on courses of action. So critical was the commander that a recognized tactic in defeating an enemy army was in capturing or killing the enemy commander.<sup>2</sup> One of the greatest of these preindustrial-age commanders was Alexander the Great, whose command John Keegan describes as one of strong, centralized control. He commanded alone, as the need for a general staff or subordinate commanders was not deemed necessary.<sup>3</sup> Alexander’s armies numbered no more than 50,000, but were usually smaller.<sup>4</sup> His preparation for battle was based on his own observations, knowledge of the enemy, awareness of his own capabilities, his experiences in previous battles, and his genius in formulating battle plans.<sup>5</sup> To gather information, he usually selected a high point to observe both the enemy and his own troops. Once a decision was made, Alexander issued orders by word of mouth directly to his troops. Prior to one battle, he used a platform to address his army; at another he rode along the entire front of his force of 50,000 men and stopped every so often to repeat his speech, thus allowing the information to be relayed to the rear of the formation.<sup>6</sup>



However, single command also was limited by how much one leader could do. As his record of eight war wounds would attest, once battle was engaged, Alexander would lead the charge, losing the ability to gather information or make decisions except in his immediate vicinity.<sup>7</sup> In preindustrial-age warfare, command orientation was simple with few technological wonders for controlling large armies. As James Coyne notes in his study of airpower in the Gulf War:

Before the age of electronics and aerospace technology, command and control—in the modern sense of the term—was a comparatively minor element in warfare. Battles were fought, albeit inefficiently and often ineffectively, independent of the health of supporting communications.<sup>8</sup>

The key factor in controlling armies was not technology but rather the commanders' personal capacity to command.

This changed, however, as the industrial age, starting in the mid 1700s, introduced technology and innovations that made control of larger armies possible. The response to this technology was greater centralized control exercised by hierarchical organizations. The Prussian military was one of the first to cope with this increased span of control by introducing innovations such as the general staff and a hierarchical command structure. Both these innovations dramatically affected the commander's information-gathering and decision-making process.

With larger armies spread over greater distances, the industrial-age commander required others to help him gather information and implement decisions. For example, Frederick the Great, unlike previous commanders, remained at a fixed headquarters behind his troops, where he gathered information and made decisions.<sup>9</sup> Without personal involvement in the information-gathering process, he relied more and more on information provided by his staff and subordinate commanders. By having others helping decide "what is going on," the industrial-age commander became much more susceptible to what Clausewitz describes as the "realm of uncertainty."<sup>10</sup> The obvious response to increased uncertainty was greater centralized control.

Napoléon continued the tradition of centralized control. John Boyd believes that Napoléon, influenced by the writings of Clausewitz and Henshi de Jomini, viewed the conduct of war as essentially one directional, from the top down, emphasizing adaptability at the top and regularity at the bottom.<sup>11</sup> While Napoléon probably believed that his military genius did not require subordinate commanders to be burdened with making decisions, he understood that his hierarchical command structure hampered his information gathering

needs. To cope with uncertainty, Van Creveld describes Napoléon's creative use of aides-de-camp as a "directed telescope" to gather information independently of his general staff and commanders.<sup>12</sup> However, despite Napoléon's many creative innovations, his command and control orientation had limits.

In particular, Napoléon's centralized control orientation could not overcome the complexity, size, and tempo of modern, industrial-age warfare. As Van Creveld correctly points out;

The paradox is that, though nothing is more important than unit of command, it is impossible for one man to know everything. The larger and more complex the forces that he commands, the more true this becomes.<sup>13</sup>

While Napoléon commanded 85,000 men at Austerlitz with great success, he lost control of half his force of 150,000 men at Jena and had no control of his 180,000-man force at Leipzig.<sup>14</sup> Boyd believes that Napoléon's eventual downfall was attributable to his highly centralized command and control system. His orientation created unimaginative, formalized, and predictable actions at lower levels of command and "minimized the possibility of exploiting ambiguity, deception, and mobility to generate surprise for a decisive edge."<sup>15</sup> Possible solutions were either a new organizational orientation or a new technological breakthrough; not surprisingly, the technological breakthrough came first.

The major technological innovations of industrial age warfare in the mid-1800s were the railroad and the telegraph. The railroad increased the mobility of larger armies, while the corresponding introduction of the telegraph allowed for greater control of armies over larger distances. Commanders responded to this communications technology by increasing control at the top. However, this technology became a double-edged sword. While increasingly demanding more information from subordinate commanders, senior commanders had to respond to more information requests from their superiors. As an Austrian officer wrote in 1861, "A commander who is tied down in this way is really to be pitied; he has two enemies to defeat, one in the front and one in the rear."<sup>16</sup> History notes that Napoléon III was communicating from Paris and often harassing his generals in Russia about progress in the Crimean War.<sup>17</sup> Col S. L. A. Marshall describes a World War II phenomenon in which company commanders joined a platoon on the front lines just to isolate themselves from the telephone, because "they were literally 'tired to death,' having the battalion commander insist on having a fresh progress report every fifteen or twenty minutes."<sup>18</sup> Thus, information technology proved very seductive in providing the means for greater centralized control.

The need to balance legitimate requests for information while allowing subordinate commanders the freedom of action is a difficult one. Prussian leader Helmuth Karl Bernhard von Moltke “the Elder” was one of the first to appreciate the value of the telegraph, but he also recognized the increased tendency in using it to find out what was happening at the front.<sup>19</sup> In his *Thoughts on Command*, Von Moltke writes:

The most unfortunate of all supreme commanders is the one who is under close supervision, who has to give an account of his plans and intentions every hour of every day. This supervision may be exercised through a delegate of the highest authority at his headquarters or *a telegraph wire attached to his back*. In such a case all independence, *rapid decision*, and audacious risk, without which no war can be conducted, *ceases*.  
(Emphasis added)<sup>20</sup>

General George Patton, reflecting in his *Diaries* about World War II, complained frequently about being tied to the radio and telephone, noting, “The hardest thing I have to do is to do nothing. There is a terrible temptation to interfere.”<sup>21</sup> And frequently, this temptation became too great to ignore, as Maj Gen J. F. C. Fuller explains from his World War I experience.

The General became more and more bound to his office, and, consequently divorced from his men. He relied for contact not upon the personal factor, but upon the mechanical telegraph and telephone. They could establish contact, but they could accomplish this only by dragging subordinate commanders out of the firing line that they may be at the beck and call of their superiors. In the World War, nothing was more dreadful to witness than a chain of men starting with a commander and ending with an army commander sitting in telephone boxes, improvised or actual, talking, talking, in place of leading, leading, leading.<sup>22</sup>

In many instances, commanders relied on information technology to help them navigate the “realm of uncertainty”. How commanders dealt with uncertainty determined the level of control and the organizational orientation.

Organizational orientation determines the degree of uncertainty a commander is willing to tolerate. Van Creveld declares that the history of warfare is an endless quest to decrease the realm of uncertainty, resulting in a race between more information and the ability of technology to keep up with it.<sup>23</sup> Thus, the choice between centralized or decentralized control involves the distribution of uncertainty. Van Creveld believes that while centralization reduces uncertainty at the top, it increases that uncertainty at the bottom. Decentralization has just the opposite effect.<sup>24</sup> It is human nature for higher-level commanders to reduce their uncertainty, driving their organizational orientation to greater centralized control. Thus, the cost for less

uncertainty at the top is more uncertainty at the bottom. The cost for greater control at the top is less autonomy in the field.

Unfortunately, the greater the level of control, the fewer opportunities for initiative and flexibility where it is most needed to cope with the dynamics of warfare: at the lower levels of command. Frank Snyder points out that prior to reliable long-distance communications, commanders wrote orders with objectives at a level high enough to give lower-level commanders the flexibility to adjust their actions according to current events.<sup>25</sup> Commanders expected that communications would be unreliable and planned accordingly. This is no longer as true today because information technology is making communications more available and more reliable. For example, the number of radio sets rose from one for every 38.6 soldiers during World War II to one for every 4.5 soldiers in Vietnam.<sup>26</sup> This is an increase of almost 900 percent. Moreover, communications are more reliable. During Operation Desert Storm, the communications reliability rate was 98 percent in handling 700,000 telephone calls and 700,000 messages per day and managing over 30,000 radio frequencies.<sup>27</sup>

Information technology increases the temptation for higher-level commanders to involve themselves with lower-level decisions. For instance, the widespread use of radios in Vietnam allowed commanders hovering above the battles in helicopters to direct soldiers by radio. While deemed effective in directing the battle, the “squad leader in the sky” stifled decision making in the lower ranks.<sup>28</sup> This top-down direction and involvement by senior commanders at the tactical level became known as “skip echelon” battle management and created great resentment among the junior officers in the field when their decisions were overridden.<sup>29</sup> Better information technology increased the skip echelon phenomenon. For example, the commander-in-chief’s ability to talk directly with combat troops during the Mayaguez Incident in 1975 and during Operation Eagle Claw--the aborted rescue mission in Iran in 1980--dramatically changed the command and control orientation.<sup>30</sup> Information technology provides the means for controlling military forces from greater distances, but—if we have the choice—is this the direction we want to take?

Operation Desert Storm provides the military services with an opportunity to take a fresh look at their command and control orientation. In the wake of the Gulf War, we are at a watershed in deciding whether we ought to retain our present command and control orientation or develop a new, more modern command *or* control orientation. Will the capabilities provided by information technology be so seductive that we retain a

centralized control and rigid hierarchical organizational orientation, or should we embrace a new orientation of decentralized control and a more flexible organizational structure?

Unfortunately, there is no consensus in answering this question among the services. The Army's Force XXI concept and the Marine Corp's Sea Dragon concept see information technologies as a means for greater decentralization of command and control. The Air Force, on the other hand, sees information technology as providing a means not only for more centralized control but possibly for centralized execution as well.<sup>31</sup>

Perhaps the problem is in only seeing the impact of technology on control and not on command. Technology offers new means to gather information and make decisions; however, unless we take advantage of these opportunities, we will continue to have information-age capabilities constrained by industrial-age organizational thinking, orientation, and procedures.

## Notes

1 Frank M. Snyder, *Command and Control: The Literature and Commentaries* (Washington, D.C.: National Defense University, 1993), 15.

2 Col John A. Warden III, *The Air Campaign: Planning for Combat* (Washington D.C.: Pergamon-Brassey's, 1989), 44

3 John Keegan, *The Mask of Command* (New York: Penguin Books, 1987), 40.

4 *Ibid.*, 36–37.

5 Thomas P. Coakley, *Command and Control for War and Peace* (Washington, D.C.: National Defense University Press, 1992), 34.

6 Keegan, 55.

7 *Ibid.*, 90.

8 James P. Coyne, *Airpower in the Gulf* (Washington D.C.: The Air Force Association, 1992), as quoted in Alan D. Campen, ed., *The First Information War*, (Fairfax, Va.: ARMED FORCES COMMUNICATIONS ELECTRONICS ASSOCIATION International Press, October 1992), x.

9 Martin van Creveld, *Command in War* (Cambridge, Mass.: Howard University Press, 1985) 10–11.

10 Michael Howard and Peter Paret, eds., *Carl von Clausewitz: On War* (Princeton, NJ: Princeton University Press, 1989), 101.

11 John R. Boyd, "Patterns of Conflict" notes, in *A Discourse on Winning and Losing*, a selection of unpublished notes and visual aids compiled from 1976–1992, 46.

12 Van Creveld, *Command in War*, 75.

13 Martin van Creveld, *The Transformation of War* (New York: The Free Press, 1991), 109.

14 Van Creveld, *Command in War*, 104–105.

15 Boyd, 38–39; However, Van Creveld presents a more positive impression of Napoléon's command style in *Command in War*, 96–102. I believe there is no inconsistency, as Van Creveld describes Napoléon's early success while Boyd's focus is more on Napoléon's eventual failure.

16 Van Creveld, *Command in War*, 108.

17 Roger Beaumont, *The Nerves of War* (Fairfax, Va.: Armed Forces Communications Electronics Association International Press, 1986), 9.

18 Col S. L. A. Marshall, *Men Against Fire* (New York: William Morrow and Company, 1947), 93.

19 Van Creveld, *Command in War*, 108.

20 Daniel J. Hughes, ed., *Moltke on the Art of War: Selected Writings* (Novato, Calif.: Presidio Press, 1993), 77. Italics added to highlight the relationship between technology (i.e., the telegraph) and rapid decision making, which is discussed in greater detail later in the paper.

21 Beaumont, 28.

22 Maj Gen J. F. C. Fuller, *Generalship: Its Diseases and Their Cure* (Harrisburg, Pa.: Military Service Publishing Co., 1936), 61.

23 Snyder, 148.

24 Ibid.

25 Ibid., 61.

26 Van Creveld, *Command in War*, 238.

27 Campen, 1.

28 Beaumont, 22

29 Ibid.

30 Ibid.

31 Col Jeffery R. Barnett, *Future War: An Assessment of Aerospace Campaigns in 2010* (Maxwell AFB, Ala.: Air University Press, January 1996), 33. An academic advisor suggests that this might be “yet another case of obsessive concern over anything that might threaten our autonomy and independence as a service.” Personal note, 16 March 1996.

## Chapter 4

### An Organizational Orientation Model

Van Creveld points out that although the functions of command do not change over time, the means to carry out that command change quite often.<sup>1</sup> He divides the means of command into three categories: organizations, procedures, and the technical means which help determine the degree of control exercised by that commander.<sup>2</sup> For example, sensor and communications technologies have changed at a more rapid rate than have organizational structures and operating procedures for employing them. Today's military services have progressed from the telegraph to microburst transmitters, but they still operate under the same centralized control and hierarchical organizational orientation employed by Frederick the Great and Napoléon. The danger is that this industrial-age command and control orientation corrodes the benefits offered by the new information technology. The primary impact will be felt if a commander's information-gathering and decision-making processes do not keep up with the increased operations tempo of future warfare.

A key characteristic of future warfare is increased operations tempo, which stresses a commander's ability to observe and react to changes in the battlespace. JCS Pub 3-0 acknowledges that "the tempo of warfare has increased over time as technological advancements and innovative doctrines have been applied to military requirements."<sup>3</sup> Thus, the commander operating at a slower tempo than the opposing commander will be at a greater disadvantage because there is a greater degree of uncertainty. This is possible because the commander operating at a faster tempo than his opponent will always be one step ahead and actually setting the tempo. John Boyd addresses the commander's decision-making process as a continuous four-step

mental process—observation, orientation, decision, and action (OODA).<sup>4</sup> Using the Boyd model, successful commanders are those with the capability to operate within their adversaries’ OODA loop.

The ability to observe, orient, decide, and act faster than your opponent is necessary for future warfare. In *War in the Information Age*, Gen Gordon Sullivan, a former US Army chief of staff, observes that throughout history the tempo of operations caused by the impact of technology in warfare has accelerated (fig. 4-1).<sup>5</sup>

	<i>Revolutionary War</i>	<i>Civil War</i>	<i>World War II</i>	<i>Gulf War</i>	<i>War of Tomorrow</i>
<b>Observe</b>	Telescope	Telegraph	Radio/Wire	Near Real Time	Real Time
<b>Orient</b>	Weeks	Days	Hours	Minutes	Continuous
<b>Decide</b>	Months	Weeks	Days	Hours	Immediate
<b>Act</b>	A Season	A Month	A Week	A Day	Less Than An Hour

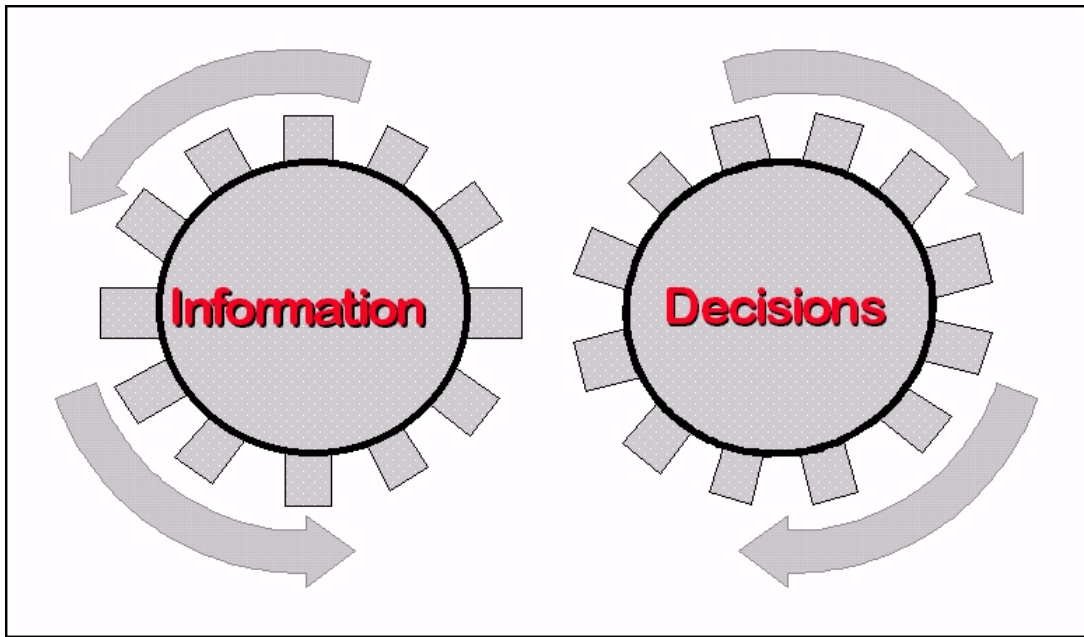
**Source:** Sullivan, Gordon R. and James M. Dubik, *War in the Information Age*.

**Figure 4-1. Tempo and Command**

Information technology has decreased the time available for commanders to gather information and make decisions. Notice that the time differential between orienting (finding out “What is actually happening?”) and deciding (“What can I or should I do about it?”) has compressed to the point that in information-age warfare, orienting and deciding can no longer be sequential actions but must be simultaneous, continuous actions. Thus, organizational orientation and procedures are critical components in determining the tempo of a commander’s OODA loop.

To better understand this process, we may consider the OODA loop in a different paradigm--as really two separate cycles, or processes, operating at the same time (*fig. 4-2*). The first cycle is the information gathering cycle, which addresses the commander’s need to find out “What is actually happening?” The second cycle is the decision-making cycle, which addresses the commander’s need to decide “What can I or should I do about it?” In this model, the information cycle loosely incorporates Boyd’s observation and orientation functions while the decision-making cycle incorporates the decision and action functions.<sup>6</sup>





**Figure 4-2. C<sup>2</sup> Dynamics**

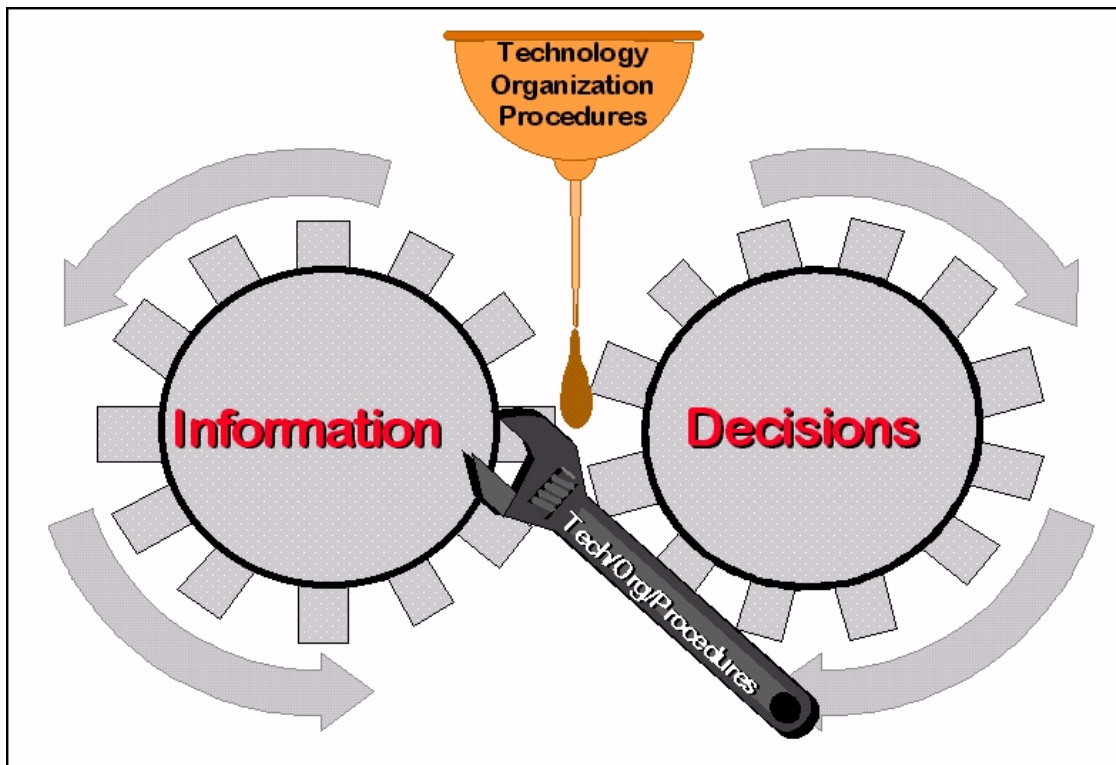
With the use of this model, we can examine the impact of tempo and technology on organizational orientation.

First of all, consider the commander with a very effective information-gathering capability who yet defers a decision, refuses to make a decision, or makes a wrong decision. While his or her ability to observe and orient is high, the commander may not have the temperament or capability to decide and act on that information. The model tells us that the information-gathering cycle is operating faster in this case than the decision-making cycle, creating an imbalance. While the commander's uncertainty level may be relatively low, it is of no advantage to the troops because the commander is incapable of using the control process to command appropriate action.

Now consider the commander with poor information-gathering capability who nevertheless decides and acts correctly at the right time based on *whatever* information was available. While the commander's information gathering was poor or incomplete, by temperament, training, doctrine, and faith such commanders overcome uncertainty and decide the best course of action. In this case the commander's decision-making cycle is operating relatively faster than his information-gathering cycle, again creating an imbalance.

The balance between the information-gathering and decision-making cycles is critical because it impacts a commander's operating tempo. As Boyd points out, from an external viewpoint it is critical for a commander to operate faster than an adversary or within an adversary's OODA loop. The means to do so,

however, require internal balance between a commander's information-gathering and decision-making cycles. Faster decisions can be possible because of faster information technology. Of course, faster does not imply better information or even better decisions. Even under ideal conditions, it is difficult to always have "perfect" information and to always make perfect decisions, a state where the information-gathering and decision-making cycles are working in harmony. While friction will always be a factor, it is technology, organization, and procedures that either act as a lubricant or throw a wrench into the balancing of the information-gathering and decision-making cycles (fig. 4-3).



**Figure 4-3. Technology/Organization/Procedures Impact**

It is the balance between information gathering and decision making that helps determine the amount of uncertainty.

As mentioned earlier, information gathering is critical to addressing the problem of uncertainty. As John Schmitt explains, there are two possible responses. One is to pursue certainty as the basis for command and control. The second is to accept uncertainty as a fact of war and function with it.<sup>7</sup> The first response is to eliminate uncertainty by creating a highly efficient command and control structure based on the quest for close control:

In such a system, the commander controls with a “tight rein.” Command and control is centralized, formal, and inflexible[whereas] detailed control requires strict obedience and minimizes subordinate decision making and initiative.<sup>8</sup>

Thus, there may be greater certainty at the top but decreased certainty at the bottom. As Schmitt points out, if we accept that war is inherently uncertain, then this kind of orientation attempts to overcome a fundamental nature of war, one that we will never successfully overcome.<sup>9</sup>

This makes the second approach, that of operating with a certain amount of uncertainty, a more pragmatic command and control orientation. Schmitt states that “rather than increasing the degree of certainty we *achieve*, we reduce the degree of certainty that we *need*.”<sup>10</sup> The result is a command and control orientation that is decentralized:

In such a system, the commander controls with a loose rein, allowing subordinates significant freedom of action and requiring them to act with initiative. . . . Command and control is decentralized, informal, and flexible [which] seeks to increase tempo and improve the ability to deal with fluid and disorderly situations.<sup>11</sup>

Decentralized control allows for some uncertainty at the top to allow for greater certainty and decision making at the bottom. The greater the degree of control, the less the number of alternatives available to solving a problem.<sup>12</sup> For example, numerous laboratory tests indicate that teams placed under increased stress operate more efficiently and correctly when there is less shared uncertainty coupled with decentralized decision making.<sup>13</sup> Thus, the ability to gather vital information and make appropriate decisions rapidly is very dependent on the command and control orientation.

Modern technological advances, particularly in the area of computers and communications systems, increase the likelihood that the information-gathering and decision-making cycles will be unbalanced. In fact, technology is the contributing factor for having two separate cycles. In preindustrial warfare, Alexander the Great’s personal command style was such that his information- gathering process and decision-making cycles were in harmony. He saw what was happening on the battlefield, made decisions, and took actions based on his personal observations. This is the classic OODA loop, a very sequential process. In preindustrial-age warfare, technology, organization, and procedures were relatively simple.

One of the major characteristics of industrial-age warfare is movement made possible by the internal combustion engine. Vehicles, and the things they transport, move at high speeds. Armies are mechanized and mounted. There are relevant objects in space and beneath the sea. All of these fast-moving objects must be

observed to orient. The consequence is an increase in uncertainty. Faster information-gathering capabilities increase the potential for dealing with panoramic multimedia changes and suspicious, contradictory, or incomplete information, making the decision-making process more difficult. This increase in information-gathering capabilities is a result of technological advances in the information, intelligence, computer, and communications fields. The volume of data processing is growing exponentially, with capacities doubling approximately every 18 months. The maximum communications throughput of two megabits per second in Operation Desert Storm will seem slow when compared to the impending capacity of 30 megabits per second.<sup>14</sup> The result is a faster, technologically driven information-gathering cycle, but a decision-making cycle that has not gotten appreciably faster since the days of Alexander the Great. Making decisions is still very much a human chore.

Unfortunately, decision-making technology, such as computer-assisted logic tools and artificial intelligence, has not progressed as rapidly as information-gathering technology. Technology is making more and more information available, but the commander's ability to process and act on that information is still limited to how much the commander's brain can comprehend. It is organization and procedures that try to reestablish the balance between the process of information gathering and the process of decision making to direct action. Technology and operating procedures can either add friction or mitigate it. Both technology and operating procedures are strongly affected by organizational structure and organizational orientation.

The two most common types of command and control organizational orientations, and hence structures, are hierarchical types and networked types. The traditional military command and control orientation is hierarchical. This came about because traditionally hierarchical organizations required less communications' which substantially simplified the planning and control process.<sup>15</sup> George Orr describes a hierarchical organization as one that

attempts to turn the entire military force into an extension of the commander. Subordinate levels respond in precise and standardized ways to his orders and provide him with the data necessary to control the entire military apparatus. The emphasis is upon connectivity hierarchy, upon global information gathering or upon passing locally obtained information to higher levels, and upon centralized management of the global battle.<sup>16</sup>

The key is that both information gathering and decision making are under the personal control of the commander. Power at each level of command within the hierarchical organization is a function of both how much information and the kind of information controlled.

The first problem is that the very nature of controlling information defeats the optimum use of that information. Information gathering and decision making must be made at each level of command before that information is moved on. At each level of command. The information is filtered, added, deleted, and modified. This is a time-consuming process, often resulting in information not reaching the right people or getting there too late to be of any use. This creates a cascading effect, as controlled information becomes slow information. This last point is often cited as a failure of “intelligence” not getting to the right people on time. Perhaps the problem is not with the intelligence process, but rather the hierarchical organization it is supporting. Information must move with a degree of freedom at all levels of command to better balance decision making at all levels of command.

A second problem with hierarchical organizations is a tendency to control decision making at the highest levels of the organization. Again, technological advances drive higher levels of centralized control, threatening to stifle ingenuity and initiative at the lower levels. Combating this temptation requires trust in subordinates. During the Civil War, Gen Ulysses Grant, though he had the technical capacity to centrally manage the war, was successful because he “trusted subordinates thoroughly, giving only general directions, not hampering them with petty instructions.”<sup>17</sup> Gen Dwight D. Eisenhower seemed to support this approach on the art of high command: “He can and should delegate tactical responsibility and avoid interference in the authority of his selected subordinates.”<sup>18</sup> Gen Norman Schwarzkopf applied this lesson into joint war fighting by attesting, “I built trust among my components because I trusted them. . . .If you want true jointness, a commander in chief (CINC) should not dabble in the details of component business.”<sup>19</sup> This freedom from interference is extremely important, as Sir William Slim explains:

Commanders at all levels had to act more on their own; they were given greater latitude to work out their own plans to achieve what they knew was the Army Commander’s intention. In time they developed to a marked degree a flexibility of mind and a firmness of decision that enabled them to act swiftly to take advantage of sudden information or changing circumstances without reference to their superiors.<sup>20</sup>

Thus, faster decision making in response to the faster tempo of war requires an orientation of decentralized control.

Unlike hierarchical organizations, networked organizations offer a decentralized control orientation that makes better use of information technology. RAND’s John Arquilla and David Ronfeldt point out that the advances in computers and information technologies influence related innovations in organization and

management theory.<sup>21</sup> This is reinforced by John Naisbitt's book *Megatrends* and the Air Force Scientific Advisory Board, which predicts that organizational changes will result as we transition from an industrial-based society to an information-based one.<sup>22</sup> This trend will drive hierarchical organizations to become networked organizations, and centralized control should yield to decentralized control. George Orr defines a networked organization as one that

views the commander as controlling only in the sense of directing a cooperative problem-solving effort. The emphasis in this style is on autonomous operation at all levels, upon the development of distributed systems and architectures, upon networking to share the elements needed to detect and resolve possible conflicts, and upon distributed decision making processes.<sup>23</sup>

In a networked organization, the information-gathering process will be more equally distributed and more information will be available more rapidly to all levels of command. Commanders will share rather than control information, resulting in faster decision making at all levels of command.

A networked sharing of information is much different than that of the hierarchical control of information. A faster decision-making cycle is possible with shared information. This also provides all levels of command with approximately the same level of certainty. It also eliminates irritants. For example, Admiral Metcalf, Task Force 120 commander during Operation Urgent Fury, remembered his experiences from Vietnam with the "long-distance screwdriver."<sup>24</sup> To prevent recurrence, he worked hard at increasing the confidence and certainty of his superiors by providing them with masses of information during the operation to liberate Grenada.<sup>25</sup>

More important than the elimination of irritants, however, is another advantage of networked information sharing: troops engaged will have and generate more information than the "headquarters." If warfare is "chaotic," the chaos arises from adding information or energy to a system. Since troops in contact will be the first to observe that information, they must be empowered to use it for their decision making. What appears to be chaotic and uncertain to the headquarters may be much less chaotic and much more certain to troops empowered to respond to "local conditions." Headquarters, then, can use information technology as Boyd suggests: to monitor.

While the principle of sharing information at all levels of command is important, it is modern information technology that makes it more usable. By using better communications and computer technology, Central Command was able to share information during Operation Earnest Will in the Persian Gulf with great

success. Admiral Jerry Tuttle, then director of the Command, Control, and Communications Directorate of the Joint Staff (J-6), provided communications equipment for sharing information with national-and theater-level commanders:<sup>26</sup>

With the on-scene commander, Rear Admiral Less, the CINC (General Crist in Tampa, Florida), and the Secretary [of Defense] and the Chairman [of the JCS] all having the same picture and same databases, the requirement to communicate diminished markedly. By having red and blue forces depicted in one composite picture, the relative urgency for decision making could be readily determined and priorities set more intelligently<sup>27</sup>

While shared information decreases uncertainty, it has the added benefit of fostering decision making at lower levels of command. General Crist discovered that because the national command authorities were getting the same shared information, they did not feel compelled to monitor or control the operation by skip echelon.<sup>28</sup> As Paul Strassmann writes, “The more people share information, the more its importance will increase.”<sup>29</sup> Shared information provides the means to faster and decentralized decision making. To achieve faster decision making, it is critical that all levels of command are operating from a shared vision or commander’s intent. A commander’s intent is

a concise expression of the purpose of the operation and must be understood two echelons below the issuing commander. It must clearly state the purpose of the mission. It is the single unifying focus for all subordinate elements. . . Its purpose is to focus subordinates on the desired end state.<sup>30</sup>

Through a unifying commander’s intent, we can generate initiative. Boyd supports this assertion when discussing the ability to act faster than an opponent:

This is best accomplished by the exercise of initiative at the lower levels within a chain-of-command. However, this decentralized control of how things are done must be guided by a centralized command of what and why things are done.<sup>31</sup>

US Marine Corps FMFM 1-1 echoes this by stating, “We generate tempo by creating a command system based on decentralized decision making within the framework of a unifying intent.”<sup>32</sup> Therefore, the commander’s role is to establish the boundaries within which subordinate commanders can make decisions and increase operating tempo.

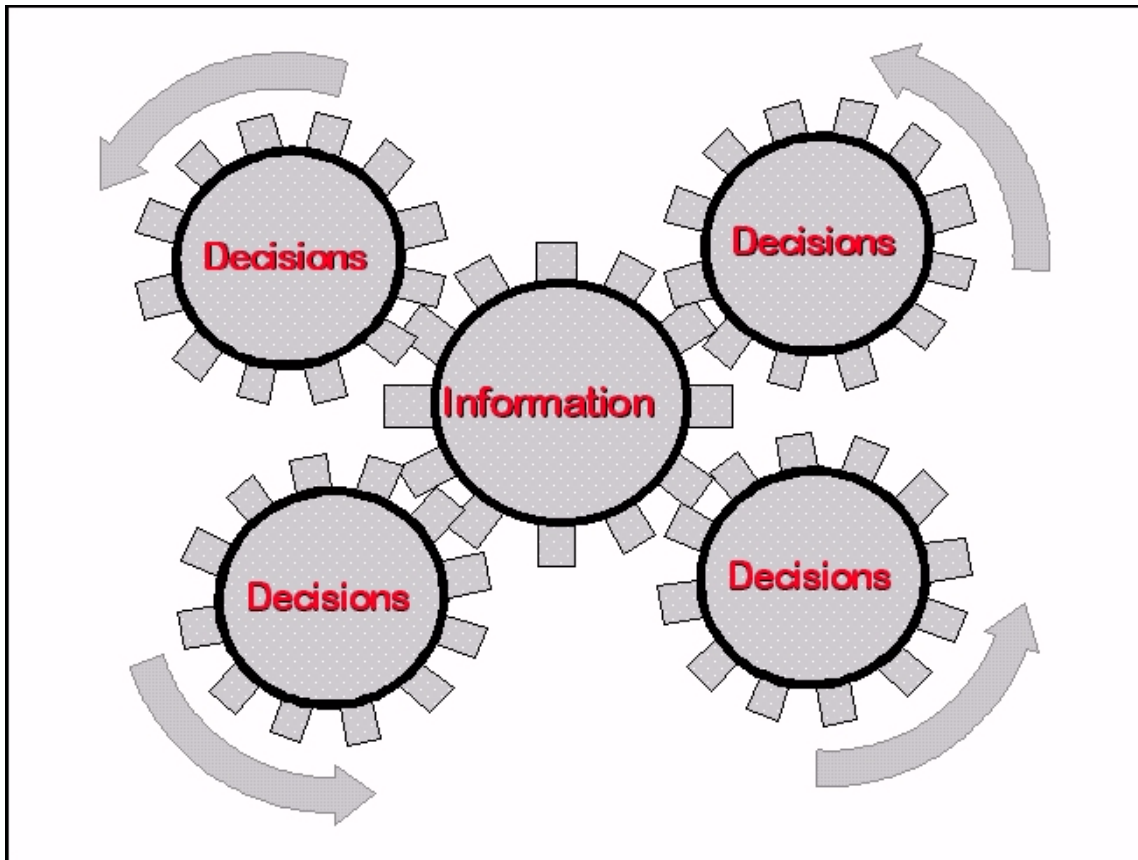
However, while a networked organization may be ideal for sharing information gathering, it may not be the best model for military commanders when dealing with tough decisions in combat. Unlike their business counterparts, military commanders must really make life-and-death decisions and put subordinates at risk. In a networked organization, who among the collaborators will make those decisions? War requires

commanders, not collaborators. Thus, decision making may be more a hierarchical function than information gathering. For example, the success of a deception plan usually requires fooling your own troops. During Operation Desert Storm, the US marines afloat off the coast of Kuwait may have conducted their daily preparations and routines differently, even subconsciously, had they been aware that their amphibious landing preparations were only a ruse. Their subtle changes in behavior or an inadvertent communications transmission might have been detected by the Iraqis, thus compromising the deception plan. Thus, some type of hierarchical organization is needed to support the decision-making process, though it can be made more effective.

The answer is a flattened hierarchical organization which greatly facilitates a commander's decision-making process. Eliminating layers of command between the commander and operational forces facilitates the execution of those decisions. The goal is combining a clearly defined commander's intent with decentralized control at all levels of command, allowing for greater flexibility, ingenuity, and initiative. The German concept of *Auftragstaktik* during World War II demonstrates how this works. German commanders at each echelon, when out of contact with higher echelons, were free to operate in meeting objectives at two levels higher than their command without specific permission. Each level of command understood the commander's intent and what other commanders were expected to do.<sup>33</sup> This Germans' decentralized decision-making cycle was able to operate at a faster tempo than that of the opponents. For example, German counterattacks were often conducted within 30 minutes after losing a position, while American, British, Russian and French counterattacks usually took hours.<sup>34</sup> The German decision-making process, facilitated by decentralized control, allowed them to operate within the OODA loop of their adversary.

Thus, the ideal command and control organization combines the shared information-gathering advantages of the networked organization with the decision-making advantages of a decentralized, flattened hierarchical organization (fig. 4-4).<sup>35</sup>





**Figure 4-4. Shared Information/Decision Process**

John Warden's experiences from the Gulf War support this orientation.

The coalition managed its own information requirements acceptably, even though it was organized in the same way Frederick the Great had organized himself. Clear in the future is the requirement to redesign our organizations so they are built to exploit modern information-handling equipment. This also means flattening organizations, eliminating most middle management, pushing decision making to very low levels, and forming worldwide neural networks to capitalize on the ability of units in and out of the direct conflict area.<sup>36</sup>

Thus, to maximize the advantages from information technology, one must redesign the military organizational orientation.

Modern technology can help redesign a military organization based on a theory of "centralized command decentralized control and execution," which mirrors the "massively parallel" designs of modern computers.<sup>37</sup> To support information gathering;

each BAU [Basic Action Unit] has direct access to the situation model. This is achieved by linking all the units together in a single data net. . . .The BAU commander can then access the battlefield model and pull out the information they need to accomplish their objectives.<sup>38</sup>

To support decision making;

the command unit does not issue explicit orders but identifies mission objectives and a focus of main effort. . . .The BAUs are given wide latitude in conducting their mission. Coherence is achieved because all the units share a common doctrine, a common goal, and a common view of the situation. . . .Instead of waiting for exact orders to funnel through intermediate units, each BAU will access its mission order against the common modal and act accordingly.<sup>39</sup>

This concept of a shared information-gathering cycle and a decentralized decision-making cycle is being discussed among the military services, but there is no agreement on what organizational orientation is best suited to take advantage of information technology. The only agreement is that organizational change eventually will happen.

## Notes

1 Martin van Creveld, *Command in War*, 9.

2 Ibid., 10.

3 JCS Pub 3, *Doctrine for Joint Operations* (Washington, D.C.: Joint Chiefs of Staff, 1 February 1995), III-15.

4 John R. Boyd, "Organic Design for Command and Control" A Discourse on Winning and Losing, selection of unpublished notes and visual aids, 5-12.

5 Gen Gordon R. Sullivan and Colonel James M. Dubik, *War in the Information Age* (Carlisle Barracks, Pa.: US Army War College, 4 June 1994), 5.

6 Although Col Boyd cautioned against separating these functions in a telephone interview on 20 March 1996, it is just this kind of "analysis" (or destructive deduction) he argues for in his 3 September 1976 "Creation and Destruction" notes, 5-17.

7 John F. Schmitt, "A Concept for Marine Corps Command and Control," *Science of Command and Control: Part III*, by Alexander H. Levis and Ilze S. Levis, ed. (Fairfax, Va: Armed Forces Communications Electronics Association International Press, 1994), p. 17.

8 Ibid.

9 Ibid.

10 Ibid.

11 Ibid.

12 John P. Crecine and Michael D. Salomone, "Organization Theory and C<sup>3</sup>," in *Science of Command and Control: Part II*, Stuart E. Johnson and Alexander H. Levis, eds. (Fairfax, Va.: ARMED FORCES COMMUNICATIONS ELECTRONICS ASSOCIATION International Press, 1989), 50.

13 Proceedings of the 1992 Symposium on Command and Control Research, held at Naval Post Graduate School, Monterey, Calif., 12-14 June 1992, and compiled by Science Applications International Corp., McClean, Va. Some of the better studies include: "A C<sup>3</sup> Workstation Utilizing Value-Based Message Scheduling," by J. E. Bake, L. P. Clare, J. R. Agree and W. Heyman; "Horizontal and Vertical Structures in Small Teams: Team Performance and Communication Patterns," by Clint A. Bowers, Paul B. Kline, and Ben B. Morgan, Jr.; "The Application of a Model of Adaptive Decision Making to the Collection and Analysis of Domain Expertise," by Peter D. Morgan; and "Examining Cognitive Processing in Command Crises: New HEAT Experiments on Shared Battle Graphics and Time Tagging," by Dr Paul J. Hiniker and Dr Elliot E. Entin.

- 14 US Space Command briefing given to the Air War College during academic year 1995–1996. Used with permission.
- 15 Crecine and Salomone, 50.
- 16 Maj George E. Orr, *Combat Operations C<sup>3</sup>I: Fundamentals and Interactions* (Maxwell AFB, Ala.: Air University Press, July 1983), 87–88.
- 17 Maj John M. Vermillion, “The Pillars of Generalship,” *Parameters*, Summer 1987, 11.
- 18 Edgar F. Puryear, Jr., *Nineteen Stars: A Study in Military Character and Leadership* (Novato, Calif.: Presidio Press), 229.
- 19 Joint Pub 1, II-6.
- 20 Sir William Slim, *Defeat Into Victory* (London: Cassell and Company, 1956), 292.
- 21 John Arquilla and David Ronfeldt, “Cyberwar is Coming”, RAND Study P-7791, Air University Library Document, M-U 30352-16, no. 7,791), 2.
- 22 John Naisbitt, *Megatrends* (New York: Warner Books, 1982), 1–2.
- 23 Orr, 88.
- 24 Raymond C. Bjorklund, *The Dollars and Sense of Command and Control* (Washington, D.C.: National Defense University Press, 1995), 79.
- 25 Ibid.
- 26 Ibid., 83.
- 27 Vice Adm Jerry O. Tuttle, “C<sup>3</sup>, An Operational Perspective,” in *Science of Command and Control: Part II*,. Va.: 4.
- 28 Bjorklund, 83.
- 29 Ibid., 85.
- 30 FM 100-5, *Operations* (Washington, D.C.: Department of the Army, 14 June 1993), 6–6.
- 31 Maj David S. Fadok, “John Boyd and John Warden: Airpower’s Quest for Strategic Paralysis” (Maxwell AFB, Ala.: Air University Press, February 1995), 15.
- 32 US Marine Corps FMFM 1-1, *Campaigning* ( Washington, D.C.: Department of the Navy, 25 January 1990), 73.
- 33 James G. Hunt and John D. Blair, eds. *Leadership on the Future Battlefield* (London: Pergamon-Brassey’s, 1985), 183.
- 34 Ibid.
- 35 I am deeply indebted to Maj Patrick Pope, a fellow Air Force 2025 colleague, whose wise counsel, shared interest, energy, and computer wizardry helped channel many of my random thoughts into a coherent pattern.
- 36 Barry R. Schneider, “Principles of War for the Battlefield of the Future,” *Battlefield of the Future*, ed. Barry R. Schneider and Lawrence E. Grinter (Maxwell AFB, Ala.: Air University Press, September 1995), 36–37.
- 37 1stLt Gary A. Vincent, “A New Approach to Command and Control: The Cybernetic Design,” *Airpower Journal*, (Summer 1993), 29 and 31.
- 38 Ibid., 30–31.
- 39 Ibid.

## Chapter 5

### Differing Service Orientations

US military service organizational orientations for information-age warfare are striking in their contrast. There is general agreement that the operations tempo of Operation Desert Storm may be slow compared to that of future wars. Here is how the various military service doctrines define tempo:

US Army: “Tempo is the rate of speed of military action; controlling or altering that rate is essential for maintaining the initiative. A quick tempo demands an ability to make tactical decisions quickly, to execute operations that deny the enemy a pause, and to exploit opportunities according to commander’s intent.”<sup>1</sup>

US Marine Corps: “Tempo is a rate or rhythm of activity. Tempo is a significant weapon because it is through a faster tempo that we seize the initiative and dictate the terms of war.”<sup>2</sup>

US Navy: “Tempo is the pace of action—the rate at which we drive events. One way of doing this is to exploit the dynamics of warfighting by maintaining a high tempo.”<sup>3</sup>

US Air Force: There is no mention of tempo in current or proposed Air Force doctrine. However, “speed” is mentioned as a characteristic of airpower.<sup>4</sup>

Why does the Air Force emphasize speed over tempo? Tempo is defined as speed over time—the consistent ability to operate fast.<sup>5</sup> One might well argue that tempo, not speed, is a more accurate description of the desired characteristics of airpower. Speed is more a characteristic of airpower technology, that is, the speed of the aircraft, or how long it takes to hit the target, while tempo is more a characteristic of command and control orientation. In a 1995 speech, the Air Force chief of staff stated that “Not too far in the next century, we may be able to engage 1,500 targets within the first hour, if not the first minutes, of a conflict.”<sup>6</sup> This describes speed, not tempo. The real question is what happens after the first strike? Do we have a command and control orientation that maintains and even increases the tempo of operations? If our doctrine remains

one of “centralized control, decentralized execution,” then it is unlikely “tempo” will increase throughout the course of the war.

With the exception of the Air Force, every US military service recognizes that increased operations tempo requires decentralizing control and decision making to the lowest level. These service observations are fairly clear:

Army: “Initiative requires the decentralization of decision making to the lowest practical level.”<sup>7</sup>

Marine Corps: “In order to generate the tempo of operations we desire and to best cope with the uncertainty, disorder, and fluidity of combat, command must be decentralized.”<sup>8</sup>

Navy: “A rapid tempo requires that commanders be provided . . . enough decentralization to allow subordinate commanders to exploit opportunities.”<sup>9</sup>

Air Force: “To exploit speed, range, flexibility, precision, and lethality that makes air and space so versatile, their organization must make it possible for missions to be centrally controlled. The need to respond to and exploit unforeseeable events requires that these same forces are capable of decentralized execution.”<sup>10</sup>

In the aftermath of Operation Desert Storm, the Army Force XXI concept and Marine Corps Sea Dragon concept are the respective services’ thinking about future warfare which emphasizes decentralized control and decision making. The Air Force has no such new paradigm.

## Notes

1 FM 100-5, *Operations* (Washington, D.C.: Department of the Army, 14 June 1993), 7-2 and 7-3.

2 FMFM 1-1, *Campaigning* (Washington, D.C.: Department of the Navy, 25 June 1990), 72–73.

3 Naval Doctrine Publication 1, *Naval Warfare* (Washington, D.C.: Department of the Navy, 28 March 1994), 40–41.

4 Speed is referenced in both the draft “Air Force Doctrine Document 1”, 15 August 1995, 24, and AFM 1-1, *Basic Aerospace Doctrine of the United States Air Force*, vol. 1 March 1992, 18 (Washington D.C.: Department of the Air Force) March 1992,. Of interest, the 1986 version of AFM 1-1 reflects the Air Force thinking about timing and tempo as a possible new principle of war, but any discussion of timing and tempos was dropped in later versions.

5 FMFM 1-1, 32.

6 Gen Ronald R. Fogelman, “Getting the Air Force into the 21st Century,” speech to the Air Force Association’s Air Warfare Symposium, Orlando, Fla., 24 February 1995.

7 FM 100-5, 2–6.

8 FMFM 1-1, pp. 61–62.

9 Naval Doctrine Publication 1, 40.

10 Air Force Doctrine Document 1 draft, 24.

## Chapter 6

### The Air Force Orientation

The Air Force is taking a much different direction because it remains rooted to an orientation of centralized control-decentralized execution, which Eliot Cohen describes as “a catchphrase of Air Force doctrine, much as ‘don’t divide the fleet’ preoccupied American naval strategists in earlier times.”<sup>1</sup> Although Air Force doctrine has changed 12 times, based on 50 years of experience (another change is in draft), doctrine is now the basis for increased centralized control through the joint forces air component commander (JFACC) concept and the air tasking order (ATO) process.<sup>2</sup>

The seductive effect of information technology is seen in those proponents advocating stronger centralized control. For example, some have advocated that future aerospace operations not only require greater centralized control, but increasingly *centralized execution*. Col Jeff Barnett, in his book *Future War*, argues that “only a centralized C<sup>2</sup> system has the potential to deconflict these factors in the chaos of war” and that “decentralized execution, effective in past wars, won’t answer this challenge.”<sup>3</sup> He goes on to suggest that the JFACC has the technology and should conduct future warfare from the continental United States. Unfortunately, this thinking increases the danger of military micromanagement at a time when just the opposite is desired. As Eliot Cohen argues:

A general in Washington, an admiral in a command ship or a theater commander in rear headquarters may have access to almost the same information as a forward commander, and in some cases more. Those distant commanders will often succumb to the temptation to manipulate individual units in combat accordingly.<sup>4</sup>

In many ways, the ATO reflects JFACC micromanagement of airpower through centralized control.

Highly centralized, the ATO is the tool of inflexibility. The Gulf War Air Power Survey Summary (GWAPSS) Report notes that “the ATO process used by the air planners and commanders in Riyadh merely

modified an approach long used within NATO; it also bore a striking family resemblance to the way American planners had constructed and executed air campaigns as far back as World War II.”<sup>5</sup> A common understanding was that “An airplane didn’t fly unless it was in the ATO.”<sup>6</sup> The reaction of one squadron commander to the ATO was typical: “By day three, the ATO was basically a historical document that described what we were supposed to do after we have already done it. Virtually all our tasking was received by phone and changes were the rule.”<sup>7</sup> Twenty percent of all air missions were changed during the few hours between the printing of the ATO and the time the aircrews launched. Still more changes were made before the ATO was officially released or after the aircraft had left their bases.<sup>8</sup> Much as our model predicts and as Cohen points out, “Sometimes these decisions made sense; other times they did not. In all cases they created great uncertainty among the pilots flying the missions.”<sup>9</sup>

The reaction of other services to the slow ATO process was equally harsh. One US marine experience described the ATO process as “an attempt to run a minute-by-minute air war at a 72-hour pace.”<sup>10</sup> Marine Corps Gen Royal N. Moore commented:

It [ATO] does not respond well to a quick-action battlefield. If you’re trying to build a war for the next 72 to 96 hours, you can probably build a pretty good war. But if you’re trying to fight a fluid battlefield like we were on, then you need a system that can react.<sup>11</sup>

There was even criticism from a US Navy admiral claiming that the Iraqis had figured out the 72-hour nature of the ATO and were moving aircraft around within that window.<sup>12</sup> That Saddam Hussein was able to operate within the OODA loop of the Air Force gives him more credit than he deserves and is probably more reflective of service parochialism about the JFACC and ATO process than an accurate characteristic of one of the world’s worst generals. However, the admiral is correct about the ATO process being a dinosaur of industrial-age warfare. The timeliness of the ATO calls into question its value in a fast-tempo war.

Perhaps the concept of centralized command decentralized control and execution is an idea whose time has come. Fast-tempo warfare, with the need for balanced information sharing and decision making, requires a new command and control orientation. Cohen believes that “a new concept of high command, one that acknowledges that technology inevitably diffuses authority, will have to take root.”<sup>13</sup> Certainly, if technology provides the means for transmitting a 300-page ATO, that same technology could be applied in making airpower more responsive. The GWAPSS Report points out that “coalition commanders relied on an air-

tasking system whose cycle times . . . had not changed appreciably from the Vietnam era.”<sup>14</sup> It is little wonder then that we had much greater success against stationary targets than against the mobile Scud launchers; and this was against a relatively benign enemy with a snail-like operations tempo. As US Navy Capt Lyle G. Bien observes, “The 48-hour ATO cycle did not permit rapid response to mobile targets.”<sup>15</sup> We may not be so fortunate in the future if the number of mobile targets increases, or if enemies become more agile.

What is required is an organizational orientation that will take advantage of this information technology for faster information-gathering and decision-making cycles. As General Gordon Sullivan points out, “The present, regular ‘conveyor-belt’ pace of the machine age is over. Only fast-paced, adaptive organizations will succeed.”<sup>16</sup> There are those who argue that airpower is different than land and sea forces, because it requires greater, not lesser, centralized control. Any discussion of decentralized control immediately brings forth historical failures of airpower, such as “penny packets” during the North African campaign of World War II and “route packaging” of Vietnam.<sup>17</sup> But, information technology has come a long way in 25 years, demanding that a fresh organizational orientation be made.

The advantages of decentralized control in the fast-paced tempo of future wars make it essential for the Air Force to give it greater attention by relooking at the ATO process. Former Air Force Chief of Staff Gen Larry Welch said, “I believe we overcontrolled in Desert Storm. We did focus on the CINC’s intent . . . but it took us 5000 pages and 72 hours to produce an ATO.”<sup>18</sup> Gen Merrill A. McPeak, the Air Force Chief of Staff during Operation Desert Storm, expressed interest in exploring mission-type orders to try and shorten the ATO cycle:

It is a disgrace that modern air forces are still shackled to a planning and execution process that lasts three days. We have hitched our jets to a hot air balloon. Even when this lackluster C<sup>2</sup> system works properly, we are bound to forfeit much of the combat edge we know accrues to airpower because of its flexibility and speed of response.<sup>19</sup>

As one Air Force officer notes, “Mission-type orders are the laxative for constipated communications.”<sup>20</sup>

However, institutional orientation continues to be that the ATO must be centralized at the top. Thus, the only improvements sought will be in shortening the ATO cycle rather than looking at alternatives. In any case, there appears to be little interest in the Air Force joining the other services in advocating a new command



and control orientation. Without a fresh perspective, the Air Force may not be able to operate at the operations tempo demanded in future information-age warfare.

## Notes

1 Eliot A. Cohen, "The Mystique of U.S. Air Power," *Foreign Affairs*, Jan/Feb 1994, 389.

2 It is interesting that during Operation Desert Storm, the Air Force correctly identified Saddam Hussein's hierarchical organizational orientation with its highly centralized control as a vulnerability. Destroying or disrupting key control facilities and communications paths was necessary to induce strategic paralysis at all levels of Iraqi command. Yet, ironically, American-led airpower had a similar organizational orientation and, likewise, similar vulnerabilities.

3 Jeffery R. Barnett, *Future War: An Assessment of Aerospace Campaign in 2010* (Maxwell AFB, Ala.: Air University Press, 1996), 33.

4 Cohen, 388.

5 Thomas A. Keaney and Eliot A. Cohen, *Gulf War Air Power Survey Summary Report* (Washington, D.C.: Department of the Air Force, 1993), 247.

6 John P. Hyde, Johann W. Pfeiffer and Toby C. Logan, "CAFMS Goes to War," in *The First Information War*, Alan D. Campen, ed. (Fairfax, Va.: Armed Forces Communications Electronics Association International Press, October 1992), 44.

7 Maj J. Scott Norwood, "Thunderbolts and Eggshells" (Maxwell AFB, Ala.: Air University Press, September 1994), 24.

8 Cohen, 386.

9 Ibid.

10 Keaney and Cohen, 150.

11 Col Stephen J. McNamara, *Air Power's Gordian Knot: Centralized Control versus Organic Control* (Maxwell AFB, Ala.: Air University Press, 1994), 131.

12 Michael R. Gordon and Gen Bernard E. Trainor, *The Generals' War: The Inside Story of the Conflict in the Gulf* (Boston: Little, Brown and Company, 1995), 320. Vice Adm Stanley Arthur, senior Navy officer in the Persian Gulf, said that his intelligence officers were telling him that the Iraqis were moving what combat planes remained in Iraq every day or so, having discovered that it took three days to get all but the most critical targets on the allies' target list.

13 Cohen, 118.

14 Keaney and Cohen, 237.

15 McNamara, 131.

16 Gordon and Dubik, 9.

17 One of my fondest memories of the Air War College experience will be spirited arguments in the seminar room. None were more heated than over the Air Force doctrinal (or to some, "dogmatic") issue of "centralized control." I am deeply indebted to Lt Col Pivo Pivarsky, Lt Col Joe Sokol, and Lt Col Gary Coleman -- scholars and warriors all. Their intelligent, and usually emotional, debate helped keep me focused.

18 Maj Michael E. Fischer, "Mission-Type Orders in Joint Air Operations" (Maxwell AFB, Ala.: Air University Press, May 1995), 55.

19 Maj James P. Marshall, "Near-Real-Time Intelligence on the Tactical Battlefield" (Maxwell AFB, Ala.: Air University Press, January 1994), 66

20 Lt Col J. Taylor Sink, "Rethinking the Air Operations Center" (Maxwell AFB, Ala.: Air University Press, September 1994), 42.

## Chapter 7

### Recommendations

Technology is a tool, and humans decide how they will organize and how they will use the tools available. A screwdriver can be used as an icepick, and a person can pound nails with a laptop computer. Information technology—computer machines and communications devices—can enable us to fight more effectively. If fighting more effectively is the goal, we should decide how to organize to use these new tools to our best advantage. Thus these recommendations follow:

1. The US military must establish useful definitions to clarify command and control. We can eliminate considerable confusion by abolishing the use of command and control and reinforcing the importance of command. In its present context, command embraces planning, organizing, directing, coordinating, and controlling. Command has also proven to be the timeless notion in spite of organizational changes and technological advances. We must resist efforts to hang additional attributes on the function of command because that dilutes the most critical component of war: Command.

2. Information, by its very nature, is most useful when not hierarchically controlled. A characteristic of military hierarchies is control of information. We must take advantage of networked organizational orientation in providing access to shared information at all levels of command. Shared information helps reduce uncertainty and improve a commander's decision-making cycle. Given the danger of information overload, new technological innovations such as computer smart agents and data mining will allow commanders to tailor their information-gathering capabilities to meet their specific needs. Shared information gathering allows for increased operations tempo.

3. Decision making is most effective in a flattened hierarchical organization. Eliminating layers of command provides the means to operate at a higher tempo. Decentralized control also encourages innovation and initiative at the lowest levels of command and promotes morale.

4. The Air Force must reexamine the doctrine of centralized control, decentralized execution against an information-age adversary. The JFACC and ATO concepts are a product of hierarchical organizations and centralized control, perhaps the last vestiges of excessive concern over “independence.” While effective in industrial-age warfare, the limitations centralized control places on timeliness, flexibility, and tempo create potentially serious problems should we face an adversary operating at a faster operations tempo. The same technology that promotes greater centralized control can also apply to decentralized control. As Boyd points out, perhaps the JFACC’s primary role is that of “monitoring” and not “controlling.” We should expect future enemies to be smarter, not more stupid, than Saddam Hussein.<sup>1</sup> We should expect that joint and combined operations will require the Air Force to change, if the other services also change.

## Notes

<sup>1</sup> The only officers more stupid than Saddam Hussein were his sons-in-law. They were killed “by angry relatives” shortly after returning from self-imposed exile for denouncing their father-in-law.

## Chapter 8

### Conclusion

The command or control dilemma is real. The confusion starts with trying to establish a common frame of reference on exactly what command and control means. In future wars, characterized by increased operations tempo, the correct command and control orientation may be that of command *or* control. Centralized control exercised through hierarchical organizations reflects old and dangerous thinking against future enemies operating at a faster decision-making cycle. Greater access to shared information and decentralized decision making are key to operating at the tempo required in information age warfare. The US military has the information technology needed to operate at faster tempos, provided we have the correct organizational orientation and procedures to take advantage of it. Brig Gen Robert Eaglet points out that the command and control capability adopted by a nation should reflect and support those national characteristics that are its greatest strength. He identifies ingenuity, initiative, and *esprit de corps* as qualities Americans like to claim as national strengths, and the command style most appropriate for America should be designed to capitalize upon these characteristics.<sup>1</sup> As Carl Builder reminds us, “Each age of warfare required different treasured capabilities. In agrarian-age warfare, strength and cunning were valued. In industrial-age warfare, organization and discipline were valued. In information-age warfare, the treasured capabilities are knowledge and creativity.”<sup>2</sup> We must have the organizational orientation to take advantage of these capabilities. To do this, our most treasured military capability is, and will always be, enlightened command.

## Notes

1 George E. Orr, *Combat Operations C<sup>3</sup>I: Fundamentals and Interactions* (Maxwell AFB, Ala.: AU Press, July 1983), 89.

2 Mentioned during one of Carl Builder's many visits to Air University in support of the *Air Force 2025* study. Builder is a RAND analyst.

## ***Bibliography***

### **Books**

- Barnett, Jeffery R. *Future War: An Assessment of Aerospace Campaigns in 2010*. Maxwell AFB, Ala.: Air University Press, January 1996.
- Beaumont, Roger. *The Nerves of War*. Fairfax, Va.: Armed Forces Communications Electronics Association International Press, 1986.
- Builder, Carl H. *The Icarus Syndrome*. New Brunswick, N.J.: RAND, 1994.
- Bjorklund, Raymond C. *The Dollars and Sense of Command and Control*. Washington, D.C.: National Defense University Press, 1995.
- Campen, Alan D., ed. *The First Information War*. Fairfax, Va.: Armed Forces Communications Electronics Association International Press, October 1992.
- Coakley, Thomas P. *Command and Control for War and Peace*. Washington, D.C.: National Defense University Press, January 1992.
- Fuller, J. F. C. *Armament and History*. New York: Charles Scribner's and Sons, 1945.
- Generalship: Its Diseases and Their Cure*, Harrisburg, Pa.: Military Service Publishing Co., 1936.
- Gleick, James. *Chaos: Making a New Science*. New York: Penguin Books, 1988.
- Gordon, Michael R. and Bernard E. Trainor, *The Generals' War*. Boston: Little, Brown and Company, 1995.
- Howard, Michael and Peter Paret, ed. and trans. *Carl Van Clausewitz: On War*. Princeton, N.J.: Princeton University Press, 1976.
- Hughes, Daniel J., ed. *Moltke on the Art of War*. Novato, Calif.: Presidio Press, 1993.
- Hunt, James G. and John D. Blair, eds. *Leadership on the Future Battlefield*. London: Pergamon-Brassey's, 1985.
- Johnson, Stuart E. and Alexander H. Levis, eds. *Science of Command and Control: Part II*. Fairfax, Va.: Armed Forces Communications Electronics Association International Press, 1989.
- Keaney, Thomas A. and Eliot A. Cohen, *Gulf War Air Power Survey Summary Report*. Washington, D.C.: Department of the Air Force, 1993.
- Keegan, John. *The Mask of Command*. New York: Penguin Books, 1988.
- Levis, Alexander H. and Ilze S. Levis, eds. *Science of Command and Control: Part III*. Fairfax, Va.: Armed Forces Communications Electronics Association International Press, 1994.
- Mann III, Edward C. *Thunder and Lightning*. Maxwell AFB, Ala.: Air University Press, April 1995.
- Marshall, S. L. A. *Men Against Fire*. New York: William Morrow and Company, 1947.
- McNamara, Stephen J. *Air Power's Gordian Knot: Centralized Versus Organic Control*. Maxwell AFB, Ala.: Air University Press, August 1994.
- Naisbitt, John. *Megatrends*. New York: Warner Books, 1982.

- Nichiporuk, Brian, and Carl H. Builder. *Information Technologies and the Future of Land Warfare*. Santa Monica, Calif.: RAND, 1995.
- Orr, George E. *Combat Operations C<sup>3</sup>I: Fundamentals and Interactions*. Maxwell AFB, Ala.: Air University Press, July 1983.
- Puryear, Edgar F. *19 Stars*. Novato, Calif.: Presidio Press, 1971.
- Reynolds, Richard T. *Heart of the Storm*. Maxwell AFB, Ala.: Air University Press, January 1995.
- Schneider, Barry R. and Lawrence E. Grinter, eds. *Battlefield of the Future*. Maxwell AFB, Ala.: Air University Press, September 1995.
- Shultz, Richard H. and Robert L. Pfaltzgraff. *The Future of Air Power in the Aftermath of the Gulf War*. Maxwell AFB, Ala.: Air University Press, July 1992.
- Sullivan, Gordon R. and James M. Dubik. *War in the Information Age*. Carlisle Barracks, Pa.: US Army War College, 4 June 1994.
- Slim, William. *Defeat Into Victory*. London: Cassell and Company, 1956.
- Snyder, Frank M. *Command and Control: The Literature and Commentaries*. Washington, D.C.: National Defense University, 1993.
- Thibault, George E., ed. *The Art and Practice of Military Strategy*. Washington, D.C.: National Defense University, 1984.
- Toffler, Alvin, and Heidi Toffler. *War and Anti-War*. Boston: Little, Brown and Company, 1993.
- Van Creveld, Martin. *Command in War*. Cambridge, Mass.: Harvard University Press, 1985.
- The Transformation of War*. New York: The Free Press, 1991.
- Warden III, John A. *The Air Campaign*. Washington, D.C.: Pergamon-Brassey's, 1989.
- Winnefeld, James A., and Dana J. Johnson, *Joint Air Operations*. Annapolis, Md.: RAND, 1993.

### Articles

- Cohen, Eliot A. "The Mystique of U.S. Air Power." *Foreign Affairs*, vol. 73 (Jan/Feb 1994).
- Crecine, John P. and Michael D. Salomone "Organization Theory and C<sup>3</sup>I." In Stuart E. Johnson and Alexander H. Levis, eds. *Science of Command and Control: Part II*. Fairfax, Va.: Armed Forces Communications Electronics Association International Press, 1989.
- Hyde, John P., Johann W. Pfeiffer, and Toby C. Logan, "CAFMS Goes to War." In Alan P. Campen, ed. *The First Information War*. Fairfax, Va.: Armed Forces Communications Electronics Association International Press, October 1992.
- Kiszely, J.P. "The Contribution of Originality to Military Success." In Brian H. Reid, ed. *The Science of War*. London: Rutledge, 1993.
- Schmitt, John F. "A Concept for Marine Corps Command and Control." In Alexander H. Levis and Ilze S. Levis, eds. *Science of Command and Control: Part III*. Fairfax, Va.: Armed Forces Communications Electronics Association International Press, 1994.
- Schneider, Barry R. "Principles of War for the Battlefield of the Future." In Barry R. Schneider and Lawrence E. Grinter, eds. *Battlefield of the Future*. Maxwell AFB, Ala.: Air University Press, September 1995.
- Todd, Greg. "C<sup>1</sup> Catharsis." *Army*, vol 36 (February 1986).

Tuttle, Jerry O. "C<sup>3</sup>, An Operational Perspective." In Stuart E. Johnson and Alexander H. Levis, eds. *Science of Command and Control: Part II*. Fairfax, Va.: Armed Forces Communications Electronics Association International Press, 1989.

Vermillion, John M. "The Pillars of Generalship" *Parameters*, vol. 17 (Summer 1987).

Vincent, Gary A. "A New Approach to Command and Control: The Cybernetic Design." *Airpower Journal*, vol. 7 (Summer 1993).

### Documents, Studies, and Speeches

FAM 1-1, vol. 1, March 1992, and draft *Air Force Doctrine Document 1*, 15 August 1995. Washington, D.C.: Department of the Air Force.

Arquilla, John, and David Ronfeldt. "Cyberwar is Coming" (RAND Study P-7791, Air University Library, Document M-U 30352-16, no. 7791).

Boyd, John R. "A Discourse on Winning and Losing." A collection of unpublished briefings and essays, compiled from 1976–1992. Air University Library.

Fadok, David S. "John Boyd and John Warden: Airpower's Quest for Strategic Paralysis." Maxwell AFB, Ala.: Air University Press, February 1995.

Field Manual (FM) 100-5, *Operations*. Washington, D.C.: Department of the Army, 14 June 1993.

Fischer, Michael E. "Mission-Type Orders in Joint Air Operations." Maxwell AFB, Ala.: Air University Press, May 1995.

Fleet Marine Forces Manual (FMFM) 1-1, *Campaigning*. Washington, D.C.: Department of the Navy, 25 January 1990.

Fogelman, Ronald R. "Getting the Air Force into the 21st Century." Speech to the Air Force Association's Air Warfare Symposium, Orlando, Fla., 24 February 1995.

Joint Pub 0-2, *Unified Action Armed Forces*. Washington, D.C.: Joint Chiefs of Staff, 24 February 1995.

Joint Pub 1, *Joint Warfare of the Armed Forces of the United States*. Washington, D.C.: Joint Chiefs of Staff, 10 January 1995.

Joint Pub 3-0, *Doctrine for Joint Operations*. Washington, D.C.: Joint Chiefs of Staff, 1 February 1995.

Joint Pub 6-0, *Doctrine for Command, Control, Communications, and Computer (C<sup>4</sup>) Systems Support*, Washington, D.C.: Joint Chiefs of Staff, 30 May 1995.

Joint Warfighting Center, Warfighting Vision 2010, draft. Fort Monroe, Va.: Joint Chiefs of Staff, 1 August 1995.

Marshall, James P. "Near-Real-Time Intelligence on the Tactical Battlefield." Maxwell AFB, Ala.: Air University Press, January 1994.

Naval Doctrine Publication 1, *Naval Warfare*. Washington, D.C.: Department of the Navy, 28 March 1994.

Norwood, J. Scott. "Thunderbolts and Eggshells." Maxwell AFB, Ala.: Air University Press, September 1994.

Perry, William J. *Annual Report to the President and the Congress*. Washington, D.C.: Department of Defense, 1995.

Proceedings of the 1992 Symposium on Command and Control Research, held at Naval Post Graduate School, Monterey, Calif., 12–14 June 1992, and compiled by Science Applications International Corp., McClean, Va.

Sink, J. Taylor. "Rethinking the Air Operations Center." Maxwell AFB, Ala.: Air University Press, September 1994.



USAF Scientific Advisory Board. *New World Vistas: Air and Space Power for the 21<sup>st</sup> Century*.  
Unpublished draft, the Communications Volume. 15 December 1995.

**Joint Readiness Assessment and Planning Integrated Decision System  
(JRAPIDS):  
Combat Readiness and Joint Force Management for 2025**



A Research Paper  
Presented To

Air Force *2025*

by

Lt Col David M. Snyder  
Maj Penny J. Dieryck  
Maj Wesley W. Long  
Maj Thomas G. Philipkosky  
Lt Cmdr Ronald Reis

April 1996

## **Disclaimer**

*2025* is a study designed to comply with a directive from the chief of staff of the Air Force to examine the concepts, capabilities, and technologies the United States will require to remain the dominant air and space force in the future. Presented on 17 June 1996, this report was produced in the Department of Defense school environment of academic freedom and in the interest of advancing concepts related to national defense. The views expressed in this report are those of the authors and do not reflect the official policy or position of the United States Air Force, Department of Defense, or the United States government.

This report contains fictional representations of future situations/scenarios. Any similarities to real people or events, other than those specifically cited, are unintentional and are for purposes of illustration only.

This publication has been reviewed by security and policy review authorities, is unclassified, and is cleared for public release.

# Contents

<i>Chapter</i>		<i>Page</i>
	Disclaimer.....	ii
	Illustrations.....	iv
	Preface .....	v
	Executive Summary .....	vi
1	Introduction.....	1
2	JRAPIDS Capability.....	9
	New View of Readiness.....	9
	JRAPIDS Characteristics .....	11
3	Concept of Operations .....	14
4	System Description.....	19
	JRAPIDS Output.....	22
	Emerging Technologies .....	25
	Near-Instantaneous Personnel Assessment.....	25
	Smart Asset Reporting and Control.....	26
	Operational Modeling.....	27
	Advanced Training Techniques .....	31
	Functional Testing.....	32
	Overall Technologies .....	34
5	Investigative Recommendations.....	38
	Acronyms .....	40
	Bibliography.....	42

## Illustrations

<i>Figure</i>	<i>Page</i>
1-1. Current Readiness and Sustainability Assessments.....	3
1-2. Joint Readiness System .....	5
1-3. Joint Readiness Assessment Planning Integrated Decision System.....	7
3-1. Information Processing System.....	16
4-1. Joint Readiness Assessment Planning Integrated Decision System.....	20
4-2. JRAPIDS Readiness Matrix .....	23
4-3. Notional JFACC Output .....	24
4-4. Expert Systems Model.....	29

## *Preface*

In accomplishing this research, we received invaluable help from several individuals. We thank our faculty advisors; Col (Dr) Tamzy House of the Air War College and Maj George E. Spenser of Air Command and Staff College for their support throughout the project. Their patience, insight, and advice were invaluable. Not to be forgotten, we thank our families for their continued sacrifices and understanding during our absences.

Lt Col David M. Snyder

Maj Penny J. Dieryck

Maj Wesley W. Long

Maj Thomas G. Philipkosky

Lt Cmdr Ronald Reis

## *Executive Summary*

Leaders who organize, train, equip, command, and fight with the air and space forces of 2025 will require a new view of readiness. The current readiness reporting system provides a static snapshot that essentially reports the ability of a unit to accomplish 100 percent of its wartime tasking. The opportunity exists to create a new system for measuring readiness and sustainment, one that will provide military and civilian leaders a more comprehensive understanding of total force readiness and the potential trade-off benefits available.

*The nature of the world will allow, as well as demand, an integrated system for measuring, adjusting, and forecasting readiness and training that will provide the US military with a comparative advantage.* This system, called joint readiness assessment and planning integrated decision system (JRAPIDS), will automatically update the readiness status of individuals, units, and forces (active and reserve) while providing decision makers a comprehensive measure of readiness and sustainment that focuses on measurement at the output side of several interdependent modules. The final product consists of a time-variable, mission-scaleable matrix depicting capability available over time in a given theater for a given task or mission. The matrix provides a framework that allows decision makers overall force management capability. Finally, this paper suggests an incremental implementation plan for future JRAPIDS integration connected to potential technology development.

# Chapter 1

## Introduction

Military planners have long struggled to develop a system that ensures enough military capability exists, at any given time, to guarantee success across an increasingly broad range of operational missions. Each mission within this operational continuum requires a discrete set of capabilities derived from specific mission tasks. Looking to the future worlds of 2025,<sup>1</sup> this concept appears constant. In other words, as long as there exists a military force to accomplish the tasks assigned by the national command authorities (NCA), there exists a discrete and quantifiable amount of desired capability. Moreover, as long as this condition exists, there will be a need to accurately measure, analyze, and predict these desired capabilities against anticipated or actual requirements.

Future force capability requirements will likely center around effectiveness, efficiency, and flexibility. Preparation should begin today for possible future funding adjustments. Effectiveness and efficiency ensure the proper amount of funding for the correct amount of forces with the ability needed to cover all expected missions. Flexibility ensures existing forces can respond rapidly to all situations and conduct missions across the entire spectrum of conflict.

In characterizing the potential nature of future warfare, Lance Glasser, director of the Advanced Research Projects Agency, defined the importance of readiness to the future capability of US armed forces:

These will be fight-anywhere, fight-anytime wars, where “anywhere” and “anytime” will largely be defined by the enemy. The battlespace will be characterized by sudden and awesome lethality. The outcome will be determined in large part by the readiness of US forces to engage the enemy.<sup>2</sup>

Therefore, in the year 2025, the ability to accurately assess all aspects of the force’s operational capability will be critical. This assessment will necessarily include the ability to accurately predict changes



to the force's overall capability (when, what, and how much) and allow informed decisions regarding trade-offs among all competing priorities. The question then becomes, how will military capability be defined in the future?

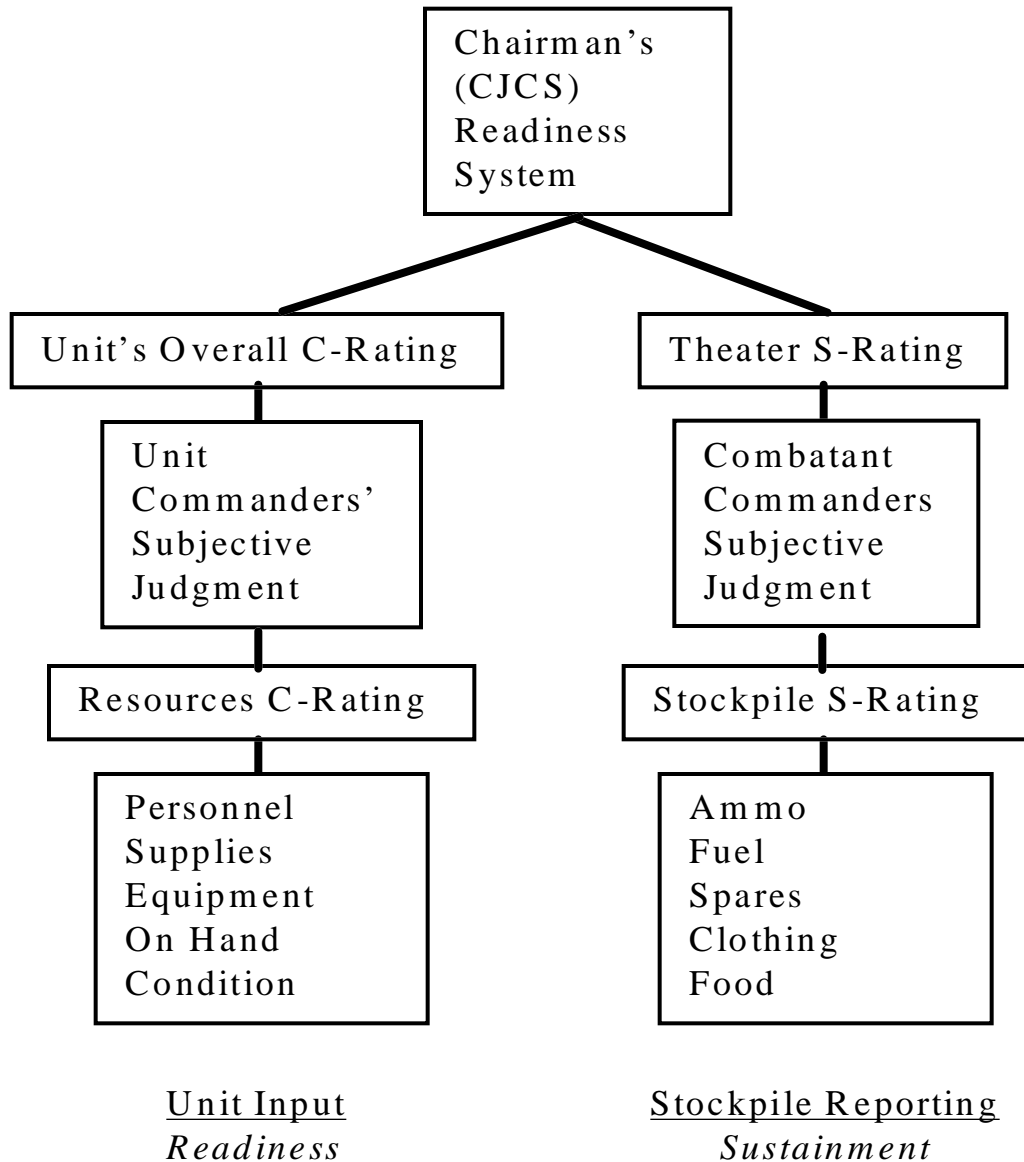
The Department of Defense currently defines military capability as consisting of four primary components:<sup>3</sup>

- Force Structure - numbers and composition of units and forces.
- Modernization - technical sophistication of the force as a whole.
- Readiness - ability of forces, units, weapon systems, or equipment to deliver their designed outputs. This includes the ability to deploy and employ without unacceptable delay.
- Sustainability - ability to maintain the necessary level and duration of operational activity to achieve military objectives.<sup>4</sup>

Within this construct, force structure and modernization establish the maximum force potential while readiness and sustainability enable (or constrain) the forces' ability to achieve their potential quickly (readiness) and over the long term (sustainment).<sup>5</sup> Several studies indicate that these basic notions will remain valid for the forces of 2025.<sup>6</sup> Therefore, gauging the overall capability of the future force will require assessment in each of these four areas. However, a logical breakpoint exists between assessing the factors of maximum potential (force structure and modernization) and assessing the primary enabling factors (readiness and sustainment). This paper focuses on the latter of these areas, readiness and sustainment.

The current readiness and sustainment assessment method focuses on inputs and/or the availability of specific reserves or conditions from two separate and distinct sources, the service and the combatant command. Figure 1-1 depicts the current system. As shown, the status of resources and training system (SORTS) reflects current levels of military readiness. SORTS generalizes a unit's military readiness based on the lowest rating in five areas. Most commanders view the SORTS C-Rating (its measure of current readiness) as a report card of whether the unit can accomplish its wartime mission at its designed operating capability (DOC). Using this method, mission tasks (and the training requirements they generate) are essentially static and commanders have little ability to redirect resources in the short term for contingency operations. For sustainment, stockpiled assets are given an S-Rating. In this system the combatant commander in chief (CINC) prepares a periodic report that includes an objective tally of the amount of the theater war reserves available (pre-positioned and out of theater) based on the operation plan (OPLAN) requirements and a subjective overall S-Rating for his area of responsibility.<sup>7</sup> The only assessment of output

(desired capability) in both methods relies too much on the subjective judgment of commanders and decision makers based on inputs they receive. Limited data available, private agendas,<sup>8</sup> faulty interpretations, and other human frailties ensure an assessment fraught with potential inconsistencies and inaccuracies thereby potentially leading to ineffective and wasteful force management.<sup>9</sup> Furthermore, because of the disconnect at lower levels, C-Rating and S-Rating do little to convey the true capabilities of the military at the unit, joint force, and national level.



**Source:** Compiled from the ideas of the referenced sources: Moore, et al., vii.

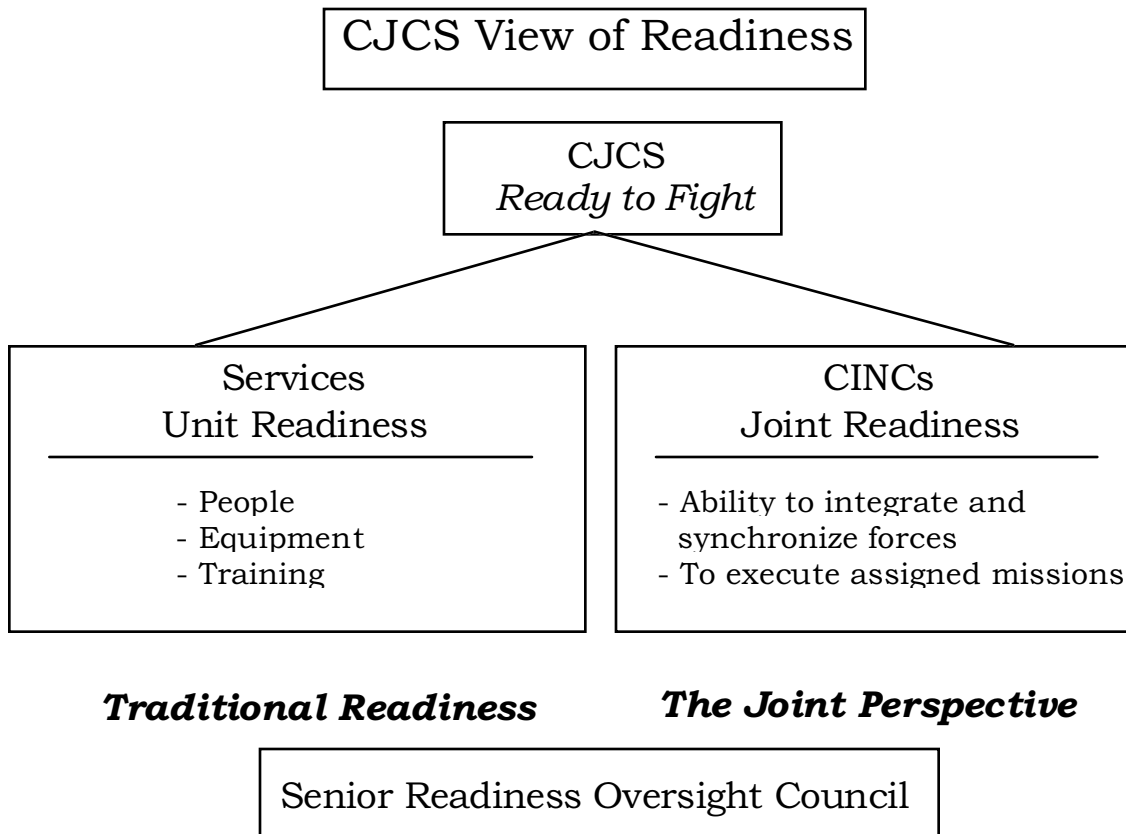
**Figure 1-1. Current Readiness and Sustainability Assessments.**

An upgrade to SORTS was recently implemented and renamed global status of resources and training system (GSORTS).<sup>10</sup> This system communicates SORTS data over the Global Command and Control System (GCCS). These ongoing improvements to the current methods as well as to the next generation of readiness and sustainment assessment methods, such as in *Joint Vision 2010*,<sup>11</sup> still fall short of providing an accurate and predictive measure of joint force military capabilities at all levels.<sup>12</sup> As shown in Figure 1-2, military readiness assessment still relies on stovepipe reporting as well as considerable subjective input. Stovepiping in this context refers to the lack of information cross-flow between the two systems. This lack of integration limits the quality of decisions regarding trade-offs between competing priorities.

These systems also rely heavily on subjective input. Subjective evaluation of the line commander is an important element of a useful reporting system, but the manipulation of subjective readiness evaluations for political or other noncombat purposes must be minimized. Gen Michael Carns (USAF, retired) points out that the current readiness system is utilized by commanders, staff officers, and politicians to fight resource allocation battles.<sup>13</sup> Dr Richard Kohn also highlights these complex ethical issues, and corresponding implications for civil-military relationships. He believes today's military leaders and civilian decision makers are faced with a unique set of sociocultural problems when attempting to measure and assess military readiness objectively.<sup>14</sup> Richard Betts devotes an entire chapter to similar issues in his 1995 book, *Military Readiness: Concepts, Choices and Consequences*.<sup>15</sup> He notes the hazards associated with proposing new systems for measuring readiness.

It should not be surprising that administration and services always had an excuse when they were criticized for allowing readiness to decline, or that critics adopted the same excuses when they moved into positions of authority themselves. The typical techniques for deflecting criticism were to deny the validity of criteria cited by critics, to conflate conflicting criteria, or to change the criteria by revising the official rating system.<sup>16</sup>

However, since this paper concerns the development of a system to measure readiness in 2025, these political and social implications are outside its focus.



**Source:** Compiled from data presented by Gen John M. Shalikashvili to the House Committee on National Security, 25 January 1995.

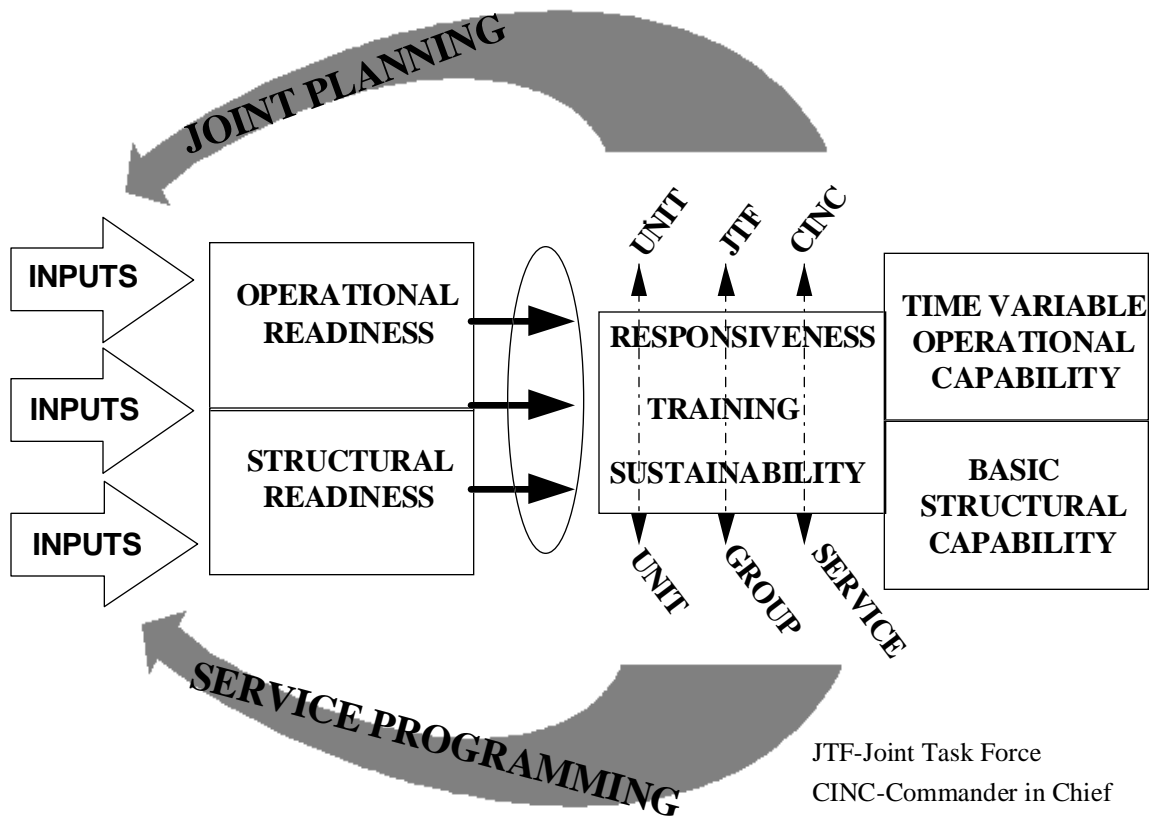
**Figure 1-2. Joint Readiness System**

Although the variables affecting the possible alternate futures of 2025 are numerous, several constants exist that affect overall military capability. First, achieving the most military capability at the lowest overall cost will continue to be an important goal of any defense planning system.<sup>17</sup> The cost issue is a critical point since military combat capability is called upon only intermittently and paying for high levels of continued but unused readiness is expensive.<sup>18</sup> Second, historically, the American public has displayed a low tolerance for large standing military forces, especially when the perceived threat is low.<sup>19</sup> Third, all of the factors currently affecting readiness and sustainability will continue to affect military capabilities in the future. Finally, as American defense policy changes, choices affecting the capability of military forces will be necessary to meet the variable requirements of the ever-changing security environment.

The opportunity exists to develop a new system for assessing and predicting the capability of air and space forces of 2025 that will fulfill the demands of all potential future worlds. Key emerging technologies allow for the development of a system that integrates readiness, sustainment, and operational training not only to measure objectively, but also to forecast, as well as adjust, military capabilities at the unit, joint force, and national levels. This paper proposes the development of the joint readiness assessment and planning integrated decision system, shown in Figure 1-3, as a framework for integrating these emerging technologies into a holistic method for determining future force capabilities.

The key to JRAPIDS is that it focuses on the output, or desired capability, of the total force versus merely tabulating the condition and availability of resources. Moreover, it provides a seamless, time-variable, and mission-scaleable measure of merit for the enabling portion of overall military capability (readiness and sustainment) applicable to all forces, including both the active and reserve component. The potential political battles over the validity of any readiness criteria are well understood; however, the key advantages of the JRAPIDS concept, “verisimilitude and verifiability,”<sup>20</sup> far outweigh these potential concerns.

This paper develops the required capabilities of JRAPIDS and defines the key components and concept of operations. It also identifies key future technological concepts and validates them for system inclusion. Finally, it presents a road map for JRAPIDS integration.



**Figure 1-3. Joint Readiness Assessment Planning Integrated Decision System**

Before discussing actual capabilities, it is important to note three key assumptions made during the journey to the future to determine JRAPIDS requirements. First, air and space forces of the future will require sufficient capabilities to operate across the entire spectrum of conflict. Second, computing power in 2025 will become virtually unlimited.<sup>21</sup> The ability to perform data computation, transmission, or storage will not be constrained. Finally, efficiency, effectiveness, and flexibility will remain primary drivers for force management in any conceivable future environment.<sup>22</sup>

**Notes**

<sup>1</sup> Col Joseph A. Engelbrecht Jr., PhD, et al, “Alternate Futures for **2025**: Security Planning to Avoid Surprise” (unpublished white paper, Air War College, Air University, Maxwell AFB, Ala., 1996).

<sup>2</sup>Lance A. Glasser, “Today’s Technology Begets Tomorrow’s Military Readiness,” Internet address <http://www.au.af.mil>, *ARPA Press Release*, 1 February 1995.

<sup>3</sup> Craig S. Moore, J. A. Stockfish, Mathew S. Goldberg, Suzanne Holyrod, and George G. Hildebrandt, *Measuring Military Readiness and Sustainability*, RAND Report R-3842-DAG, ( Santa Monica, Calif.: RAND, September 1991), 2.

<sup>4</sup> Armed Forces Staff College Publication One, *The Joint Staff Officer's Guide, 1993* (Norfolk, Va: National Defense University, Armed Forces Staff College) 6–11.

<sup>5</sup> Moore et al., 4.

<sup>6</sup> Ideas generated from the following publications: Air University, *SPACECAST 2020: The World of 2020 and Alternate Futures* (Maxwell AFB, Ala.: Air University Press, June 1995), 10; *Forward From the Sea* (Washington, D.C.: Department of the Navy, January 1995), 9. *Army Focus: Force XXI* (Washington, D.C.: Department of the Army, January 15, 1995), 10.

<sup>7</sup> Ibid., 18.

<sup>8</sup> Gen Michael P. C. Carns, USAF, Retired, advisor comment on **2025** Team Y JRAPIDS white paper (Maxwell AFB, Ala.: Air War College/**2025**, 25 March 1996).

<sup>9</sup> Richard K. Betts, *Military Readiness: Concepts, Choices, Consequences* (Washington, D.C.: The Brookings Institution, 1995), 43.

<sup>10</sup> Maj Jeff Fink, Headquarters USAF/XOOR, telephone interview with Lt Col David M. Snyder, 4 April 1996; and Col James N. Worth, USAF/USACOM, J-32 Readiness Division, telephone interview with Lt Col Snyder, 5 April 1996.

<sup>11</sup> Joint Chiefs of Staff white paper, “Joint Vision 2010 America’s Capability: Shaping the Future,” undated, telephone facsimile provided by Headquarters USAF/XOXS, 29 January 1996.

<sup>12</sup> Lt Col Charles R. Rash, US Army, “Joint Readiness Evaluated,” US Army War College thesis (Carlisle Barracks, Pa.), April 1995, 3.

<sup>13</sup> Carns.

<sup>14</sup> Dr. Richard Kohn, advisor comment on **2025** Team Y JRAPIDS white paper (Maxwell AFB, Ala.: Air War College/**2025**, 25 March 1996).

<sup>15</sup> Betts, 115–43.

<sup>16</sup> Ibid., 132.

<sup>17</sup> Lt Cmdr Leslie S. Turley, US Navy, “The Impact of the Defense Budgeting Process on Operational Readiness” (Monterey, Calif.: Naval Post-Graduate School, March 1993), 16.

<sup>18</sup> Betts, 43.

<sup>19</sup> Ibid., 24.

<sup>20</sup> Col Richard Szafranski, USAF/AWC, assessor comment on **2025** Team Y JRAPIDS white paper (Maxwell AFB, Ala.: Air War College/**2025**, 25 March 1996).

<sup>21</sup> Scientists present differing views on whether this assumption is valid for the world of **2025**. We agree with several AF **2025** lecturers and Nicholas Negroponete, *Being Digital* (New York: Knopf, 1995). They stated that computational, storage, and transmission capability will not be a limiting factor in **2025**. JRAPIDS requires a quantum leap in this capability, but it does not require an unlimited capability.

<sup>22</sup> Lt Gen Jay W. Kelley, USAF, “Brilliant Warrior” (Unpublished paper, Air University, Maxwell AFB, Ala., February 1996), 4.

## Chapter 2

### JRAPIDS Capability

#### New View of Readiness

Before discussing JRAPIDS requirements, it is essential to fully define readiness for the force of 2025. Describing this new view, Richard Betts divides readiness into two categories, structural and operational.<sup>1</sup> Structural readiness is the foundation or basic level of capability that is enhanced by investment. Operational readiness is a consumable level of military capability that focuses on specific, short-term aspects of unit and aggregate status, equipment, and training levels.<sup>2</sup> JRAPIDS integration will require adopting this comprehensive view of readiness as well as taking into account the required training needed to achieve the optimum mix of readiness.

This view is essential to the comprehensive picture of overall capabilities that will be provided by JRAPIDS. Readiness is not a binary “yes or no” issue; instead, it is a matter of how much, what kind, how soon, and at what cost, including the corresponding opportunity costs. In other words, it should incorporate “fuzzy logic.”<sup>3</sup> As Betts accurately points out, “The main question for policy and strategy should not be how to achieve readiness in any single sense. Rather, it is how to integrate or balance the answers to the following questions over a long period of time.”<sup>4</sup>:

- Readiness for when? How long to “ready”?
- Readiness for what? “Ready” to perform what tasks?
- Readiness for where? “Ready” for what theater or combat environment?<sup>5</sup>



The critical dimension of readiness, sustainment and training is time. In theory, future military forces can prepare for any type of contingency if they are provided enough time and resources. Realistically, resource and training time will be finite. The measurement of the amount of training time required to prepare for a particular task is an appropriate 2025 element of readiness. Thinking about and measuring readiness in the time dimension allows for relevant comparisons between levels of readiness and an understanding of the trade-off equation. The trade-off equation seeks an appropriate balance between immediately available capability and capability available at a later time thus allowing readiness preparations for other missions or tasks. Finally, the time aspect of readiness is most relevant if it deals with specific military tasks or missions.

This leads to the second dimension of a future view of readiness, specifying the task for which an individual or unit should be prepared. Training to do the right task is essential; it minimizes wasted effort, expenses, and potential capability deterioration.

The final component of readiness is training to do the proper task in the right place. This generally means in a particular environment, geographic theater, or specific military medium (e.g., space, low altitude, permissive air environment, etc.).

Operational readiness of an individual, weapon system, unit, or force (aggregation of several units) should be thought of as a matrix where preparedness to accomplish specific military tasks in specific environments is measured in units of time needed to prepare for the task. For the air and space forces of 2025, optimal readiness need not always mean being immediately ready (preparation or training time equals zero) for 100 percent of the required tasks in all possible environments. A constant state of maximum readiness is costly and highly perishable. The future view of readiness must include (1) a comprehensive understanding of the type of training necessary; (2) the time available to prepare a unit for specific tasks; and (3) a corresponding understanding of key trade-offs and missed opportunities.

This new view of readiness must focus on the outputs of readiness, sustainment, and training in an integrated manner, rather than the unmeshed inputs of each (as the current system does). The key to future air and space force readiness lies in understanding the readiness trade-offs available. As previously discussed, trade-offs, in this context, occur when the decision makers decide on the correct level and type of training that yields the optimal readiness for specific operational tasks. Within the unit, the trade-off decision must be

made between all of the tasks that are constantly competing for the available readiness, sustainment, and training resources. At the joint force level, the trade-off decision must be made between units. The proper readiness mix is essential. For example, a notional unit that had a high level of readiness (zero or minimal training time needed) in nearly all assigned OPLAN tasks may represent an inappropriate trade-off among resources if the threat is low. Finally, the readiness trade-off decision may also require a balance of investment among the various components of military combat capability as well as within each component.

### **JRAPIDS Characteristics**

From the preceding discussion it becomes apparent that the effective management of the joint air and space forces of **2025** demands an output-focused, integrated systems approach to readiness assessment to obtain the optimal readiness combination of when, what, and where. As shown in Figure 1-3, JRAPIDS will assess, judge, and predict the impact of all factors in the following areas:

- Responsiveness - the promptness in preparing for the task at hand.
- Operational training - flexible training in the field that allows for preparing for new tasks in new environments.<sup>6</sup>
- Sustainability - required endurance in performing a particular military task.

JRAPIDS provides a new approach to readiness and sustainability measurement with a new set of components and processes. It is necessary to first determine the unconstrained requirements for the proposed system and then provide an assessment of the potential risks associated with developing the needed technology. The RAND study, *Measuring Military Readiness and Sustainability*, is the primary source for many of the following characteristics of an “ideal” readiness and sustainment system:<sup>7</sup>

- Measurement of Output - JRAPIDS must measure unit and force capability as a function of time versus merely computing assets on hand. It will answer the question, “readiness and sustainability for what?” JRAPIDS must be capable of assessing actual performance levels of all resources within the unit and it must provide an aggregate, scaleable performance indicator for the unit as whole. It must also be able to provide an overall performance potential assessment for joint and national level forces.
- Practical - JRAPIDS must be easy to use and inexpensive to operate. Said another way, “The job of measurement should stay extremely small compared with the jobs of providing readiness and sustainability.”<sup>8</sup> Moreover, the information provided by JRAPIDS must be easily understood and easily interpreted by all users and decision makers, throughout the chain of command.
- Objective - JRAPIDS must be objective and verifiable to ensure accurate measurements. A few subjective judgments will still be required for personal insights such as morale levels or any other judgment requiring a high degree of human intuition. The key is that these should be limited in order to lessen the impact of incorrect assessment. Furthermore, system protocols should prevent

penalties for lower-level commanders whose readiness levels are low for reasons beyond their control. This also imbues an attitude of truthful assessment.

- Robust - JRAPIDS must be capable of assessing readiness and sustainability across a wide range of contingency operations and real-world circumstances thus allowing accurate measurements in the face of unforeseen events. It must also assess readiness levels at all times, whether the unit is deployed or not. This implies the requirement for real-time or near-real-time update capability.<sup>9</sup>
- Useful - JRAPIDS must provide useful feedback to the lowest level of data providers. Units must be able to determine if actions taken to correct shortfalls have positively affected readiness rates. Additionally, the system must tailor the output to each level of command. For instance, the information required by a joint force commander is different from that required by a service component commander. One caution is in order here. Due to the complex nature of this system and the existence of this feedback loop, decision makers must ensure the effects of chaos do not impede system operation.<sup>10</sup>
- Comparable - JRAPIDS must be capable of providing objective comparisons of readiness and sustainment levels from one year to the next. This allows decision makers to base effective trade-off decisions on factual historical data rather than on subjective assumptions.
- Comprehensive - JRAPIDS must be able to assess peacetime activity rates of resources and relate them to military operational ability. The intent is to accurately predict the resource implications during the transition from peace to war. This also allows the continuous monitoring of the effects of peacetime operating tempo (OPTEMPO) and personnel tempo (PERSTEMPO) on operational readiness and combat sustainability.
- Secure - As a global information system possessing critical data on US military capabilities, JRAPIDS will be a prime target in any future information war.<sup>11</sup> Therefore, system security will be an essential requirement.
- Trade-off Evaluation - JRAPIDS must allow trade-off comparisons between resource categories as well as between the categories of military capability. The intent is to provide a system that can identify when too much emphasis in one area adversely impacts other areas of military capability. A key feature of JRAPIDS will be the assessment of the impact to the overall force's capability as units are deployed, in transit, or redeployed.

These “ideal” characteristics provide the objective requirements for the future system. We understand that various constraints, such as funding, may limit their practical application. Nonetheless, we have used the unconstrained characteristics to guide the development of the JRAPIDS concept of operations.

## Notes

<sup>1</sup>Richard K. Betts, *Military Readiness: Concepts, Choices, Consequences* (Washington, D.C.: The Brookings Institution, 1995), 35–84.

<sup>2</sup>Ibid., 40–43.

<sup>3</sup>Lewis J. Perelman, *School's Out* (New York: Avon Books, 1995), 33.

<sup>4</sup>Betts, 32–33.

<sup>5</sup>Ibid., 33.

<sup>6</sup>It is important to note that training discussed in this paper is operationally oriented towards a particular mission or task and is distinctly different than the general education and training espoused by Maj Laura DiSilverio et al, in “Brilliant Force” (unpublished 2025 white paper, Air University, Maxwell AFB, Ala., 1996).

<sup>7</sup>Craig S. Moore, J. A. Stockfish, Mathew S. Goldberg, Suzanne Holyrod, and George G. Hildebrandt, *Measuring Military Readiness and Sustainability*, RAND Report R-3824-DAG (Santa Monica, Calif.: RAND, September 1991), 23.

<sup>8</sup>*Ibid.*, 23.

<sup>9</sup>In this context, near-real-time refers to rapid updates and assimilation of data into useful information. It is understood that this will never occur instantaneously due to physical limitations. However, the term is used to add emphasis to the need for speed.

<sup>10</sup>Maj Glenn E. James, "Chaos Theory: The Essentials for Military Applications," in *Air Command and Staff College Theater Air Campaign Coursebook* (Maxwell AFB, Ala.: Air Command and Staff College, 1995), 33.

<sup>11</sup>James W. McLendon, "Information Warfare: Impacts and Concerns," *Battlefield of the Future: 21st Century Warfare Issues* (Maxwell AFB, Ala.: Air University Press, September 1995), 189.

## Chapter 3

### Concept of Operations

The JRAPIDS concept of operation promulgates ideas for improving the measurement of readiness, training, and sustainability throughout the total force. The feasibility of developing and operating such an assessment framework is encouraging due to the fact that several of its elements already exist today—for instance, the new GSORTS which transmits readiness data through the global command and control system and all logistics feasibility models already in use. Moreover, the possibility exists of an incremental implementation process into the current DOD readiness reporting infrastructure.

For decision makers, JRAPIDS would become the foundation of their military assessment tools by providing a real-time cost-versus-benefits analysis. At the strategic and operational level, the system would incorporate a revised readiness, training, maintenance, logistic, and personnel reporting process that would enable the user to:

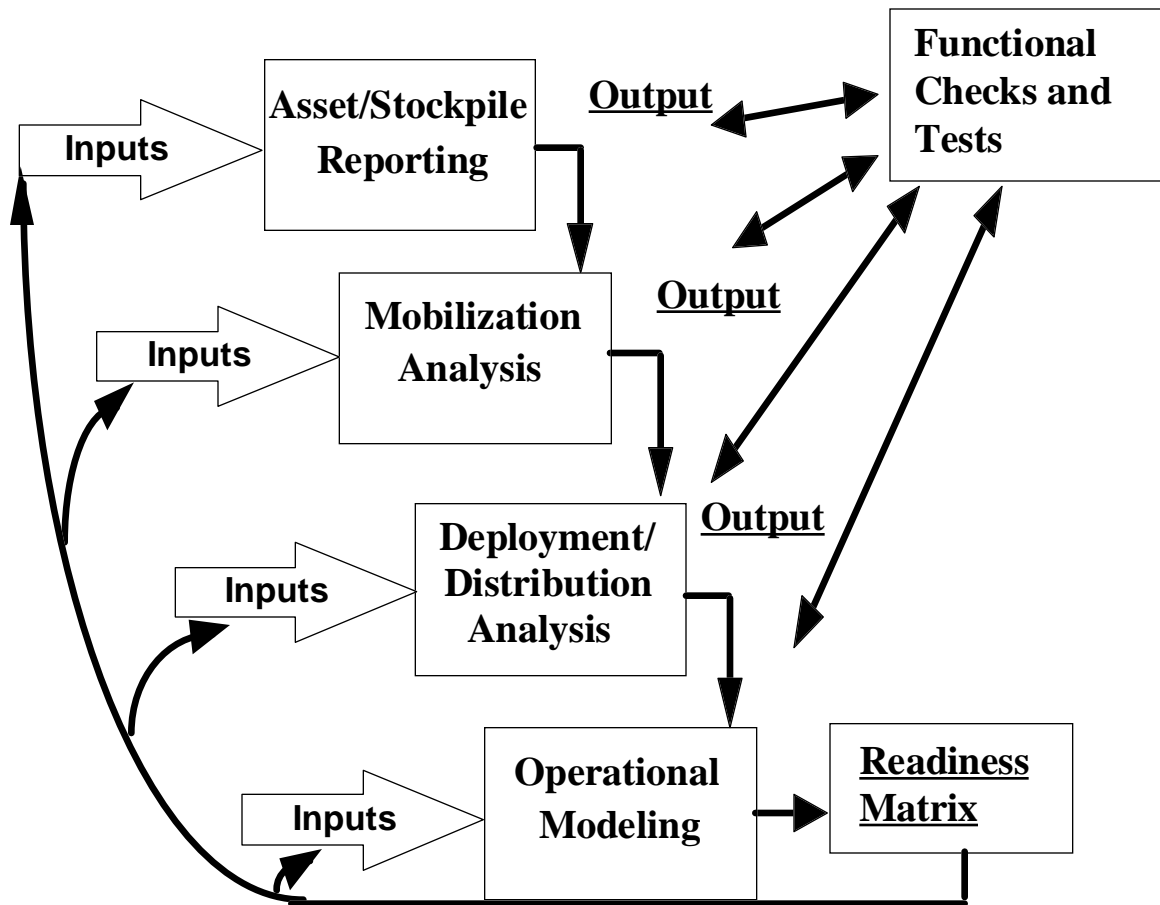
- Access real-time information about fielded forces or unit-level strengths and weaknesses while interfacing with the joint operation planning and execution system or its replacement system, in order to enhance potential war-gaming scenarios.
- Forecast training and readiness timetables tailored to specific mission types in specific combat environments or theaters as defined in various sources such as the CINCs' operation plan (OPLAN) or the joint universal lessons learned system (JULLS).
- Identify inventory trends and potential shortfalls while showing percentages of nonmission-capable equipment due to supply and/or maintenance problems.
- Predict the effects that downsizing or “correct” sizing of material or personnel or changing funding would have on force structure and overall future readiness; also provide this information to the future equivalent of the planning, programming, and budgeting system (PPBS) and JOPES to shape future force readiness.

Using JRAPIDS, units actually deployed or preparing for deployment would maintain a very high degree of readiness in their tasked missions. Units (active and reserve component) not actively involved in deployment preparation, or those units with additional time available (due to OPLAN or other mission

constraints) would become more cost effective by maintaining a minimum baseline level of readiness until specific requirements arise. Once these units were needed, specific mission requirements would drive a tailored operational training program. Sources for specific mission requirements would be the NCA, OPLANs, contingency plans (CONPLANs), functional plans, JULLS, or any other pertinent mission-specific database. The actual tasks and requisite performance specification would come from the future equivalent to the joint minimum essential task listing (JMETL).<sup>1</sup> All units would be capable of:

- Prioritizing unit level and individual training requirements with ongoing maintenance and personnel status reports in order to minimize training time for specific operational commitments.
- Adapting mission or task training programs to accommodate the most current operational “lessons learned.” For example, early deployers could provide information useful to late deployers through the future equivalent of JULLS.
- Maintaining optimal readiness of ongoing immediate missions and tasks such as space surveillance, missile warning, and combat alert.

As our military forces ebb and flow into the twenty-first century, the trade-offs, most notably capabilities versus cost, will continue to play a major role in our overall force composition.<sup>2</sup> All military services will strive to deliver more “bang for the buck.” Due to its focus on the output side and its total integration of operational training, readiness, and sustainment, a fully implemented JRAPIDS would provide such direct benefits as increased readiness and training connectivity throughout all areas of the military. Also, decision makers would have the ability to see directly the effect of different funding patterns on force capabilities, readiness, and sustainability.



**Source:** Craig S. Moore, J. A. Stockfish, Mathew S. Goldberg, Suzanne Holyrod, and George G. Hildebrandt, *Measuring Military Readiness and Sustainability*, RAND Report R-3842-DAG (Santa Monica, Calif.: RAND, September 1991), 98.

**Figure 3-1. Information Processing System**

The foundation of an integrated readiness, training, and sustainability assessment framework begins by formulating and then integrating all eclectic aspects of our current military infrastructure. This requires the seamless integration of modular systems through a highly computerized system linked by a world-wide net with real-time, or near-real-time information access for all users. Borrowing from the concept developed by Moore et al., JRAPIDS would include the following modular systems: *asset and stockpile reports*, *mobilization analysis*, *deployment and distribution analysis*, *operational modeling*, and *functional checks and tests*.<sup>3</sup> Figure 3-1 depicts each of these modules and their relationship within JRAPIDS.<sup>4</sup>

- Asset and Stockpile Reports - This module collects data on unit assets, supply stockpiles, reserve manpower, and all unit training requirements. It then transforms that data into useful information, reporting the condition of all of the unit's needed resources and unit train-up times for the specific task or mission.<sup>5</sup> As shown, this output provides additional input to the next module.

- Mobilization Analysis - This module takes data collected on force mobilization (induction and training capacities) and industrial mobilization (industrial production and service capacities) and ties these to the timing objectives and priorities established for the mission. This information, along with the input from the previous module, is used to establish the actual availability of units, manpower, and materiel that could become available over time and the changing levels of unit capability attainable (the latter mainly through “training up”).<sup>6</sup>
- Deployment and Distribution Analysis - This module takes into account storage, handling, and movement of all things necessary to accomplish the tasks assigned to the units, or joint forces. It takes the information from the previous module and translates it into profiles of the numbers of combat units, support units, and materiel that could be available at appropriate locations in combat theaters.<sup>7</sup> It also includes the effects of increasing lift and handling capacities at various civil reserve air fleet (CRAF) activation levels to allow the maximum flexibility in mobilization planning.
- Operational Modeling - This module converts the profiles from the previous module into the time-variable, mission-scalable performance levels available at the desired operating location.<sup>8</sup> Assumptions, estimates, and empirical data gathered on the performance requirements for the specific mission would form the input to the various models.
- Functional Checks and Tests - This module would provide a significant feedback loop between each module as well as provide a way to estimate or verify all of the inputs, all of the outputs, and all of the time-capability relationships used throughout the system.<sup>9</sup>
- Feedback - Although not a module per se, feedback at all levels of the system, as well as between components, is absolutely critical. The effects of such feedback will provide the ability for “on-the-fly” corrections to ongoing training or readiness preparations.

The successful integration of each of these interdependent modules requires the further development of several technologies. It is important to note these emerging technologies, shown below grouped into six functional categories, were chosen because they provide the highest degree of leverage against the previously discussed JRAPIDS requirements.

- Near Instantaneous Personnel Assessment - Technologies that allow near-real-time, detailed assessment of personnel-related readiness data. These technologies stress the human side of the readiness equation and are important to all modules within the proposed system.<sup>10</sup>
- Smart Asset Reporting and Control - Technologies that allow real-time, detailed accounting and assessment of equipment-related readiness data. These technologies stress the machine side of the readiness equation and are also important to all modules within the proposed system.<sup>11</sup>
- Operational Modeling - Varying degrees of modeling exist throughout the system. The key technologies needed in 2025 include real-time human modeling and aggregate modeling for predicting unit level performance. This is the most critical module in the system and possibly the most risky for successful technology integration.
- Advanced Training Techniques - Operational training possesses a discrete value in the readiness equation; therefore, better, faster training means higher readiness. The key technologies needed for this system include all forms of virtual training in a distributed and simulated environment.<sup>12</sup>
- Functional Testing - The output nature of the proposed system demands performance-based functional testing at the output side of all modules within the system. The needed technology must assess individual and aggregate unit performance in a real-time, objective, and nonintrusive manner.<sup>13</sup>
- Overall - Several technologies are needed to provide the connectivity, information security, and overall integration of the system. These technologies are key to providing a seamless system as viewed by all users.<sup>14</sup>



The key to successful JRAPIDS integration lies in each of these enabling technologies. Therefore, these technologies are discussed in detail following a description of JRAPIDS in the next chapter.

## Notes

<sup>1</sup> John R. Ballard and Steve C. Sifers, "JMETL: The Key to Joint Proficiency," *Joint Force Quarterly* no. 9 (Autumn 1995), 95.

<sup>2</sup> USAF Scientific Advisory Board, *New World Vistas: Air and Space Power for the 21<sup>st</sup> Century*, summary volume (Washington, D.C.: USAF Scientific Advisory Board, 15 December 1995), 5.

<sup>3</sup> Craig S. Moore, J.A. Stockfish, Mathew S. Goldberg, Suzanne Holyrod, and George G. Hildebrandt, *Measuring Military Readiness and Sustainability*, RAND Report R-3842-DAG (Santa Monica, Calif.: RAND, September 1991), 96.

<sup>4</sup> *Ibid.*, 97.

<sup>5</sup> *Ibid.*, 87

<sup>6</sup> *Ibid.*, 89

<sup>7</sup> *Ibid.*, 92

<sup>8</sup> *Ibid.*, 94

<sup>9</sup> *Ibid.*, 95

<sup>10</sup> **2025** Concepts, No. 900175, "Virtual-reality Trainers," No. 900516, "Generation X Theater Level Combat Simulation;" No. 200004, "Advanced MILSATCOM Capabilities," No. 20007, "Rehearsal For All Missions, in a Mission Media, without Vehicle Movement," No. 900454, "On Line Satellite Link for Medical Records for Deployed Personnel," No. 900523, "Chip in the Head," No. 900559, "Thumb Implanted Individual Identification Codes," **2025** Concepts Database (Maxwell AFB, Ala.: Air War College/**2025**, 1996).

<sup>11</sup> **2025** Concepts, No. 200019, "Smart Packages," No. 900323, "Bar Code Readers in Space;" No. 900335, "Worldwide Military Cellular Phone System," Concept No. 900367, "Enhanced Defense Readiness by Logistics Integration," No. 900413, "Wireless Local Area Network," No. 900609, "Smart Tools," No. 900611, "Smart Parts" No. 900672, "Integrated Logistical Battlespace Sustainment," **2025** Concepts Database (Maxwell AFB, Ala.: Air War College/**2025**, 1996).

<sup>12</sup> **2025** Concepts, No. 200007, "Rehearsal in All Missions, in a Mission Media, Without Vehicle," No. 900175, "Virtual-reality Trainers," No. 900516, "Generation X Theater Level Combat Generation Simulation," No. 900534, "Virtual Force **2025**," No. 900629, "VR for Cultural Competence," No. 900643, "On Platform Initial Flying Training," and No. 900680, "Holographic Meetings," **2025** Database (Maxwell AFB, Ala., Air War College/**2025**, 1996).

<sup>13</sup> **2025** Concepts, No. 900334, "De-Massification of Response," No. 900484, "Functional Reorganization," No. 900700 "The Flat Air Force," **2025** Concepts Database (Maxwell AFB, Ala.: Air War College/**2025**, 1996).

<sup>14</sup> **2025** Concepts, No. 200004, "Advanced MILSATCOM Capabilities," No. 900131, "Security," No. 900138 "Secure Communications on Demand," No. 900182, "Neuro-Network Computer Interface," No. 900183, "Computer Security," No. 900184, "Automated Security," No. 900290, "Artificial Intelligence," No. 900329, "Human Friendly Design," No. 900561, "Data Bus Information Pull Computers," No. 900669, "Database Sharing," **2025** Concepts Database (Maxwell AFB, Ala.: Air War College/**2025**, 1996).

## Chapter 4

### System Description

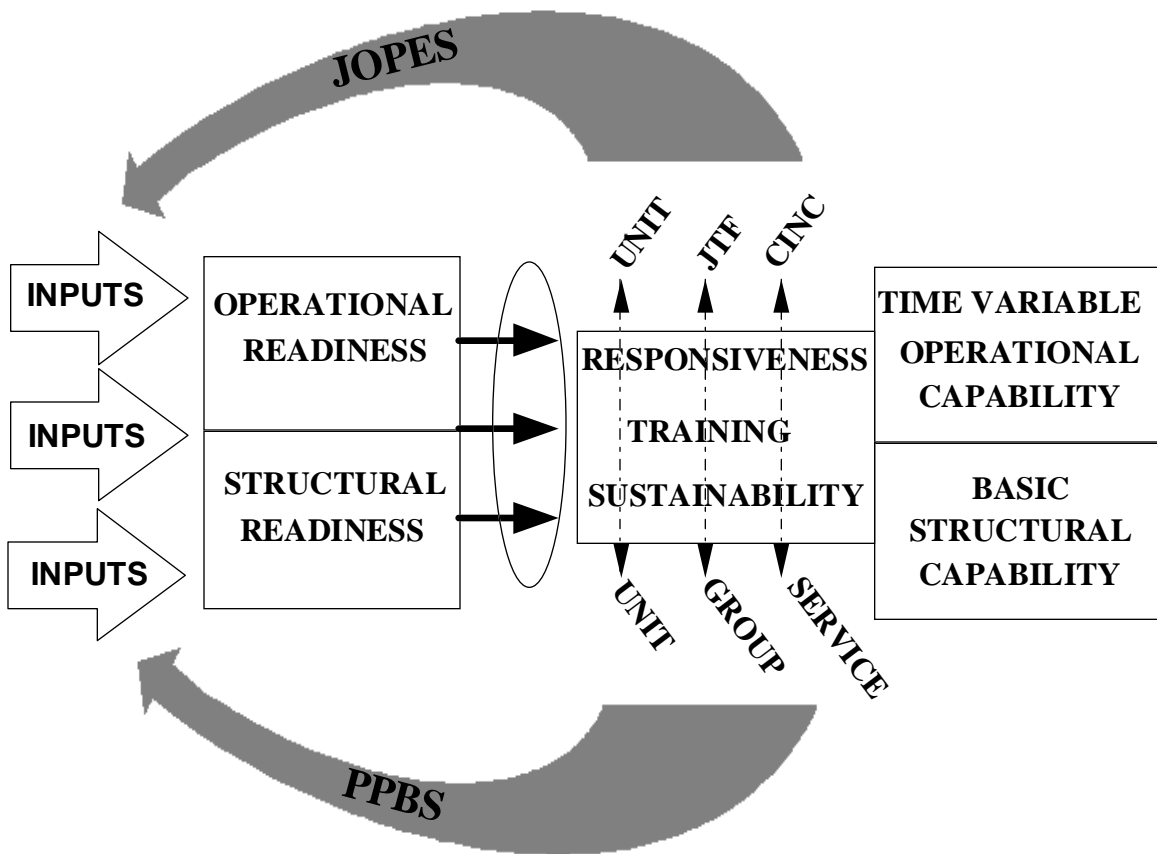
By the year 2025, the joint readiness assessment and planning integrated decision system will provide a time-variable, mission-scaleable, cost-effective means of managing US forces' overall readiness and sustainment levels. Today, due to timing constraints and system inadequacies, a notional F-16 squadron trained to conduct close-air-support (CAS) operations may find itself operationally deployed to conduct air-to-air operations. In the future, JRAPIDS will provide the CINC with near-real-time information on each unit's readiness state thereby minimizing such a problem.

JRAPIDS also will provide commanders at all levels with the most efficient and cost-effective means of maintaining a baseline level of proficiency (i.e., structural readiness) pending specific mission identification. In theory, JRAPIDS will be capable of identifying the time needed to achieve a particular readiness level for a given task. Unit commanders could then maintain some individuals or equipment at lower states of readiness based on available preparation time. Once the specific tasks are established, JRAPIDS would then identify any type of performance weakness and provide a tailored training or preparation program.

Military forces contain two stages of readiness, structural and operational. The foundation of JRAPIDS exploits this premise. Structural readiness concerns mass; it is about how soon a requirement-sized force can be available.<sup>1</sup> It also refers to (1) the number of personnel under arms with at least a basic level of training; (2) the number of organized formations, including the quantity and quality of their weapons; and (3) the distribution of combat assets among land, sea, air, and space power. Structural readiness establishes the limits of organized capability in existing forces and potential capabilities in nonexistent forces. This begins

with procurement and includes the amount of time it takes to produce a new asset, system, basic level of training, or unit from scratch.

Operational readiness is different. According to Betts, “Operational readiness is about efficiency and is measured in terms of how soon an existing unit can reach peak capability to fight in combat,”<sup>2</sup> or in our case, perform an operational task. It indicates how proficiently a unit may perform a given task, but not how successful it may be. In 2025, operational readiness must become more objective and comprehensive. JRAPIDS will build on the current assessments of operational readiness by including operation tempo and personnel tempo effects, mobility limits, exercise schedules, command control communications computer and intelligence (C<sup>4</sup>), morale states, contingency types, and contingency duration.<sup>3</sup>



**Figure 4-1. Joint Readiness Assessment Planning Integrated Decision System**

Figure 4-1 depicts the relationships among inputs, feedback loops, and potential users that would constitute JRAPIDS. Inputs vary, but would consist of unit asset reporting and theater stockpile reporting. In

principle, these reports would be nearly the same as today. JRAPIDS would continue to use this information to guide resource allocations within the services. The JRAPIDS integrated framework would continue to use the raw counts of specified resources in different locations and conditions. Other inputs would be more performance oriented. For example, in the system's final configuration, an F-16 pilot could fly a simulated CAS mission over Bosnia. During the event, the computer would evaluate the pilot's performance and directly factor it into the squadron's overall readiness state.<sup>4</sup>

Next, analysis of mobilization potential would project the additional quantities of personnel, materiel, and units that could become available over time. To project the numbers of different kinds of units that could be prepared over time, planners would need a time-phased resource allocation model. This would include (1) the scope of all resources available for the mobilization; (2) the assets (equipment, manpower, and materiel) needed to conduct the mission and unit train-up times, developed using data from step one; (3) the capacities of mobilization activities (i.e., induction centers, specialist training schools, staging areas, and unit training ranges); and (4) the timing and priorities pertinent to the contingency being analyzed. Cumulatively, the time-phased resource allocation model will help guide the allocation of limited resources and provide the in-depth time-phased analysis that is needed today.<sup>5</sup>

Deployment and distribution analysis will address the movement, handling, and storage of all equipment, manpower, and material from premobilization locations to areas of use. It would estimate the quantities of units and materiel of different types that could be in place in the area(s) of interest over time.

Operational modeling would convert information about available units and support resources and information concerning operations (e.g., employment patterns and corresponding expenditure and attrition rates) into profiles of the mission activity levels that could be achieved. The assumption here is that a series of models will be used to predict the amount of readiness available over time. The key to this is accuracy. Therefore, each model must rely on the most robust set of estimates and assumptions available and on the technology to convert them into capabilities.<sup>6</sup> With this in mind, this module becomes the most ambitious and risky in terms of future technology and successful system integration. It is assumed that as technology matures, so will this module. Therefore, the impact of simplistic modeling estimates becomes a constant yet workable problem within the system.

Finally, functional testing would be designed to summarize the results in ways useful to decision makers. It will also provide key feedback between modules as well as data on exercises and tests that will provide crucial information for training, lessons learned, and performance improvement. JRAPIDS provides feedback through a joint planning system, currently the joint operations planning and execution system (JOPES) from unit level, joint task force (JTF) level, and commander in chief (CINC) level. Readiness feedback at the various command levels is also provided through a service programming system, currently the programming, planning, and budgeting system (PPBS). The ability to develop integrated assessments will be within the capability of systems in the year 2025.

### **JRAPIDS Output**

The JRAPIDS output will be designed around an information “pull” concept similar to the currently emerging “mission pull” long-range planning system.<sup>7</sup> An example of the potential JRAPIDS output for a notional airlift squadron is shown in Figure 4-2. This is just one possible representation of a readiness and training matrix that would be available to the commander of an airlift squadron. In this example, the notional 1st Airlift Squadron (which very well could have been reporting C-1 or C-2 under the current GSORTS) is represented by the complex relationship among the minimum training times needed to make the squadron ready to perform specific OPLAN tasks in specific theaters and environments.

As shown in Figure 4-2, readiness is reported as a function of time—in this case “days.” It indicates the number of days required to prepare for a specific task in a particular environment or theater. The time element could be displayed in hours, days, weeks, months or even years, although the most common measure should be days.

1st Airlift Squadron (NOTIONAL) 16 PAA	Basic	Aerial Refueling	Formation Refueling	Heavy Equipment Airdrop	Personnel Airdrop	SKE Formation	Visual Formation	Precision Approach	Nonprecision Approach	CAT II Approach	Emergency Nuclear Airlift	Chemical Warfare
	<b>OPERATIONAL</b>											
Pacific Theater	X	4	15	10	12	11	6	0	6	6	0	0
European Theater	X	4	15	10	12	11	6	0	4	6	0	0
SWA Theater	X	4	16	10	12	11	6	2	12	12	0	0
SOUTHCOM Theater	X	4	16	10	12	11	6	2	12	12	0	0
Northern Latitudes	X	X	16	10	12	11	6	2	12	12	0	0
Low Level	X	X	X	10	12	11	6	0	4	0	X	X
Middle Altitude	X	4	16	X	20	11	6	0	4	0	X	X
High Altitude	X	X	X	X	11	12	2	8	0	X	X	X
Night	X	8	16	15	18	11	15	2	6	6	X	X
Day	X	4	15	10	12	11	6	2	0	6	X	X
VMC	X	4	15	10	12	11	6	2	0	6	X	X
IMC	X	8	16	15	18	11	X	2	6	6	X	X
<b>STRUCTURAL</b>												
Survival Training	0	X		X	X	X	X	X	X	X	X	X
Ground Training	4	X		X	X	X	X	X	X	X	X	X
Instrument Qual	8	X		X	X	X	X	X	X	X	X	X
Basic Qual	0	X		X	X	X	X	X	X	X	X	X
<p align="center"><b>JRAPIDS Notional Unit (Airlift Squadron) Readiness Matrix</b></p> <p align="center">Numbers Represent Days of Training Needed to Meet JMETL Requirements</p> <p align="center">X = Task or Environment Not Applicable or Required</p> <p align="center">SKE = Station Keeping Equipment for formation flight in weather</p> <p align="center">SWA = Southwest Asia; SOUTHCOM = US Southern Command</p> <p align="center">VMC = Visual Meteorological Conditions; IMC = Instrument Meteorological Conditions</p>												

Figure 4-2. JRAPIDS Readiness Matrix

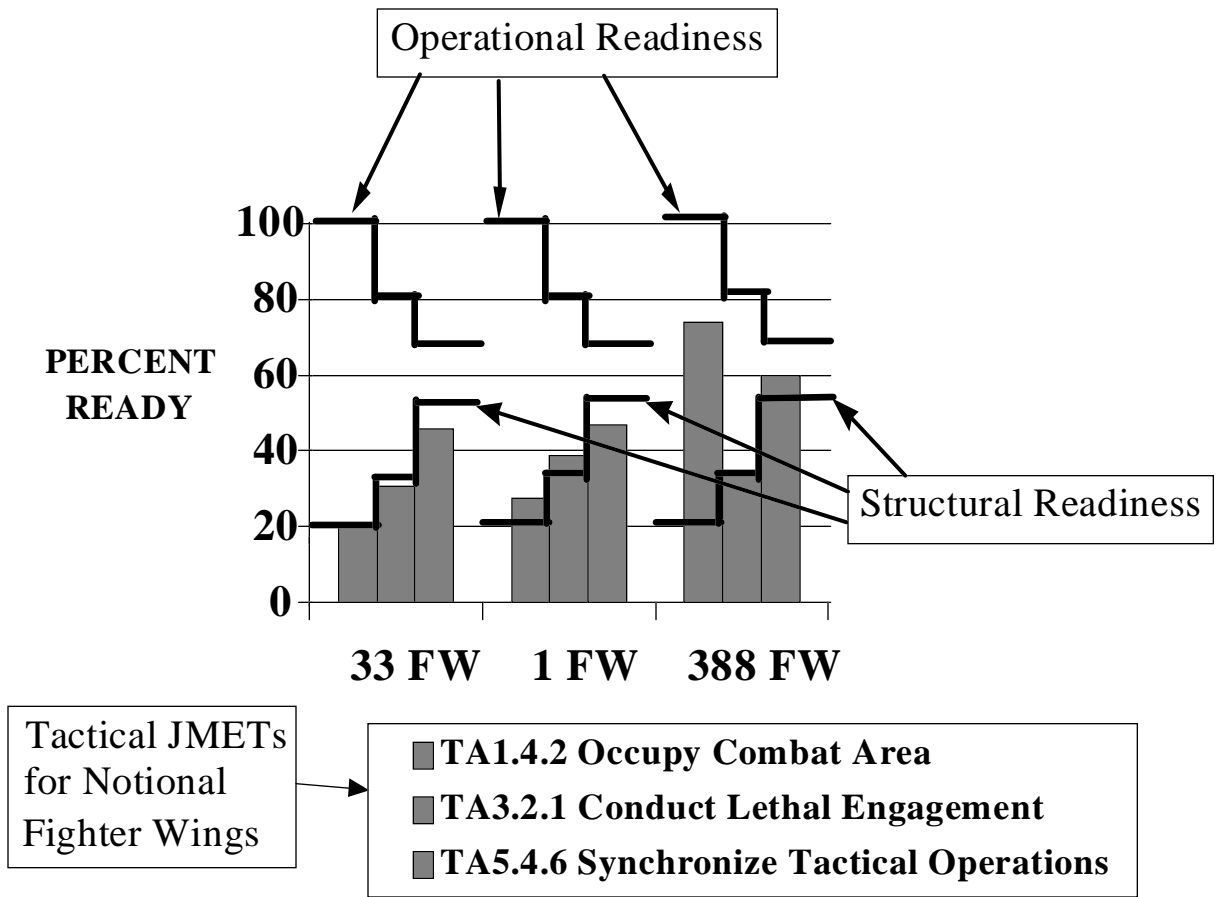


Figure 4-3. Notional JFACC Output

JRAPIDS output will be tailored to the level of the decision maker requiring the information. Figure 4-3 shows another possible example of JRAPIDS output. In this case, the information is provided to the joint forces air component commander (JFACC). As shown, individual tasks (joint minimum essential tasks) from the JMETL provide the essential requirements for the given mission. For this representation, the time element is derived from the difference between the unit's actual readiness states and the JFACC's desired operational readiness level shown in the upper template.

Through the use of expert systems and sophisticated visualization techniques, information will be presented to each decision maker in a manner that will optimize human understanding and comprehension of force readiness available. The particular needs of each level of decision maker, as well as for each service, will be factored in so that each is only seeing the information needed or requested. For instance, the level of detail needed by an Army division commander may be significantly different from that of the joint chiefs of

staff (JCS) or a joint task force commander. JRAPIDS will account for this difference and adjust accordingly.

## **Emerging Technologies**

As previously mentioned, several key technologies require further development to ensure the future integration of JRAPIDS. This section addresses these technologies in detail. It attempts to define the present technological state while validating all submitted concepts and to show potential bridging technologies from today's world to the world of 2025.

### **Near-Instantaneous Personnel Assessment**

The importance of people to the readiness equation cannot be understated, according to Lt Gen Jay W. Kelley: "People are the most valuable and critical element in the armed forces."<sup>8</sup> Although this will remain true in the year 2025, the methods used to prepare individuals for positions and contingencies will be vastly different. The key to the procedures for near-instantaneous personnel reporting will be the connectivity and networking of computer systems and programs into a comprehensive, user-friendly database.

Near-instantaneous personnel assessment will be conducted via interlinked computer software in 2025. People will be tracked via a "photobook" face verification system. These are computer-accepted prints of an individual's face generated by working with a fixed set of facial images and treating them as one huge matrix of information. The computer finds the main features in its database and combines them to form one face.<sup>9</sup> Each individual face print is unique. This is a superior method of identification to fingerprints and/or a computer bar code. As individuals complete phases of training or readiness preparation, they input the data into the JRAPIDS using their face prints.

A key aspect of the future may include the placement of a microprocessor chip into an individual's brain. A person can learn by uploading information through a wireless high-bandwidth connection that interfaces with the "chip." This should improve efficiency and accuracy from 5 to 10 percent to 95 to 100 percent.<sup>10</sup> Also, effective intuitive display formats will be developed requiring the human to rely on artificially displayed information.<sup>11</sup> Finally, to ensure all personnel are meeting training requirements and



operational capability standards, JRAPIDS will allow instantaneous update of personnel records, on-the-job training records, or other pertinent personnel data sources.

### **Smart Asset Reporting and Control**

As stated earlier, future military capability will rest heavily on the concept of “just in time” readiness levels. Reaching this level of sophistication will require a new philosophy of asset and inventory management. The philosophy will center on automatic data collection (ADC), real-time tracking, and continuous automatic self-health monitoring of all of the various pieces of equipment (including the human) needed to effectively execute the unit’s tasked mission throughout the deployment, employment, and redeployment cycle. The estimated savings gained by employing a just-in-time inventory control system range in the neighborhood of \$4 to \$5 billion dollars a year by current-day assessments.<sup>12</sup> The following section explores the processes and identifies the key enabling technologies.

The suggested process template borrows from the commercial sector’s quick response (QR) inventory management philosophy in use today. QR entails shortening the cycle time from raw material to finished product at the retail outlet while reducing inventories at every level of manufacturing and distribution. Current-day QR tactics include bar coding, collecting data in the distribution pipeline through scanning, and automatically transmitting data by electronic data interface (EDI).<sup>13</sup> A discussion of each follows.

By 2025, every piece of equipment will be bar coded (or otherwise electronically tagged) for inventory management and control. Bar coding parts, assemblies, bins, pallets, tools, and other items, in conjunction with automatic scanning, provides for computerized tracking systems and automatic readiness reporting.<sup>14</sup> This technology currently includes radio frequency identification (RFID) tags that allow remote transmission of discrete data of each-bar coded item. With advances in cellular satellite communications, future applications would incorporate cellular transmitters that could allow worldwide satellite tracking and automatic readiness reporting, in real time, throughout the unit’s entire deployment to redeployment cycle.<sup>15</sup>

While bar coding provides the input data, EDI provides the output information. EDI includes all systems that capture the data provided by the scanned items, provide the analysis, and conduct the integration necessary to turn data into useful information.<sup>16</sup> Future computing power is the key to a seamless EDI

environment that eliminates error and provides real-time readiness information at all levels within the chain. For example, EDI could provide continuous assessment of all consumables in a unit's mobility readiness spares package (MRSP). Captured data could be analyzed to determine such things as actual use rates versus predicted total days of sustainment based on use rates, and it could automatically provide resupply information, including the order itself. An indirect benefit of EDI is that it automatically captures data that may be useful in other nonreadiness applications, such as fault reporting.<sup>17</sup>

Readiness ADC of the future will also include integration of existing computerized fault reporting systems (CFRS). The CFRS concept provides accurate generation of maintenance of fault-reporting codes in some of today's aircraft.<sup>18</sup> Conceptually, all future weapon systems will include this capability. Therefore, it will be crucial to attain the compatibility of all CFRS with the EDI architecture to ensure seamless integration. Furthermore, it will be important to build small, self-contained fault-reporting integrated chips for systems without CFRS. For example, a chip placed on a piece of equipment with a time-critical inspection cycle could self-report maintenance requirements or forecast potential problems. Given the current direction of microelectromechanical systems, this technology seems likely in the year 2025.<sup>19</sup>

Finally, the previous discussion begs the question, "Where do we go from here?" Bridging the technology gap from today until 2025 demands emphasizing the QR mentality, developing and adapting bar-coding techniques to military applications, and acquiring EDI equipment, for the entire DOD, with a jointly recognized standard architecture and process. The USAF's "lean logistics" concept provides one example of a potential template for future integration of all of these technologies.<sup>20</sup> According to Morrill, lean logistics is a system of innovations that promotes combat capability. Although its emphasis is on supply and inventory control, it establishes an architecture that can be adapted to readiness reporting requirements at all levels. For instance, it contains the need for an EDI structure to support its analysis requirements. The challenge for the future will be the adaptation of these concepts, processes, and equipment to the readiness realm.

### **Operational Modeling**

A critical technological link essential to JRAPIDS is operational modeling. Operational modeling captures the complex relationships among the many inputs and outputs providing predictive capabilities

throughout the system. These inputs include unit dependencies (mobility and support requirements); operational objectives and priorities (prioritized military tasks for specific environments); mission resource requirements (present and forecast); and the rates of utilization, attrition, preparation, and restoration.<sup>21</sup> The ability to model these relationships precisely will require enormous computing, artificial intelligence (AI), and modeling capabilities. Hence, this becomes one of the key technological risks to successful system integration in the future.

Perhaps the most important difference in our concept of readiness modeling is the ability to predict future readiness based on the variable of time rather than just measuring current readiness. According to the Government Accounting Office, in late 1993 the Air Force developed a computer model to forecast readiness.<sup>22</sup> This project, named Ultra, was intended to model and “measure four major elements of readiness: 1) the ability to deploy the right forces in a timely manner to achieve national objectives; 2) the ability to sustain operations; 3) the personnel end strength, quality, and training of people; and 4) the availability of facilities.”<sup>23</sup> The goal of the project was to forecast future readiness based on various funding levels. This one-year demonstration project met with limited success, due in part to its low funding (\$100,000).<sup>24</sup> Several military organizations have developed readiness models including the Army’s Blacksmith model, USSTRATCOM’s Prism model, and USACOM’s joint readiness automated management system (JRAMS).<sup>25</sup>

JRAMS is a three-year (\$1.5 million per year funding), OSD sponsored advanced concept technology demonstration (ACTD) project which is showing great promise.<sup>26</sup> While the system is still in the demonstration stage and only halfway through its three-year cycle, it represents a major initiative to model readiness of future forces. According to a USACOM J-32 Readiness Division briefing:

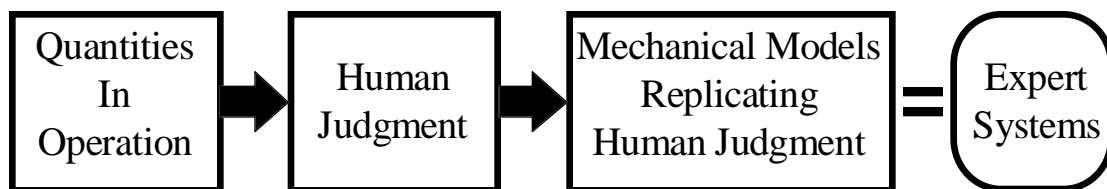
JRAMS is being developed to depict joint forces readiness by compiling and displaying readiness information from disparate databases using an objective architecture. This allows high-level planners to access the current availability and preparedness of any combination of forces or supplies.

JRAMS permits the rapid display of multiple scenarios and allows the user to quickly change from viewing one potential course of action to another. Users can rapidly switch between a graphical (pipes) view, a geographical (map) view, and a text (spreadsheet) view of the data. Every time a user requests an update on force readiness, JRAMS queries the appropriate databases, assimilates the data and performs calculations, then updates the information on the display.

Data used to determine joint readiness must come from a variety of sources. At the present time, JRAMS is directly importing information from two sources: the GSORTS and time phased force deployment data (TPFDD). Presently the project is expanding its access to other relevant databases to provide increased fidelity on joint readiness.<sup>27</sup>

JRAMS's promise has led to its use as the foundation technology to provide the modeling engine for the JCS automated joint monthly readiness review (AJMRR) with \$4 million dollars of funding.<sup>28</sup> This represents an important step in the development of a comprehensive readiness model in 2025. Thus the next step in fielding JRAPIDS has already begun to be put in place. The demonstrated JRAMS technology used in the AJMRR is being incorporated into the new \$40 million joint automated readiness system (JARS) being developed by contractors for the Joint Staff J-3.<sup>29</sup> These modeling systems represent critical investment in enabling technologies needed to fulfill the vision of JRAPIDS.

The modeling technology needed for the military forces of 2025 will not only require the ability to accurately forecast based on a myriad of input variables, but it will also require that these variables are automatically updated with verifiable data. The data updates must include a wide variety of information, such as utilization rates (wear and tear on equipment), OPTEMPO/PERSTEMPO (stress on personnel and equipment), command and control ability, and the impact of revised training programs. Modeling crucial intangibles allows real-time understanding of future capability. Real-time empirical data on operational experience must be factored into the models to allow rapid revision of the model and the training regime that prepares this unit and other units to operate under new conditions. For example, experience gained from flying missions in Bosnia must be quickly fed back to the readiness model and to the operational training profile conducted in theater as well as to other units preparing (increasing readiness) for operations in Bosnia, thus increasing readiness. Figure 4-3 points out the critical link in producing truly expert systems is the ability to replicate human judgment.<sup>30</sup>



**Source:** Col Richard Szafranski, USAF/AWC, assessor comment on 2025 Team Y JRAPIDS white paper (Maxwell AFB, Ala.: Air War College/2025, 25 March 1996).

**Figure 4-4. Expert Systems Model**

Modeling of the human mind will be a technical requirement to portray the effect of training programs on individual and unit performance. Equipment, displays, and tasks should be designed to give the human operators a conceptual picture of how specific operational tasks should be performed.<sup>31</sup> Proper human modeling and engineering will provide for safe, efficient, and high-quality operations.

The modeling algorithms must be able to aggregate individual and unit readiness into an accurate assessment of force readiness and sustainability. The readiness and sustainability of the military force are much more than the sum of each unit's readiness. A comprehensive readiness assessment includes modeling of intangibles such as leadership, morale, human performance, and interaction with other military units and capabilities. Improved human modeling also will permit superior screening and selection of military personnel for specific tasks.<sup>32</sup>

Combat modeling and wargaming do not presently address the impact of readiness and sustainability.<sup>33</sup> Jeffrey Cooper of Science Applications International Corporation (SAIC) expresses a very pessimistic view of the current state of combat models because: (1) no models accurately capture the nonlinear nature of combat; (2) most models are not sensitive enough to capture the effects of time-dependent factors such as temporal compression on combat outcomes; (3) current models do not work well with sparse battlespace and distributed forces operating in maneuver; (4) most models have difficulty integrating joint forces; and (5) existing models have difficulty capturing C<sup>4</sup>I information.<sup>34</sup> Based on Cooper's experience with the JCS exercise Nimble Vision, he states that

The current modeling capabilities are at best irrelevant, and at worst, a positive hindrance in understanding our real future needs in developing new operational concepts, in modifying command structures and organizations, in selecting new systems, and in determining future force structure requirements.<sup>35</sup>

The current measures of merit (e.g., forward edge of battle area (FEBA) movement and attrition of enemy forces or weapons) may not matter in future military operations. In addition, new measures of value must incorporate future war concepts such as information dominance.<sup>36</sup> An accurate model of readiness depicts the ability to accomplish a wide variety of military and political objectives.

Competence in operational modeling is a requirement for this new ability to measure trade-offs between readiness and sustainability or other pillars of military capability. This new concept for the air and space

forces of 2025 hinges on the ability to rapidly, accurately, and thoroughly model the complex dynamics of military operations in order to forecast readiness.

### **Advanced Training Techniques**

The technological advancements requiring development include distance learning, distributed education, and virtual simulation. Education will continue to evolve to the point that students learn through “experience” more than through conventional study.<sup>37</sup> Formal training and advanced degrees will be obtained via distributed virtual-reality (VR) discs and/or via the next generation internet as a form of distance learning. Enhancing professional military education is an additional application area for distributed training and virtual-reality technologies.<sup>38</sup> This capability for easily accessible and just in time learning is critical to the success of the redefined operational readiness.

The air and space forces of 2025 will conduct training via virtual-reality computers to rehearse movements to high threat locations.<sup>39</sup> The idea behind VR is to deliver a sense of “being there” by giving at least the eye what it would have received if it were there and, more importantly, to have the image change instantly as “experiences” change their point of view.<sup>40</sup> A readily deployable virtual-reality environment is the key developing technology for the training requirements demanded by JRAPIDS.

VR doesn't require a major breakthrough in software or in our understanding of how the brain works. Like the dynamics of the Wright Brothers' plane—the wings, motor, and steering—all the major components of VR already work. Continuing the industry's growth is mostly an issue of delivering graphics at higher resolution for less money. Where we go with VR is more important than how we build it, and our lack of understanding about how it will affect us and our civilization is the bigger mystery.<sup>41</sup>

The simulation network (SimNet) is a good example of current virtual-reality capabilities and military applications.<sup>42</sup> The system desired for our purposes would be an enhancement of SimNet with increased speeds, improved graphics, increased mobility and reduced costs. Training enhancements made possible through technological strides in VR will have broad applications, from combat-environment simulation to emergency room training; the limits appear bounded only by lack of imaginative application.<sup>43</sup>

## Functional Testing

The most distinctive feature of the proposed readiness system is that it measures output, or capability, to provide a time-variable and mission-scaleable level of readiness for the individual, unit, or force as a whole. Functional testing at the output side of each module is essential to this ability. The testing primarily provides a measure of actual performance levels of personnel, parts, equipment, or processes. It corrects or validates the output data from each module as it becomes input data to the next. Finally, it measures the final product from the operational modeling module and provides a feedback loop to each module, allowing for “on the fly” corrections or long-term process and product improvement. Key features of the functional testing module include:

- Fully automatic data collection and analysis for real-time, continuous, and adaptive assessment of all performance measurements.
- Individual and aggregate performance assessment that includes the ability to combine units to determine total force readiness levels.
- A high degree of objectivity with the ability to identify, label, track, and associate appropriate weighting to all sources and types of subjective inputs.

The following discussion focuses on these testing requirements for a few of the modules within the system and emphasizes the technologies that represent the most likely bridge from today’s world to the world of 2025.

Central to the functional testing module is the ability to collect, analyze, adapt, and assess all of the various performance measurements needed to ascertain operational capability. There is an underlying assumption that capability can be determined by collecting and analyzing a discrete set of metrics. Cox and Sever validated this concept.<sup>44</sup> Systematic requirements and decision maker preferences will determine the metrics chosen. These metrics will more than likely be derived from sources such as the successor to the current OPLANs and JMETL. Using electronic data integration as the primary backdrop, metric data will be automatically and continuously collected, analyzed, and assessed against the requirements established by the metrics. The capability inherent in expert systems of the future will allow the system to adapt the requirements of the metrics as necessary to give the fullest representation of available capabilities.<sup>45</sup> For example, as the pilot flies in the simulator, his actions are constantly judged against the set criteria for each task. His time required to train to a particular task decreases as his proficiency increases. For equipment, items such as time in maintenance (over a set number of days) or scheduling effectiveness would be examples

of the desired output of the testing system. All levels of the analysis information for both the individual and the aggregate group will be readily accessible to provide the highest degree of feedback thus allowing for correction and long term planning.

The functional testing module will provide a picture of capabilities for individual parts and pieces as well as for the whole unit or force. Individual assessment seems straightforward and has already been discussed in detail. Unit and force assessment will be more elusive and will call for the ability to assess performance levels of all elements during all types of force employment exercises. The system will automatically pull data from several sources including various employment exercises (like today's National Training Center or Red Flag), distributed VR simulated exercises, and lower levels of training (such as formation flying against a static target on a gunnery range). This data will be integrated with data from individual and lower-level assessments and analyzed to provide a time-variable assessment of the unit's, or force's, task-readiness state for the given element of the process. Once again, this information will be available to all levels of authority to provide an adequate feedback loop.

The ability to test individuals and determine an aggregate measure of the force's operational readiness becomes essential if "demassification" (or flattening of hierarchical organizations) becomes a reality in 2025. In this environment, the performance of the "organic whole" becomes dependent on the ability of each individual unit that makes up this "whole."<sup>46</sup> Thus, JRAPIDS will be operable in all organizational structures of the future.

Central to JRAPIDS is objectivity. ADC and EDI will enable a very high degree of objectivity since human intervention for data collection or assessment will not be required (in its final form). However, some elements will remain untestable. Therefore, subjective assessment will probably remain a requirement for those few items in 2025, particularly those dealing with the human side of the readiness equation. The strength of the system lies in its ability to identify the source of subjective data and provide a true weighting by either limiting or increasing its value based on the validity of the input. For example, a unit commander's subjective assessment of a unit's morale would be weighted higher than a joint force commander's assessment of the same unit since the unit commander has a better feel for his/her unit's morale.



## Overall Technologies

Technologies requiring development that will impact various segments of this readiness system include artificial intelligence and neural networking. Neural networking is critical to all human-computer interfaces within the training system. It is also key in determining one's own personal readiness and level of training. As of 1990, a neural network architecture had been developed which displayed promise for emulating human behavior and performance.<sup>47</sup>

It is based on a multi-layer, feed-forward architecture, but has a more complex architecture. The hidden layer has recursive connections that allow the network to emulate reaction time. The architecture also includes multiple sets of feed-forward connection weights. These different weights are trained and used under different situations to emulate different strategies. This makes the overall system a hybrid neural network expert system.<sup>48</sup>

One application for neural networking is in the virtual-reality world. Advancements in this area will enable future warriors to train against intelligent and real-time reactive virtual warriors. The Information Sciences Institute has already created "computer agents capable of matching wits with top human jet-fighter pilots in simulated dogfights conducted in virtual computer environments."<sup>49</sup>

Artificial intelligence includes the endeavor to build a smart computer. The machines should be capable of solving problems it has never encountered before, learning from its mistakes, and surviving in its environment.<sup>50</sup> The desire is for a computer to think as effectively as a human but much more efficiently. "Early AI developers assumed that what was easy for a human to do would also be easy for a computer. But it turned out to be the opposite. A computer can do things that are very hard for people, such as complex mathematics. But skills a two-year-old has mastered, such as recognizing a face or an object on a plate, has been a 40-year struggle for AI systems."<sup>51</sup> The failure of artificial intelligence in the past has been blamed on the inability to transfer prerequisite knowledge to the computer. According to Lenat, "Many of the prerequisite skills and assumptions have become implicit through millennia of cultural and biological evolution and through universal early childhood experiences."<sup>52</sup> Researchers in Austin, Texas, have made strides in this area of teaching the computers. This project is nearing the level "at which it can serve as the seed from which a base of shared knowledge can grow."<sup>53</sup>

Assessing readiness and developing training to specified readiness levels requires more than AI. It requires the ability to enhance the human analytical capability with human intelligence amplification (IA).<sup>54</sup> IA represents a capacity to produce a true expert system. Artificial intelligence and intelligence amplification are critical to fully develop the capabilities of JRAPIDS. It will allow JRAPIDS to anticipate and plan the needs of the armed forces in 2025 and provide adaptive planning and execution direction.

### Notes

<sup>1</sup>Richard K. Betts, *Military Readiness: Concepts, Choices, Consequences* (Washington, D.C.: The Brookings Institution, 1995), 41.

<sup>2</sup>*Ibid.*, 47.

<sup>3</sup>General Accounting Office, National Security and International Affairs Division, *Military Readiness: DOD Needs to Develop a More Comprehensive Measurement System* (Washington, D.C.: Government Printing Office, October 1994), 5.

<sup>4</sup>This example of continuous and automatic operational performance reporting is considered to be an “ideal” characteristic of JRAPIDS. Depending on technological advances, this level of reporting may not be available by the year 2025.

<sup>5</sup>General Accounting Office, 5.

<sup>6</sup>Craig S. Moore, J. A. Stockfish, Mathew S. Goldberg, Suzanne Holyrod, and George G. Hildebrandt, *Measuring Military Readiness and Sustainability*, RAND Report R-3842-DAG (Santa Monica, Calif.: RAND, September 1991), 95.

<sup>7</sup>Clark A. Murdock, “Mission-Pull and Long-Range Planning,” *Joint Forces Quarterly* no. 6 (Autumn/Winter 1994): 31.

<sup>8</sup>Lt Gen Jay W. Kelley, USAF, “Brilliant Warrior” (Unpublished paper, Air University, Maxwell Air Force Base, Ala.) February 1996, 1.

<sup>9</sup>Richard Lipkin, “A Face By Any Other Name: How Computers Recognize Faces,” *Science News*, April 2, 1994, 145, and concept found in Maj Leonard Jackson et al., “2025 Logistics: Consider it Done.” (Unpublished 2025 white paper, Air University, Maxwell AFB, Ala., 1996).

<sup>10</sup>2025 Concepts, No. 900523, “Chip in the Head,” 2025 Concepts Database, (Maxwell AFB, Ala.: Air War College/2025, 1996). The concept of placing a microchip in an individual’s brain raises serious ethical issues, but they are outside the scope of this paper.

<sup>11</sup>USAF Scientific Advisory Board, *New World Vistas: Air and Space Power for the 21<sup>st</sup> Century*, summary volume (Washington, D.C.: USAF Scientific Advisory Board, 15 December 1995), 67.

<sup>12</sup>Paul Kaminski, “We Really Don’t Know,” *Financial World* no. 22 (24 October 1995): 56.

<sup>13</sup>“New Growth in Automatic Data Collection,” *Industry Week* no. 16 (19 August 1993): AIM 3.

<sup>14</sup>“Manufacturing: Fertile Soil for ADC,” *Industry Week* no. 16 (19 August 1993): AIM 6.

<sup>15</sup>2025 Concepts, No. 900335 “Worldwide Military Cellular Phone System,” 2025 Concepts Database, (Maxwell AFB, Ala.: Air War College/2025, 1996).

<sup>16</sup>Daniel J. Biby, “Who Really Needs EDI?” *Industry Week* no. 21 (2 November 1992): 45.

<sup>17</sup>*Ibid.*, 32.

<sup>18</sup>James T. Silva, “Please Debrief Me!” *Air Force Journal of Logistics*, Spring 1992, 19–20.

- <sup>19</sup> Lance A. Glasser, "Today's Technology Begets Tomorrow's Military Readiness," Internet address: <http://www.au.af.mil/>, *ARPA Press Release*, 1 February 1995.
- <sup>20</sup> Arthur B. Morrill, "Lean Logistics: Its Time Has Come!" *Air Force Journal of Logistics*, Spring-Summer 1994, 8–15. Another template that could be used is the battlefield responsive agile integrated network (BRAIN), a master logistics processing system espoused in the **2025** white paper by Maj Leonard Jackson et al., "**2025** Logistics: Consider it Done," (Unpublished **2025** white paper, Air University, Maxwell AFB, Ala., 1996).
- <sup>21</sup> Moore et al., 95.
- <sup>22</sup> General Accounting Office, National Security and International Affairs Division, *Military Readiness: DOD Needs to Develop a More Comprehensive Measurement System* (Washington, D.C.: Government Printing Office, October 1994), 5.
- <sup>23</sup> Ibid., 5.
- <sup>24</sup> Maj Jeff Fink, Headquarters USAF/XOOR, telephone interview with Lt Col David M. Snyder, 4 April 1996.
- <sup>25</sup> Fink, interview, and Col James N. Worth, USAF/USACOM, J-32 Readiness Division, telephone interview with Lt Col David M. Snyder, 5 April 1996.
- <sup>26</sup> Col James N. Worth, USAF/USACOM, J-32 Readiness Division, telephone interview with Lt Col David M. Snyder, 5 April 1996.
- <sup>27</sup> JRAMS Briefing, undated, telephone facsimile provided by Col James N. Worth, USAF/USACOM, J-32 Readiness Division, 5 April 1996.
- <sup>28</sup> Worth, interview.
- <sup>29</sup> Ibid.
- <sup>30</sup> Col Richard Szafranski, USAF/AWC, assessor comment on **2025** Team Y JRAPIDS white paper (Maxwell AFB, Ala.: Air War College/**2025**, 25 March 1996).
- <sup>31</sup> **2025** Concepts, No. 900329, "Human Friendly Design," **2025** Concepts Database, (Maxwell AFB, Ala.: Air War College/**2025**, 1996).
- <sup>32</sup> **2025** Concepts, No. 900645, "Right Pilot," **2025** Concepts Database (Maxwell AFB, Ala.: Air War College/**2025**, 1996).
- <sup>33</sup> Moore et al., 66.
- <sup>34</sup> Jeffrey Cooper, SAIC, electronic mail message received by Lt Col David M. Snyder at 1133 hours, 4 April 1996.
- <sup>35</sup> Ibid.
- <sup>36</sup> **2025** Concepts, No. 900516, "Generation X Theater Level Combat Simulation," **2025** Concepts Database (Maxwell AFB, Ala.: Air War College/**2025**, 1996).
- <sup>37</sup> John L. Petersen, *The Road to 2015* (Corte Madera, Calif.: Waite Group Press 1994), 292.
- <sup>38</sup> Kelley, 10.
- <sup>39</sup> **2025** Concepts, No. 900175, "Virtual-reality Trainers;" No. 900516, "Generation X Theater Level Combat Simulation;" No. 200004, "Advanced MILSATCOM Capabilities;" and No. 200007, "Rehearsal For All Missions, in a Mission Media, without Vehicle Movement," **2025** Concepts Database (Maxwell AFB, Ala.: Air War College/**2025**, 1996).
- <sup>40</sup> Nicholas P. Negrofonte, *Being Digital* (New York: Vintage Books, 1995), 117.
- <sup>41</sup> Ken Pimental and Kevin Teixeira, *Virtual-reality: Through the New Looking Glass* (New York: Intel/Windcrest 1995), 341.
- <sup>42</sup> Petersen, 292.
- <sup>43</sup> **2025** Concepts, No. 200007, "Rehearsal in All Missions, in a Mission Media, Without Vehicle," No. 900175, "Virtual-reality Trainers," No. 900516, "Generation X Theater Level Combat Generation Simulation," No. 900534, "Virtual Force **2025**," No. 900629, "VR for Cultural Competence," No. 900643,

“On Platform Initial Flying Training,” and No. 900680, “Holographic Meetings,” *2025 Database* (Maxwell AFB, Ala.: Air War College/2025, 1996).

<sup>44</sup> Capt John D. Cox and Capt Hugh G. Severs, USAF, “*The Relationship Between Realism in Air Force Exercises and Combat Readiness*,” thesis (Wright-Patterson AFB, Ohio: Air Force Institute of Technology, September 1994).

<sup>45</sup> Petersen, 292.

<sup>46</sup> Szafranski.

<sup>47</sup> Edward L. Fix, *Neural Network Based Human Performance Modeling* (Wright-Patterson AFB, Ohio: Harry G. Armstrong Aerospace Medical Research Laboratory, October 1990), 19.

<sup>48</sup> *Ibid.*, 19.

<sup>49</sup> Eric Mankin, “Computers Learn to Match Wits with Humans,” Internet address [http://www.usc.edu/dept/News\\_Service/ns\\_staff/mankin.html](http://www.usc.edu/dept/News_Service/ns_staff/mankin.html), 15 March 1996.

<sup>50</sup> Eric Dietrich, *Thinking Computers and Virtual Persons: Essays on the Intentionality of Machines*, (New York: Academic Press 1994), 6.

<sup>51</sup> Pimental and Teixeira, 341.

<sup>52</sup> Douglas B. Lenat, “Artificial Intelligence: A Crucial Storehouse of Common Sense Knowledge Is Now Taking Shape,” *Scientific American* no. 3 (September 1995), 63.

<sup>53</sup> *Ibid.*

<sup>54</sup> Szafranski.

## Chapter 5

### Investigative Recommendations

Today's readiness reporting system is inadequate for the air and space forces of 2025. The DOD should pursue the development of a JRAPID-type system capable of assessing and predicting force capability needed to meet the demands of all potential future worlds. The possible benefits derived from this system include both enhancements in force readiness and sustainability at substantial cost savings.

We recommend DOD develop JRAPIDS in an integrated, yet incremental, approach. The modular system design lends itself to this type of implementation strategy. Within this construct, each module would be developed as technology becomes available. The following key steps should be taken to ensure the successful system integration.

- Pursue development of the key emerging technologies, identified within this paper, enabling the likelihood of future JRAPIDS integration.
- Adopt a more comprehensive definition of readiness allowing a time-variable and mission-scaleable measure of merit for the enabling portion of overall military capability.
- Support ongoing joint staff initiatives, such as JARS, which will help build performance-based, time-oriented representations of unit readiness.
- Support and fund systems which link existing modeling systems, such as JRAMS and JARS, using an object-oriented architecture.
- Continue the development of comprehensive JMETLs
- Specify and verify performance measurements for all facets of individual, unit, and joint force readiness.<sup>1</sup>
- Begin identification, coordination, and integration of all relevant readiness and sustainment databases, such as individual, unit, and joint force processing; training capacities, condition and availability of personnel, equipment, and supplies needed before and after deployments; and key sustainability resources.<sup>2</sup>

The first steps in the journey to a new readiness system have already begun. The challenges of the next decade include identifying the relevant databases, devising the necessary means to access and transform the

data into objective readiness information, and then distributing the information in real time to all levels of decision makers.

JRAPIDS as we envision it will require substantial, sustained funding. Initial funding for JARS is \$40 million.<sup>3</sup> We estimate the total cost to fully implement JRAPIDS will exceed 10 times this amount over the 30-year development/implementation process. Savings from leveraging system components being put in place during this time period will be significant. However, the most important savings comes from the efficient management of force readiness trade-offs. This will provide the air and space forces of 2025 with the most cost-efficient, mission-effective readiness posture ever.

In conclusion, force management in 2025 requires an integrated system that provides commanders and decision makers with a comprehensive way to assess readiness and sustainment while custom designing operational training to meet performance levels specified by the given mission. JRAPIDS will provide a modular integrated tool to assess individual, unit, and joint force readiness in real time. JRAPIDS will allow commanders at all levels to make trade-off decisions between training, sustainment, and readiness. It is a total force tool for use by all US armed forces.

### Notes

<sup>1</sup> Craig S. Moore, J. A. Stockfish, Mathew S. Goldberg, Suzanne Holyrod, and George G. Hildebrandt, *Measuring Military Readiness and Sustainability*, RAND Report R-3842-DAG ( Santa Monica, Calif.: RAND, September 1991), xiii.

<sup>2</sup> Ibid., xiii.

<sup>3</sup> Col James N. Worth, USAF/USACOM, J-32 Readiness Division, telephone interview with Lt Col David M. Snyder, 5 April 1996.

## Acronyms

ACTD	advanced concept technology demonstration
ADC	automatic data collection
AI	artificial intelligence
AJMRR	Automated Joint Monthly Readiness Review
C-Rating	capability rating
CRAF	civil reserve air fleet
CAS	close air support
C <sup>3</sup>	command, control and communication
C <sup>4</sup> I	command, control, communications, computers, and intelligence
CINC	commander in chief
CFRS	computerized fault reporting system
CONOP	concept of operations
CONPLAN	concept plan
DOC	designed operating capability
DOD	Department Of Defense
EDI	electronic data integration
FEBA	forward edge of the battle area
FW	fighter wing
GCCS	global command and control system
GSORTS	global status of resources and training system
IA	intelligence amplification
JARS	joint automated readiness system
JCS	Joint Chiefs Of Staff
JMET	joint minimum essential task
JMETL	joint minimum essential task listing
JOPES	joint operations planning and execution system
JRAMS	joint readiness automated management system
JRAPIDS	joint readiness assessment and planning integrated decision system
JTF	joint task force
JULLS	joint universal lessons learned system
MRSP	mobility readiness spares package
NCA	national command authorities
OPLAN	operation plan
OPTEMPO	operating tempo
OSD	Office of the Secretary of Defense
PAA	primary aircraft assigned
PERSTEMPO	personnel tempo
PPBS	planning, programming, and budgeting system
QR	quick response
RFID	radio frequency identification
SAB	Scientific Advisory Board
SKE	station keeping equipment
SORTS	status of resources and training system
S-Rating	sustainability rating
TA	tactical
TPFDD	time phased force deployment data
USACOM	United States Atlantic Command
USAF	United States Air Force

USSTRATCOM  
VR

United States Strategic Command  
virtual-reality



## ***Bibliography***

- Air Force Executive Guidance. December 1995, Update.
- Armed Forces Staff College Publication One, *The Joint Staff Officer's Guide, 1993*. Norfolk, Va.: National Defense university Armed Forces Staff College.
- Air University, *Spacecast 2020: The World of 2020 and Alternate Futures.* Maxwell AFB, Ala.: Air University Press, June 1995.
- Betts, Richard K. *Military Readiness: Concepts, Choices, Consequences*. Washington, D.C.: The Brookings Institution, 1994.
- Biby, Daniel J. "Who Really Needs EDI?" *Industry Week*. Vol. 241, No. 21, 2 November 1992.
- Collins, John M. "Military Readiness: Principles Compared with US Practices." *Congressional Research Service*, The Library of Congress, 21 January 1994.
- Cox, Capt John D. and Severs, Capt Hugh G., USAF. "*The Relationship Between Realism in Air Force Exercises and Combat Readiness.*" Thesis. Wright-Patterson AFB, Ohio: Air Force Institute of Technology, September 1994.
- Department of the Army. *Army Focus: Force XXI*. Washington, D.C.: Headquarters Department of the Army, 15 January 1995.
- Department of Navy. *Forward From the Sea*. Washington, D.C.: Headquarters United States Navy, 1995.
- Dietrich, Eric. *Thinking Computers and Virtual Persons: Essays on the Intentionality of Machines*. New York: Academic Press, 1994.
- Fix, Edward L. "Neural Network Based Human Performance Modeling." Wright-Patterson AFB, Ohio: Harry G. Armstrong Aerospace Medical Research Laboratory, 1994.
- Glasser, Lance A. "*Today's Technology Begets Tomorrow's Military Readiness.*" ARPA Press Release, Internet, 1 February 1994.
- Greenberg, Ira. *The Multilevel Secure Real-Time Distributed Operating System Study*. New York: Griffiss AFB, May 1993.
- James, Maj Glenn E. "Chaos Theory: The Essentials for Military Applications," *Air Command and Staff College Theater Air Campaign Coursebook*. Maxwell AFB, Ala., 1995.
- Joint Publication 1-02, *Department of Defense Dictionary of Military and Associated Terms*. 23 March 1994.
- Kaminski, Paul. "Logistics, We Really Don't Know," *Financial World*. Vol. 164, No. 22, 24 October 1995.
- Kennedy, Paul. *Preparing for the Twenty-First Century*. New York: Random House, 1993.
- Laskowski, Lt Cmdr Mathew Ludwig. *Neural Network Decision Support Systems for the Department of Defense: An Exploration*. Monterey, Calif.: Navy Post Graduate School, September 1991.
- Lenat, Douglas B. "Artificial Intelligence: A Crucial Storehouse of Common Sense Knowledge Is Now Taking Shape," *Scientific American*. Vol. 273, No. 3, 3 September 1995.
- Lipkin, Richard. "A Face By Any Other Name: How Computers Recognize Faces," *Science News*. Vol. 145, No. 14, 2 April 1994.

- “Manufacturing: Fertile Soil for ADC,” *Industry Week*. Vol. 242, No. 16, 19 August 1993.
- Mayfield, Lt Col Maurice J., US Army. “*Measurement of Combat Effectiveness During Peacetime Preparations for War.*” Carlisle Barracks, Pa.: US Army War College, 1992.
- Moore, S. Craig; J. A. Stockfish; Mathew S. Goldberg; Suzanne Holyrod; and George G. Hildebrandt. “Measuring Military Readiness and Sustainability.” Santa Monica, Calif.: RAND, 1991.
- Morrill, Arthur B. “Lean Logistics: Its Time Has Come!” *Air Force Journal of Logistics*. Spring–Summer 1994.
- Mowafy, Lyn. *Visualizing Spatial Relationships: Training Fighter Pilots in a Virtual Environment Debrief Interface*. Brooks AFB, Tex. October 1993.
- Murdock, Clark A. “Mission-Pull and Long-Range Planning,” *Joint Forces Quarterly*. No. 6, Autumn/Winter, 1994.
- Nakamoto, Glen. *Multi-Source Integration and Intelligence Analysis*. Griffiss AFB, N.Y.: Rome Laboratory, April 1995.
- “New Growth in Automatic Data Collection,” *Industry Week*. Vol. 242, No. 16, 19 August 1994.
- Petersen, John L. *The Road to 2015*. Corte Madera, Calif.: Waite Group Press, 1994.
- Pimental, Ken and Kevin Teixeira. *Virtual-reality: Through the New Looking Glass.* New York: Intel/Windcrest, 1995.
- Ross, Philip E. “I Can Read Your Face.” *Forbes*. Vol. 154, No. 14, 19 December 1994.
- Silva, James T. “Please Debrief Me!” *Air Force Journal of Logistics*. Spring 1992.
- Turley, Lt Cmdr Leslie S., USN. “The Impact of the Defense Budgeting Process on Operational Readiness.” Monterey, Calif.: Navy Post Graduate School, March 1993.
- United States Advanced Research Projects Agency, *Report of the Senior Working Group on Military Operations Other Than War*. Arlington, Va., May 1994.
- United States Naval Air Warfare Center, “Virtual-reality: An Air Combat T&E Perspective.” Patuxent River, M.D., 1994.
- United States General Accounting Office, National Security and International Affairs Division. “*Military Readiness: DOD Needs to Develop a More Comprehensive Measurement System.*” Washington, D.C., October 1994.
- USAF Scientific Advisory Board. *New World Vistas: Air and Space Power for the 21<sup>st</sup> Century*, Summary Volume. Washington, D.C.: USAF Scientific Advisory Board, 15 December 1995.
- Yates, John D. “IDs Put On a New Face.” *Security Management*. Vol. 37, No. 9, September 1993.

**Virtual Integrated Planning And Execution  
Resource System (VIPERS): The High Ground Of 2025**



A Research Paper  
Presented To

Air Force *2025*

by

Lt Col Gregory J. Miller

Maj Kurt C. Fecht

Maj Barbara Jefts

Maj Laura J. Sampsel

Maj Patrick J. Smith

April 1996

## **Disclaimer**

**2025** is a study designed to comply with a directive from the chief of staff of the Air Force to examine the concepts, capabilities, and technologies the United States will require to remain the dominant air and space force in the future. Presented on 17 June 1996, this report was produced in the Department of Defense school environment of academic freedom and in the interest of advancing concepts related to national defense. The views expressed in this report are those of the authors and do not reflect the official policy or position of the United States Air Force, Department of Defense, or the United States government.

This report contains fictional representations of future situations/scenarios. Any similarities to real people or events, other than those specifically cited, are unintentional and are for purposes of illustration only.

This publication has been reviewed by security and policy review authorities, is unclassified, and is cleared for public release.

## *Contents*

<i>Chapter</i>	<i>Page</i>
Disclaimer.....	ii
Illustrations .....	iv
Tables .....	v
Acknowledgments .....	vi
Executive Summary.....	vii
1 What is Force Support? .....	1
The World of 2025 .....	2
Overview .....	3
2 Required Capabilities .....	5
Requirements.....	5
Capability for Mission Planning and Execution .....	7
Measures of Merit.....	10
3 System Description and Technologies .....	12
National and Theater Strategy .....	13
Knowledge-Based Campaign Planning .....	13
Battle Simulation.....	18
Collaboration and Execution Management .....	19
Information Fusion and Mining .....	20
Enemy Behavior Detection and Prediction .....	20
Technology Progress.....	21
Technology Thresholds.....	23
Promising Technologies .....	24
Microelectromechanical System (MEMS).....	24
Data Storage and Processing.....	25
Real-time Decision Support/Artificial Intelligence (AI) Software.....	28
Image Understanding Software.....	29
Human Machine Interfaces.....	29
Three-Dimensional Holographic Display .....	31

<i>Chapter</i>	<i>Page</i>
4	Concept of Operations..... 38
	Operation Zion..... 38
	Attributes and Measures of Merit..... 42
	System Countermeasures..... 44
	Strategies to Counter Enemy Attack ..... 45
5	Investigation Recommendations..... 50
<i>Appendix</i>	<i>Page</i>
A	Automated Analysis and Summary of Fusion Techniques ..... 52
B	Acronyms..... 54
	Bibliography ..... 55

## **Illustrations**

<i>Figure</i>	<i>Page</i>
2-1.	VIPERS Logic Diagram ..... 9
3-1.	The VIPERS's Process..... 12
3-2.	Sensor Network..... 14
3-3.	Integrated Database System..... 15
3-4.	Example of Layered Databases ..... 16
3-5.	Gray Intelligence Network..... 18
3-6.	Illustration of Projection System..... 19
3-7.	Technological Progress in C4I Systems ..... 22
3-8.	Comparison of Data Storage Capacity and Size..... 26
3-9.	Advances in Areal Density..... 26
3-10.	Example of Holographic Memory Array ..... 27
4-1.	Integrated Sensor Architecture ..... 46

## Tables

<i>Table</i>		<i>Page</i>
1	Potential Databases .....	17
2	Growth in Capabilities of Information Technology .....	22

## *Acknowledgments*

The authors of this paper would like to acknowledge and thank the following individuals who contributed to our understanding of the subject and technologies involved: Kaigham J. Gabriel, Advanced Research Projects Agency, and Mark Lucente, IBM Watson Labs.

A special thank you is in order to Col Thomas Mahr, Dr Irene Pearson-Morrow, and Lt Col Tom Mahoney who patiently guided and encouraged us. Through the numerous iterations of this paper, they cheerfully edited out our errors and suggested many necessary improvements. Thank You!



## *Executive Summary*

Effective command and control systems magnify the unique characteristics of air and space power: flexibility, speed, range, responsiveness, precision, and observation.<sup>1</sup> By 2025, plans, decisions, and actions will occur rapidly and with insight into a potential adversary's movements. Our ability to observe, analyze, and predict will reveal an enemy's weakness and possible intent. By extending the conceptual horizon of the war fighter, we will foster a paralyzing tempo and inhibit the enemy's ability to react or recover. This paper takes a high-ground approach concerning combat support in the future. It describes combat support in terms of people, processes, and products and posits a more descriptive name for combat support in 2025—force support.

This paper educes three core competencies for force support: information supremacy, reflexive sustainment, and precision employment. Other 2025 writing teams address the last two elements. As a means of satisfying the core competency of information supremacy, this paper proposes the virtual integrated planning and execution resource system (VIPERS). VIPERS provides commanders at the strategic, operational, and tactical levels an integrated “system of systems” that achieves information supremacy, allowing dominance of the battlespace.

VIPERS provides commanders the ability to plan collaboratively with combat and support forces. Parallel planning permits simulation of alternate courses of action using war gaming and advanced decision support systems to evaluate congruence of objectives, potential risks, and vulnerabilities. This capability improves upon and hardens the users'

observe-orient-decide-act (OODA) loop,<sup>2</sup> reducing “fog and friction” in executing operations.

VIPERS provides commanders a real-time bird's-eye view of the battlespace during execution. This perspective results in visibility of all logistics from factory to foxhole and improved combat identification. The information is displayed using a three-dimensional holographic projection with natural human-machine interface during planning and execution. VIPERS tailors information from the strategic to the tactical level. This paper describes operational criteria for command and control, the system and its required technologies, and a concept of operations and makes recommendations for further investigation.

### **Notes**

1. AFDD-1, *Air Force Doctrine*, unpublished draft, 1996, 2.
2. John Boyd, “A Discourse on Winning and Losing,” Unpublished briefings and essays, Air University Library, Maxwell AFB, Ala., Document M-U30352-16, no. 7791, August 1987.

## **Chapter 1**

### **What is Force Support?**

Force Support is that part of the military operation that provides operational leverage to the commander. As the shaft of the fighting arrow, force support provides stability and direction. The arrow metaphor illustrates how the precise movement of the arrowhead can become weighted and misguided by a tail that is too long or too unwieldy. If constructed incorrectly, the arrow is ineffective—its impact negated. Force Support (the shaft) transforms the energy of the bow (the national command authorities (NCA) or commander) into decisive operational power.

Future war fighters will find themselves involved in the full spectrum of military operations, ranging from offensive combat operations to peace enforcement and humanitarian assistance. Force Support allows military forces to skillfully perform the actions required to respond rapidly to any situation. While it does not guarantee effective use of military power, without it our armed forces are incapable of exerting a positive influence on achieving the desired end state. When force support fails to enhance the efforts of the combat arms, it becomes crippling to the operation.

## The World of 2025

In order to identify the requirements of force support in 2025, we must first outline the contextual and operational elements. Futurists anticipate the year 2025's having the following attributes:<sup>1</sup>

1. A virtual neighborhood exists, due to global interconnectivity. As a result of the virtual neighborhood, social interaction will take on new forms. The quality of the new forms is still unknown.
2. Computer-aided design and manufacturing have made production nearly paperless and highly automated.
3. Almost every technical discipline wants to view its area of interest in three dimensions. For example, city managers want to see the subterranean view of the water and sewer system in relation to surface structures.
4. Competition for resources has become fierce due to dwindling supplies and burgeoning population. Developed nations and international organizations are constantly pressured with cries for all forms of assistance. Regional conflicts of low intensity are prevalent.
5. The economical and technical gap continues to widen between northern and southern hemispheres.
6. Nongovernmental organizations and transnational entities increase in number and power, exerting significant local, regional, and world-wide political influence.
7. United States citizens' intolerance toward casualties in conflict hardens, and technology advances increase expectations of rapid victory.
8. Though the United States remains strong, there are challenges to its political and military leadership position in the world.

Similarly, this paper asserts air forces will have the following force qualities:

1. Air forces continue to operate weapon systems procured in the twentieth century.
2. Humans remain the primary systems operators.
3. Forward operating locations are required for lodgment, presence, and tempo. US forces and influence are welcome nearly world-wide, but not on a permanent basis.
4. Forces are vulnerable to threats from a variety of approaches (land, air, and sea).
5. Deployed forces need resupply.
6. Despite technological advances in information sharing, as well as the attendant organizational and sociological changes, combatants still require a command and control system.
7. Joint and coalition warfare are the operating norm.<sup>2</sup>

Air forces in 2025 will operate a mix of inhabited and uninhabited combat air vehicles. The purpose of the mix is to field a capability-based force which effectively exploits new technologies. Technology will drive the convergence of commercial and military capabilities and requirements. Aircraft and uninhabited aerial and ground vehicles will project lethal and nonlethal weapons. Large mobility aircraft will provide pinpoint employment of resources via high-altitude, precision airdrop as well as retaining the capacity for more conventional emplacement of resources. Technology advances will generate modifications in many older weapon systems.<sup>3</sup> The latest update of the global positioning system will provide the worldwide architecture for precision operations. Aerospace control will cover the spectrum from space to information. The interconnected force will create a distributed system of databases and will have extensive commercial involvement in all systems.

## **Overview**

This paper focuses on improving airpower's core competency of information supremacy. The study first examines information supremacy's operational requirements and key capabilities needed. This discussion provides a set of criteria to evaluate potential systems against. Next, the paper describes a system that potentially meets these criteria, including advanced technologies and some considerations in applying these technologies. A concept of operations then explains the use of this system. There follows an analysis of enemy countermeasures and strategies to overcome these countermeasures. Finally, the paper recommends what the Air Force should and should not do to attain information supremacy in the twenty-first century.

## Notes

1. John L. Petersen, *The Road to 2015, Profiles of the Future* (Corte Madera, Calif.: Waite Group Press, 1994), 284–85; also see, Lt Col Robert L. Bivins et al., “Alternate Futures” (Unpublished white paper, Air Force 2025, Air University, Maxwell Air Force Base, Ala.) undated.

2. The concepts in this paragraph were extracted from USAF Scientific Advisory Board, *New World Vistas: Air and Space Power for the 21<sup>st</sup> Century*, summary volume (Washington, D.C.: USAF Scientific Advisory Board, 15 December 1995), iv.

3. Lt Col James A. Fellows et al., “Airlift 2025: The First with the Most” (Unpublished white paper, Air Force 2025, Air University, Maxwell Air Force Base, Ala.) undated.

## **Chapter 2**

### **Required Capabilities**

Chapter 1 portrayed the world of 2025 as one filled with regional low-intensity conflicts. The lack of standing operational plans will characterize future crises as each will have unique political, economic, and social parameters. This characterization arises from the fact that bilateral economic and security interests are so prolific that standing plans are illogical—there are too many options. Military forces will mirror corporate virtual structures in that organizations are built for a specific purpose or product and disbanded when that goal is met. This chapter identifies the requirements of force support in 2025 and then discusses the capabilities necessary.

### **Requirements**

The most important requirement of force support in 2025 is synchronized support to combatants. Force Support must sustain combatants with significantly less lift into the remotest areas of the world. Future combat forces will disperse on the battlefield because of improvements in information connectivity—demassified forces.<sup>1</sup> Force Support must also disperse for nonlinear, simultaneous operations to become a reality. The traditional response to increasing demands by combat forces has been “more, bigger, and faster.” In

2025 the armed forces will respond with collaborative-parallel planning as opposed to today's largely stovepipe-sequential process.

The US armed forces have many years of experience with command and control systems of increasing complexity. This experience has revealed some key lessons learned from situations which continually recur—despite technology advancements. Coordinated execution with decentralized operations is possible with:

1. Simple rules,
2. Empowerment using mission type orders, and
3. Ability to adapt to local conditions.<sup>2</sup>

Commanders need control of operational processes, not resources.<sup>3</sup> This requirement means commanders cannot afford to get lost in details, but must focus on what is happening in relationship to the desired end state. Information and intelligence systems should place commanders in a position of control, not dependency.<sup>4</sup> Technology provides the capability for leaders to micromanage resources. Further, technology raises serious questions about the span of control in the conduct of military operations. Civilian and military leaders need to avoid these pitfalls through training, leadership, and doctrine.

In combat, commanders don't require 100 percent solutions; they want pointed answers usually derived from relational databases, not information databases.<sup>5</sup> Concurrently, "real-time" information is less important than "in-time" information.<sup>6</sup> Capabilities should be designed so all processes are mainstreamed and everyone uses the same systems.<sup>7</sup> Hardware restrictions should not prevent anyone from having access to information.<sup>8</sup>

Redistributing mass within the battlespace and movement suggests that our forces are agile. Simple rule sets, empowerment, and adaptation to local conditions suggest large-



scale synchronization and awareness of objectives and end states. The succeeding section explains the methods and tools by which decision makers can achieve this level of coordination, integration, and insightful movement toward objectives.

### **Capability for Mission Planning and Execution**

Conflicts will often occur at great distance, with minimal response time, possibly into areas with undeveloped infrastructures.<sup>9</sup> To respond to these challenges adequately, commanders must see the battlespace rapidly, plan with assurance, issue operational orders, and close with the proper supplies and equipment where desired.

Operational and support planning in 2025 will occur collaboratively and in parallel.<sup>10</sup> Commanders and their staffs will evaluate courses of action using real-time wargaming with intelligent feedback regarding adequacy, feasibility, acceptability, and consistency with doctrine.<sup>11</sup> The commander with VIPERS will have superior battlespace awareness and will quickly grasp the essential contextual and operational elements of a crisis. The system will be fully downlinked throughout the organization. Tailored programming will provide subordinate commanders access to the system for accomplishing all aspects of the mission. Component miniaturization will allow these people to trade their status boards, maps, and overlays for individualized, real-time products.

VIPERS will use a variety of technologies to achieve this capability. Combining multispectral sensing with real-time data fusion<sup>12</sup> and intelligent, decision-support systems will be essential for planning and execution in 2025.<sup>13</sup> Advanced display technologies will optimize human understanding by eliminating unnecessary detail.<sup>14</sup> Evolutionary

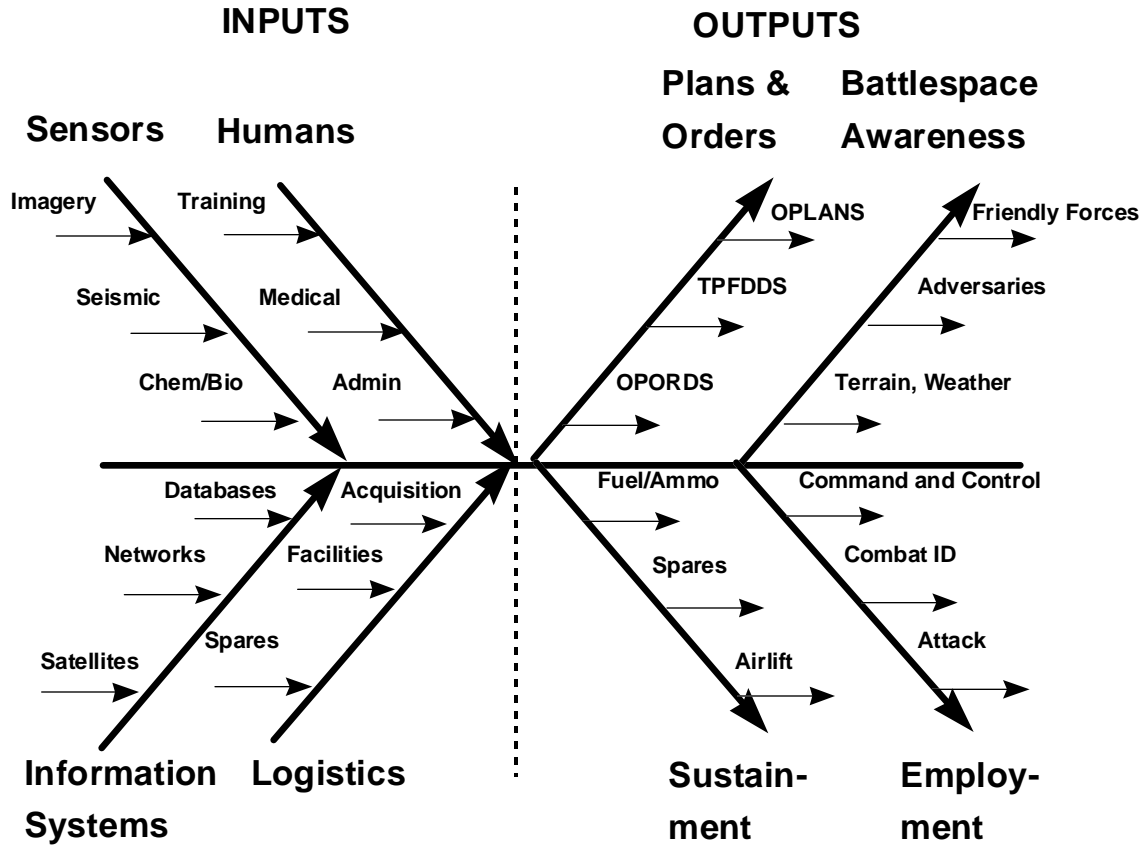
technology developments married with revolutionary changes in command and control will provide air and space forces an enhanced core competency—information supremacy.

The need for an improved human-machine interface stresses the importance of interactive holographic display as an essential system capability.<sup>15</sup>

Humans discover and understand their world through visual sensations. The first step to machine accommodation of the human user is the creation of an intuitive, yet richly interactive, visual interface that allows the user to see and manipulate all types of natural and synthetic imagery.<sup>16</sup>

Interactive holography allows this process to occur and is the only imaging technique that provides all depth cues.<sup>17</sup> When dealing with air power's three-dimensional capability, it is even more critical to plan and test in a similar medium. Leaders must be able to think three-dimensionally in the twenty-first century in order to fully exploit military forces' accomplishment of objectives. One cannot adequately describe an air or space mission in words or in a two-dimensional pictorial display.

VIPERS's integration of databases provides the commander a nexus for interactive operational planning, execution, and evaluation. Figure 2-1 shows the merging of information sources which provide input to VIPERS and specifies desired outputs from the system. As depicted, data from information systems combined with information about logistics and personnel will provide commanders with battlespace awareness, enabling them to effectively plan to employ and support their forces.



**Figure 2-1. VIPERS Logic Diagram**

The network of sensors and information systems generates the fused multidiscipline intelligence information.<sup>18</sup> The continuous input of operational data and concurrent analysis permits instantaneous response to changing conditions.

As computers are integrated more and more into the decision making-process, it is paramount that humans retain the ability to make critical judgments concerning life and death. “We . . . must never lose sight of our moral obligation to consider the human element first, and foremost, in the life-threatening arena of the battlefield. . . .Let us never forget that computers do not bleed, men and women do.”<sup>19</sup>

## Measures of Merit

In 2025 command and control systems will be judged effective in relation to their ability to

1. Survive direct and indirect attack.
2. Plan effective operations efficiently.
3. Enhance decision making.
4. Provide greatly improved connectivity, with vastly improved reliability, security, and capacity employing improved human interfaces superior to those available in 1996.
5. Integrate the battlespace view quickly with a high degree of correlation between the projected image and ground truth.
6. Finally, provide effective and efficient control of resources.

The system presented, VIPERS, will significantly improve upon each of these attributes using technologies, historical lessons, and conceptual models achievable in the next 20 to 30 years. Next, Chapter three presents a system description encompassing leading-edge technologies to show how VIPERS satisfies these criteria.

## Notes

1. "Forward. . .From The Sea," Online. Available protocol: <http://www.ncts.navy.mil/navpalib/policy/fromsea/fprward.txt>, "Longpoles in the Sea Dragon Tent," Online. Available protocol: <http://138.156.204.100/ww/cwl/cwllpls.htm>, 9 April 1996.

2. 2025 advisor's meeting, Air University, Maxwell Air Force Base, Ala., 24–26 March 1996.

3. Ibid.
4. Ibid.
5. Ibid.
6. Ibid.
7. Ibid.
8. Ibid.

## Notes

9. *Rome Laboratory FY95 Command Control Communications and Intelligence C<sup>3</sup>I Technology Area Plan* (Headquarters Air Force Materiel Command, Wright-Patterson Air Force Base, Ohio, June 1994).

10. USAF Scientific Advisory Board, *New World Vistas: Air and Space Power for the 21<sup>st</sup> Century*, executive summary (Washington, D.C.: USAF Scientific Advisory Board, January 1996).

11. Joint Publication 5-0, (Washington, D.C.; United States Government Printing Office, 13 April 1995), I-13.

12. The concept of data fusion includes a number of combining, analyzing, and layering processes which are performed prior to user access. Databases are screened for relevance and imagery. Other visual media are combined, and an intelligent agent determines relative importance. From these, products are created to optimize human perception and support decision making requirements. Further information on intelligent agents can be found in Bill Gates, Nathan Myhrvold, and Peter Rinearson, *The Road Ahead* (New York: Viking Press, 1995), 31–34, and in multiple sources by Pattie Maes of the MIT Media Lab. Optimizing human perception of complex imagery has been studied in the Spatial Imaging section of MIT Media Lab (and other labs as well) as part of DOD-supported projects under Senior Investigator Nicholas Negroponte.

13. **2025** Concept, No. 200059, “Automated and Integrated Intelligence Seamless Fusion and Correlation System,” **2025** Concept database (Maxwell AFB, Ala.: Air War College/**2025**, 1996).

14. Dr Mark Lucente, MIT Media Labs, on-line, Internet, 4 March 1996, available from <http://lucente.www.media.mit.edu.people/lucente.pubs>. **2025** Concepts, No. 900792, “Holographic Charged Couple Display,” No. 200119, “Data Fusion,” No. 900161, “Holographic C<sup>2</sup> Sandbox,” No. 900385, “3-D Holographic Display,” No. 900417, “Battlespace Awareness Holosphere,” and No. 900667, “Real-Time War Status Board,” **2025** Concept database (Maxwell AFB, Ala.: Air War College/**2025**, 1996).

15. **2025** Concept, No. 900182, “Neuro-network Computer Interface” and No. 200191, “Neural Interfaces,” **2025** Concept database (Maxwell AFB, Ala.: Air War College/**2025**, 1996).

16. Dr Mark Lucente, “Imaging Sciences and Technology,” IBM Research: Visualization Spaces: Imaging Sciences and Technology, online, Internet, 4 March 1996, available from <http://www.research.ibm.com/imaging>.

17. Dr Mark Lucente, MIT Media Labs, on-line, Internet, 4 March 1996, available from <http://lucente.www.media.mit.edu.people/lucente.pubs>.

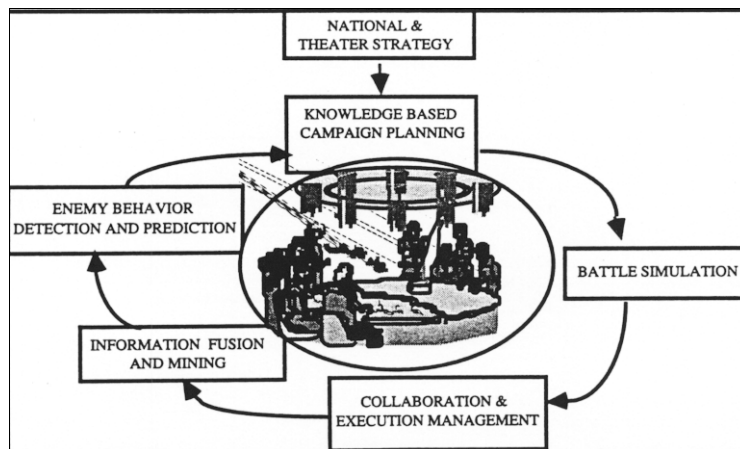
18. Multidiscipline information is the processed data collected from the full gamut of intell communities which, when married, create a usable product.

19. CWO William E. Fleming, USMC, VGMR, MAG 36, telephone interview with co-author Maj Laura J. Sampsel, 11 April 1996.

## Chapter 3

### System Description and Technologies

The Virtual Integrated Planning and Execution Resource System--VIPERS--enables commanders and their staffs, in conjunction with supporting commands, to collaboratively plan and execute using the process depicted in figure 3-1. Using this process, we can describe the system's elements as they relate to the whole.



**Source:** USAF Scientific Advisory Board, *New World Vistas: Air and Space Power for the 21<sup>st</sup> Century* (unpublished draft, the information applications volume, 15 December 1995), 58.

**Figure 3-1. The VIPERS's Process**

## **National and Theater Strategy**

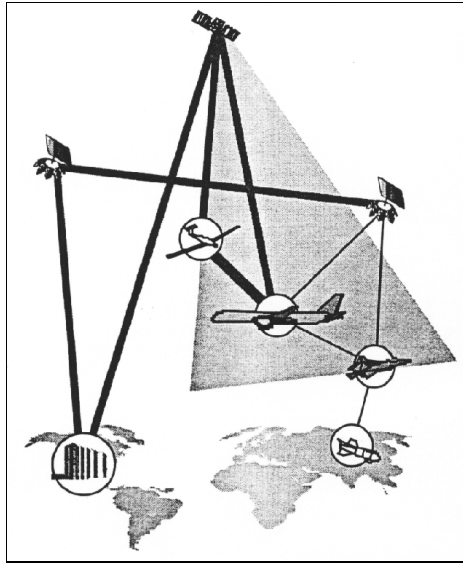
As crises develop, VIPERS provides visibility of ongoing events to the NCA, political leaders (elected and appointed), and theater commanders. VIPERS facilitates instant teleconferencing between decision makers, providing real-time imagery to help them assess critical situations and develop a national response using the various instruments of power. Large databases coupled with high bandwidth communication permit simultaneous access of archived information regarding history and related events. Desired end states, the purview of political and military leadership, serve as the basis for operational planning. Once the desired end state is determined, the theater commanders can provide guidance and intent for further plan development.

## **Knowledge-Based Campaign Planning**

VIPERS enables commanders to perform knowledge-based campaign planning by using fused multispectral imagery combined with spatial data, all-source intelligence, and archived information. Knowledge-based planning enhances accuracy and improves the awareness of operational and support planners. Accuracy is enhanced because detailed data on force and equipment status is accessible in a tailored format. Awareness is improved because space and time relationships between the environment and forces are graphically depicted. Inherent in this kind of intelligent campaign planning is the extensive testing and analysis of possible courses of action through wargaming.

VIPERS integrates near-real-time, fused information regarding personnel strength, force availability, strategic transportation assets, training, and logistics via automatic up

chain-of-command reporting. Information fusion is accomplished through a linked sensor network, as shown in figure 3-2.



**Source:** New World Vistas, (unpublished draft, the information applications volume), x.

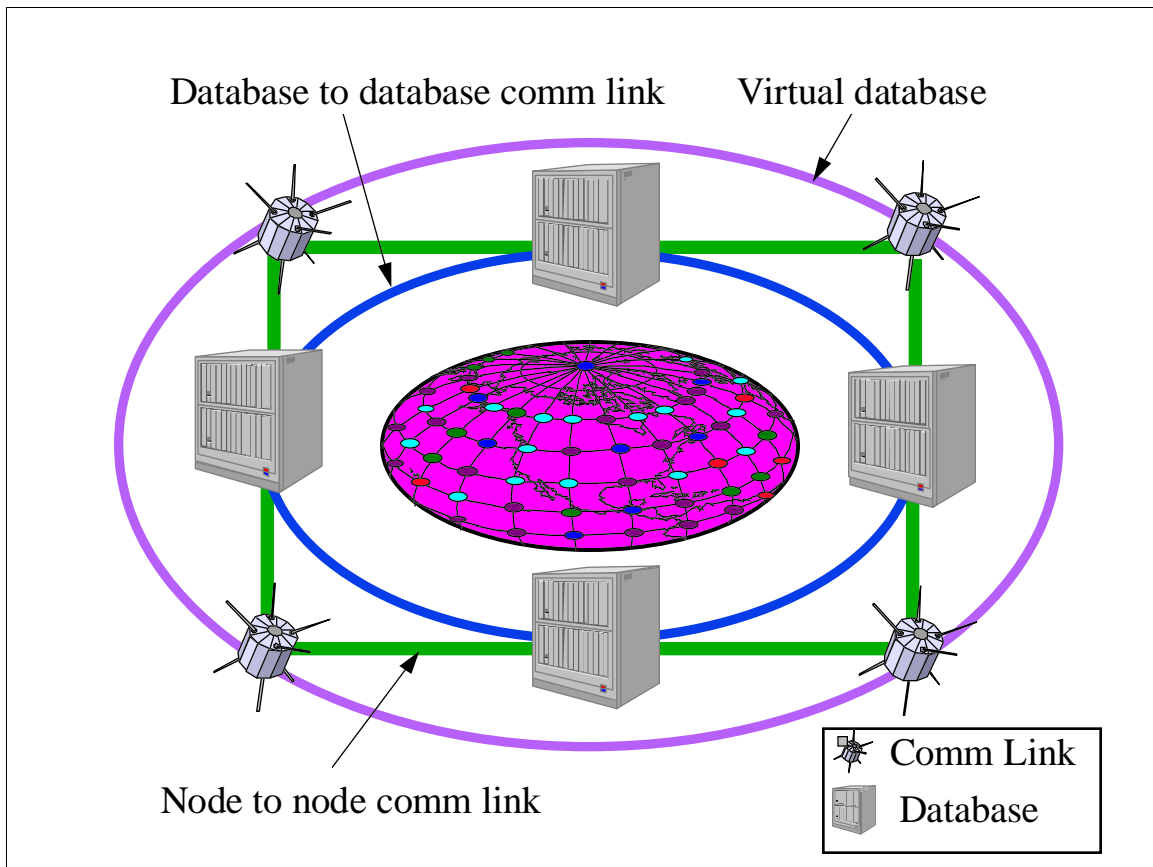
**Figure 3-2. Sensor Network**

The network's nodes consist of space-based, air-breathing (inhabited and uninhabited) surface and subsurface sensors. Communications will rely upon various media using continuous and burst transmissions to provide a low probability of interception, detection, and tampering. Fiber, wire, and packet communication systems will help achieve the necessary connectivity.

Integrated relational databases are key to VIPERS, because they permit the worldwide distribution of knowledge-based information essential to all realistic planning and operations. To use a present-day example, the joint tactical integrated data system (JTIDS) functions as a virtual database by allowing the warrior to extract information from the bit stream at any time. Similarly, the integrated databases in 2025, as depicted in

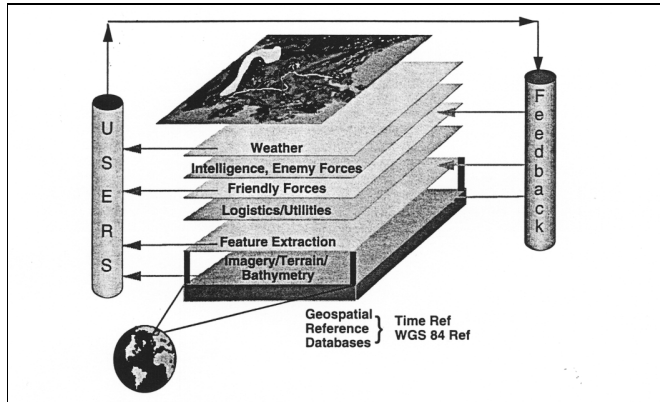


figure 3-3, will allow worldwide access to all-source intelligence, given the proper access and authorization controls.



**Figure 3-3. Integrated Database System**

Layering of databases is a required step toward intelligent fusion. This layering reduces the amount of information the human must process, enabling faster and more complete understanding. Figure 3-4 shows VIPERS's concept for layering databases.



Source: *New World Vistas*, (unpublished draft, the information applications volume), 57.

**Figure 3-4. Example of Layered Databases**

The system overlays each database onto a georeference grid with location and time indexing. Data translates into relevant information via fusion once organized into a logical framework. Fusion combines useful data from the various sources and suppresses information that is unusable. The benefit of layering and fusion is that the “synthesized picture of the battlefield that emerges is better than any view that can be obtained from raw data.”<sup>1</sup> Keys to functionality are the techniques and supporting software that allow the system to review, analyze, distribute, and archive information. Table 1 depicts a reasonable cross-section of the types of data the VIPERS will access and fuse.

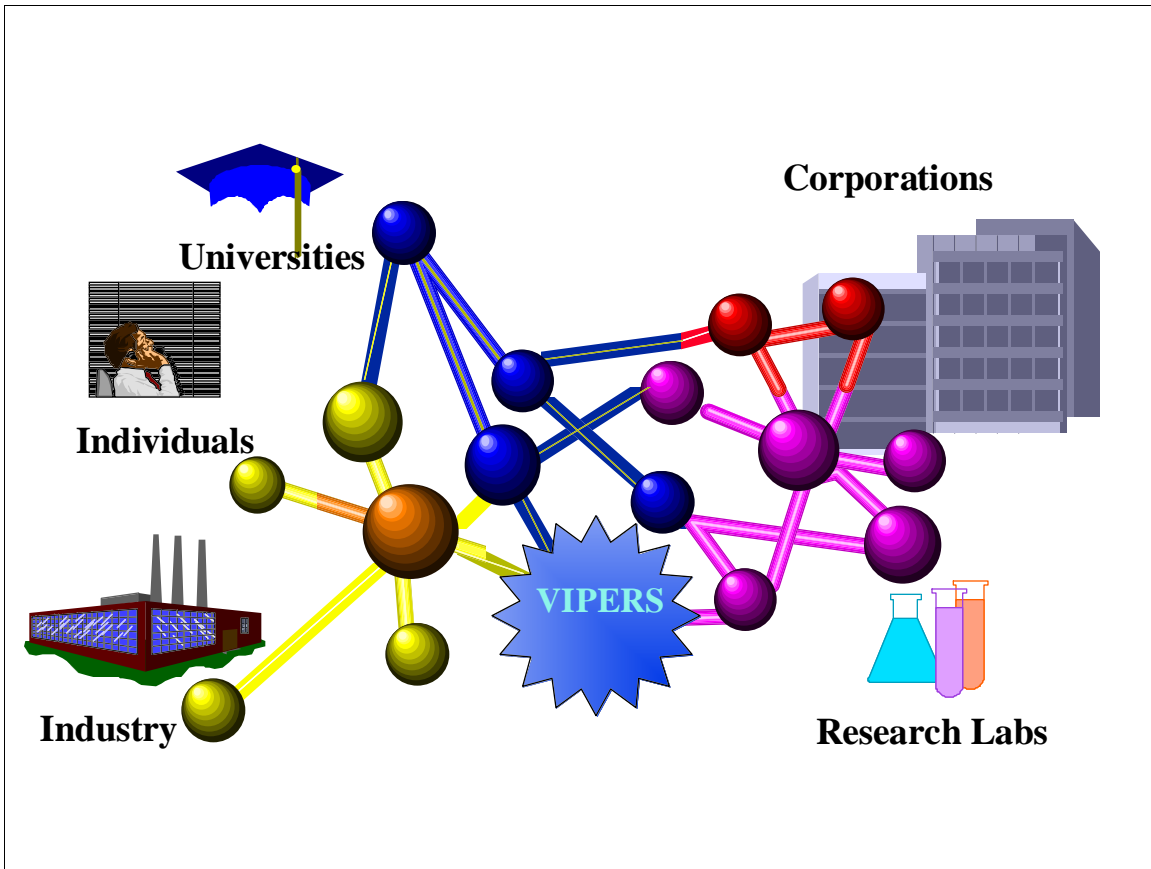
**Table 1**

**Potential Databases**

<b>United States Government</b>	<b>Intelligence Databases</b>	<b>Geographic Information Systems</b>	<b>Public Information and Gray Intelligence</b>
JOPEs	Multispectral Imagery	LANDSAT	Library of Congress
LOGSTAT	HUMINT, SIGINT, MASINT, ELINT	NOAA (weather data/DMSP)	Worldwide Web
SORTS	DIA/CIA and other intel sources analysis	Demographics (Population, Age, Growth Distributions)	University Academics
PPBS	INTERPOL, FBI, Police Databases	DMA/Topographic and Geodetic	Private Corporations
PC-III/ Personnel Readiness	Indications and warning	Political, Cultural, Ideologic, Economic, Geography	Medical (WHO/CDC)
Medical		Morphology	Environment

See appendix B for acronym definitions

Although intelligence is never perfect, use of “gray intelligence” with classical intelligence expands the possible realm of insights into adversaries' cultures, intentions, motivations, and infrastructures. Figure 3-5 illustrates a sample of gray intelligence sources.



**Source:** Adapted from undated briefing on Air Force C<sup>4</sup>I Visioneering and Long-Range Planning, HQ Air Force Communication Planning Directorate.

**Figure 3-5. Gray Intelligence Network**

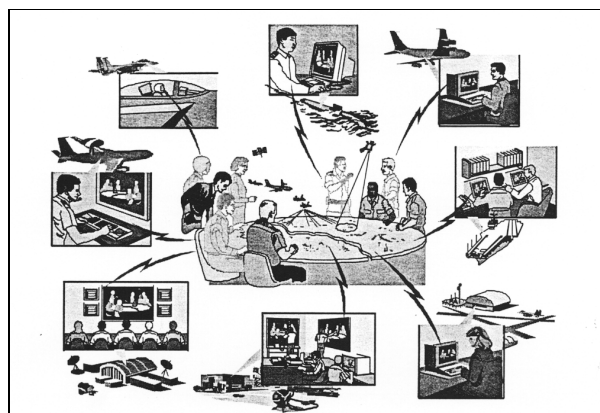
### **Battle Simulation**

By combining natural human interfaces with intelligent decision support systems (DSS), commanders will be able to war-game ongoing situations.<sup>2</sup> This ability permits risk and vulnerability analysis to refine force, logistic, and transportation planning. DSS are organic to VIPERS. Automatic alerting ensures that assumptions or desired activities are supportable in light of available personnel, equipment, and timing. Intelligent DSS will also offer corrective alternatives for deficiencies. Commanders retain the right of accepting computed risk or disagreeing with recommended actions; however, conditions

that cause failure will not allow further progress in the plan until they are corrected. For example, a commander intends to employ a unit in a critical operation before forces are in-theater. VIPERS alerts and offers alternate forces for employment or suggests modified timing of the course of action. Intelligent software generates next-generation operational orders to turn selected courses of action into reality.

### **Collaboration and Execution Management**

The capabilities of VIPERS extend to all levels of warfare (strategic, operational, and tactical) across the spectrum of conflict to execute operations. Commanders will direct, coordinate, and reconstitute their forces while seeing the battlespace in real-time. This system will further serve the commander by allowing him to “process control” via alert functions and command by negation. The primary human-machine interface is voice.<sup>3</sup> Conversational language, properly interpreted for context and inflection, is the principal mode of operating VIPERS. As shown in Figure 3-6, the battlespace will be projected as a three-dimensional holographic image.



**Source:** Mona Toms and Gilbert Kuperman, “Sensor Fusion: A Human Factors Perspective,” research report (Wright-Patterson AFB, Ohio: Armstrong Laboratories, Air Force Systems Command, 1991), 48.

**Figure 3-6. Illustration of Projection System**

Domes best accomplish projection for full visual understanding of air operations. Commanders will use table-top projections where domed projection suites are not available. VIPERS's flexibility, due to large memory capacity, permits individual tailoring of the projected image.<sup>4</sup> Specialized glasses or hand-held projectors can be used for image viewing in remote locations.<sup>5</sup> Field use of VIPERS requires nonverbal system control as well as projections visible only to the user. Small units and individuals have adaptive access to the system's many capabilities, as authorized.

### **Information Fusion and Mining**

The sheer volume of data flowing in from the multitude of distributed sensors and collectors will require intelligent software to rapidly process data into knowledge-based information. An intelligent assistant best achieves this capability. The agent knows what its goal is, strives to achieve it, learns from experience, and responds to unforeseen situations with a repertoire of methods.<sup>6</sup> "It should be autonomous, so that it can sense the current state of its environment and act independently to make progress toward its goal."<sup>7</sup> The agent acts as a guardian to prevent leaders from trapping themselves into mirror imaging or habitual tendencies.

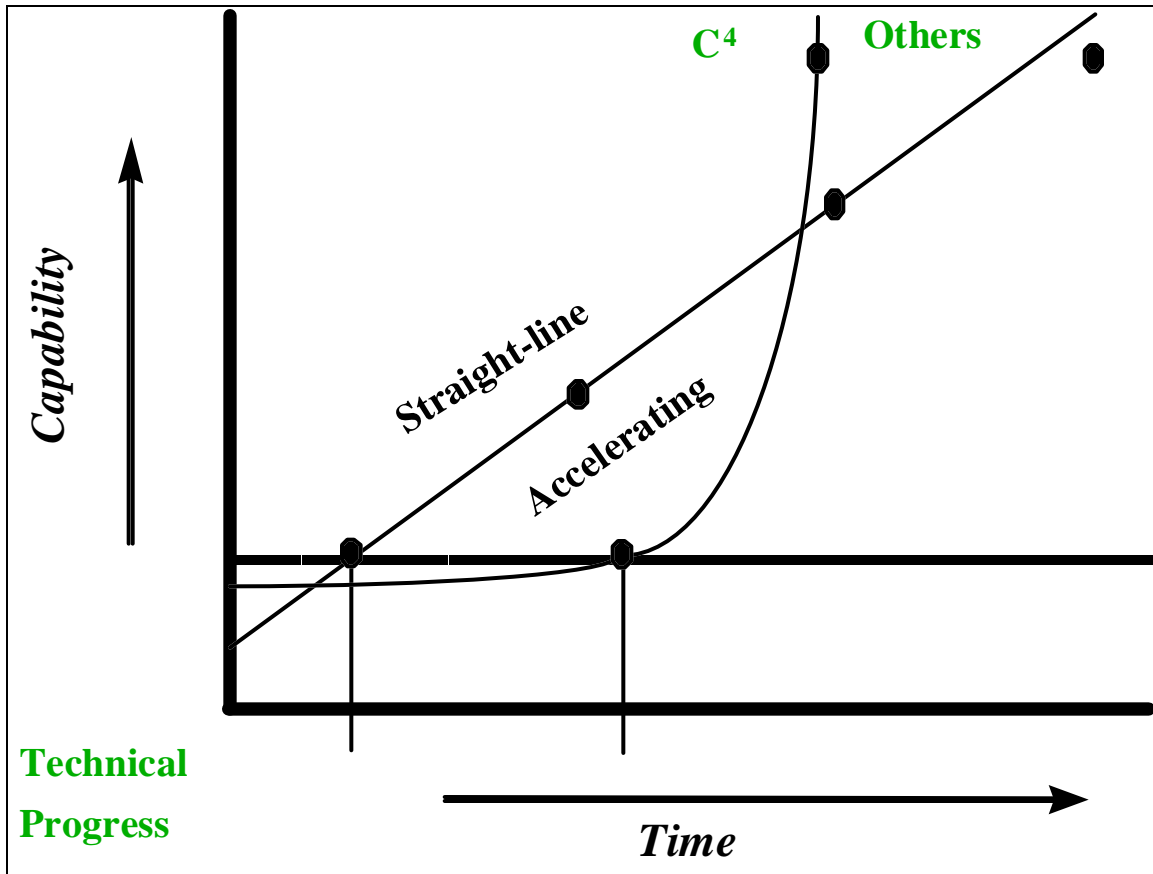
### **Enemy Behavior Detection and Prediction**

Surveillance systems provide the necessary capacity for enemy detection. Prediction flows from real-time observation and capability analysis coupled with historic behavior. The system continually "pushes" every action and reaction to the commander as it updates archival data. The ability to map the earth to one meter will allow modeling of

enemy actions, to a degree only dreamed of before.<sup>8</sup> For example, before starting an air campaign, an entire nation's terrain, infrastructure, and fielded forces can be mapped as links and nodes. This mapping reveals vital connections between systems. As combat assessment and field reports are generated, planners and operators can analyze the effects of targeting. Today's 32 layers of information in metropolitan geographic information systems (large relational databases) will be replaced by 100 layers of data which can accurately predict how damaging a specific node will have cascading effects throughout various political, economic, social, and military systems.

### **Technology Progress**

Studying the pace of technology development is helpful in understanding what VIPERS may achieve in 30 years. Figure 3-7 portrays the differences in advancement of electronic systems compared with other technological endeavors.



Source: Air Force C<sup>4</sup>I Visioneering and Long-Range Planning Briefing, HQ Air Force Communications Planning Directorate, undated.

**Figure 3-7. Technological Progress in C4I Systems**

The accelerating curve is indicative of advances in the microelectronics industry from memory capacity to processing speed. The transistor was invented in the late 1950s but did not achieve substantial growth until the mid-1970s. This nonlinear growth also applies to lasers and other advanced technologies. Similarly, today's new technologies will show little advancement in the next 10 to 20 years (points 1 and 2), but will experience explosive growth in the third decade (point 3). The following table depicts technological progress of today compared to projections for 2010 and beyond.



**Table 2**

**Growth in Capabilities of Information Technology**

Capability	1990	2000	2010
Software	10 MB/User	100MB/User	10 GB/User
Computer Speed	1–25 MIPS	25–100 MIPS	100–1000 MIPS
Software	Serial	Serial & Parallel	Massively Parallel
Network Bandwidth	1–150 Mbps	.1–10 Gbps	10 Tbps
Data Volume	100 Megabytes	1 Terabyte	1000 Terabytes
Response Time	Hours	Minutes	Seconds
Reports	10,000/Day	1,000,000/Day	1,000,000,000/Day
Geopositioning	5 Points/Hour	50 Points/Hour	500 Points/Hour

**Legend:** MIPS- millions of instructions per second, Mbps-megabytes per second, Gbps-gigabytes per second, Tbps-terabytes per second

Engineers refer to the fact that processing and memory capacity double every 18 months as Moore’s Law.<sup>9</sup> Moore’s Law predicts this exponential growth will continue for at least the next 20 years. This pace of development is necessary to create VIPERS, and there are specific thresholds technology must achieve before the system becomes feasible outside a laboratory setting.

**Technology Thresholds**

For VIPERS to become reality, certain technologies must attain a minimum level of performance. For instance, holographic projection needs data storage capacity of no less than 1,000 terabytes.<sup>10</sup> Today, to produce a smooth VHS-quality projection, data transfer rates must be at least 1.2 million bits per second.<sup>11</sup> In 2025, seamless three-dimensional projections will require data access speeds of no less than a million bits per millisecond. The data transfer rate to produce a two-dimensional broadcast-quality image is 30 million bytes per second<sup>12</sup> which requires greatly increased bandwidth. Lucente asserts, “There

are no technical limits to bandwidth. Bandwidth is limited only by cost."<sup>13</sup> This opinion is largely supported by history. In 1961 computer memory cost \$8 per byte. Three megabytes of computer memory cost \$60 or 0.00002 dollars per byte in 1995; therefore, the computer memory cost for complex graphics in 2025 is insignificant.<sup>14</sup> These historical trends indicate that the following technologies, vital to VIPERS's operation, are not only possible but feasible given fiscal adequacy.

### **Promising Technologies**

VIPERS results from combining several advanced technologies. Flexible, "anytime-anywhere" battlespace management requires an array of sensors to provide continuous coverage of areas of interest.<sup>15</sup> Use of miniaturized sensors provides the capability for monitoring the physical environment and enemy operations.

#### **Microelectromechanical System (MEMS)**

Microelectromechanical system (MEMS) technologies are developing rapidly to provide a relatively low-cost, robust sensor for various purposes. These technologies allow creation of active sensors to monitor seismic, chemical, and environmental signatures.<sup>16</sup> Dr Kaighm Gabriel predicts MEMS technologies will reach full maturity within the next 50 years.<sup>17</sup> Rapid exploitation of MEMS in the commercial sector allows the military to capitalize upon these advances. The Advanced Research Projects Agency (ARPA) is playing a strong role in MEMS and should continue to develop its already strong ties with the private sector by funding those areas of research which will most benefit the military.

## Data Storage and Processing

Real-time information fusion is impossible without several orders of magnitude improvement in data storage capacity and processing speed. Exponential increases in both these domains of computing power continue in the commercial sector. Rome Laboratory's C<sup>3</sup>I Technology Area Plan articulates the issues of storage and speed as a thread in virtually all of its thrusts.<sup>18</sup> Reliable holographic storage media using a stacking system and photoreactive polymers are creating one gigabyte in a 2.5-square inch-area.<sup>19</sup> Professor Lambertus Hesselink's work with optical fibers of strontium barium niobate suggests that one million bits of data can be encoded on a rod smaller than a straight pin.<sup>20</sup> He plans for an array that handles 120 gigabytes in one square centimeter within the next few years.<sup>21</sup> Supercooled plasma memories are predicted to provide multiple terabytes in one-square- millimeter-size storage units while theorists suggest that molecular<sup>22</sup> or deoxyribonucleic acid (DNA)<sup>23</sup> memories and processors will put a terabyte in an area the size of a grain of salt.<sup>24</sup> Negroponte and Gates argue that growth in memory is driven today by the commercial sector, and society (military, government, and education) will ride upon their coattails, gaining virtually unlimited memory storage capacity in miniature form.<sup>25</sup>

1 gigabyte of holographic memory  
1996



120 gigabyte barium niobate fiber  
holographic memory - 1998



Terabyte + plasma memory  
2005



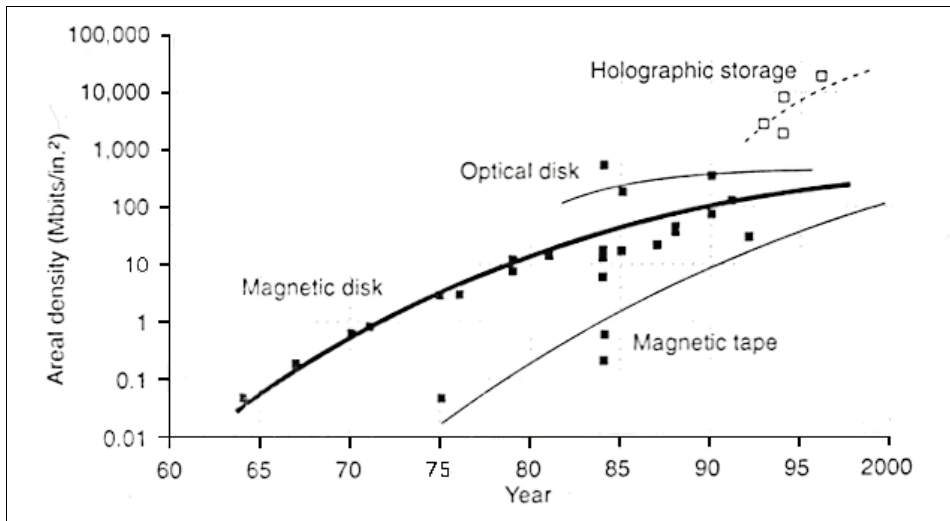
100 terabyte molecular or DNA  
memory - 2025



Note: 1 Terabyte is equivalent to 1,000 gigabytes or 1,000,000 megabytes

**Figure 3-8. Comparison of Data Storage Capacity and Size**

Achieving high levels of areal\* density is a key component of both storage and speed,  
as shown in figure 3-9.<sup>26</sup>

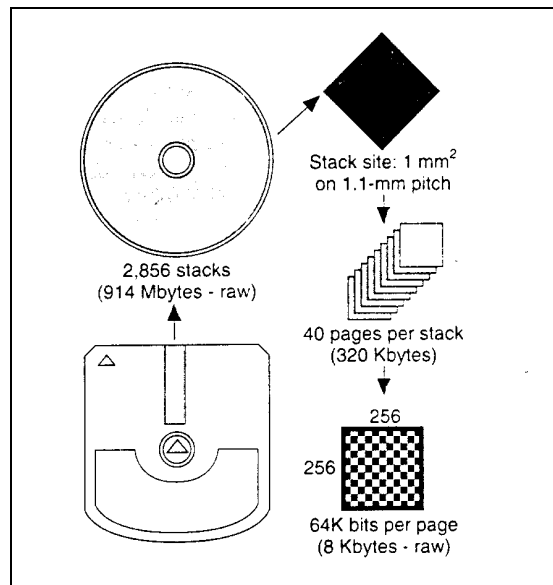


Source: John Stockton, "Portable Electronic Storage Systems," *IEEE Micro* 14, no. 1 (February 1994). Reprinted with permission ©1994 IEEE Micro.

**Figure 3-9. Advances in Areal Density**

\* *Areal density* is a term which relates to the amount of data that is stored in close proximity. The more that is "packed" into a two-or three-dimensional space, the more efficient and effective the memory system.

Holographic media are most efficient in maximizing this feature, using optical storage and retrieval systems. Simultaneous reading and writing of “pages” of data and multiplexing<sup>27</sup> allows storage of large numbers of pages in the same location.<sup>28</sup> Consequently, saving and accessing data is much quicker.<sup>29</sup>



**Source:** John Stockton, “Portable Electronic Storage Systems,” *IEEE Micro* 14, no. 1 (February 1994). Reprinted with permission. ©1994 IEEE Micro.

**Figure 3-10. Example of Holographic Memory Array**

Holographic design not only improves speed, it also allows processing within memory.<sup>30</sup> Given the delays experienced when accessing a large spreadsheet or database and the processing time needed to make changes, it is understood that processing within memory means that calculations and modifications occur continuously and are totally transparent to the user. Random access memory (RAM) is freed up so transitions, by virtue of their speed, are seamless. A further advantage is that optical data storage creates physical changes in the medium and, therefore, holographic memory systems are more resistant to electromagnetic pulses than magnetic memory.<sup>31</sup> The Air Force’s Rome

Laboratory is actively pursuing advanced holographic memory designs while Tamarack Industries is the leading-edge commercial developer today.

### **Real-time Decision Support/Artificial Intelligence (AI) Software**

Turning mountains of data into usable “point” information drives the ability for complex analysis and application of highly advanced artificial intelligence architectures. These systems must combine inputs from multiple sources; identify significant changes and anomalies; determine critical indicators for alert reporting; and generate highly reliable products. Rome Lab, in collaboration with the Advanced Research Projects Agency and other Department of Defense (DOD) laboratories, is addressing this area through multiple product lines, and has fielded some limited systems (e.g., the advanced planning system installed as a component of the contingency tactical air control systems automated planning system [CTAPS]).<sup>32</sup> Advanced technology demonstrations are ongoing with the joint strategic targeting and reconnaissance system (JSTARS) for cueing and correlation and for several other data- and image-processing and display programs.<sup>33</sup>

While this work is important, a great deal of artificial intelligence and processing design can be culled from the civilian sector and then adapted for military use. The current military literature on data fusion is still speaking of improving the “blips” on radar screens,<sup>34</sup> but the war fighter of the future needs fully articulated visuals and an intelligent, interactive machine interface which alerts and advises, not one that just reports. Monte Zweben’s processing and scheduling control system for National Aeronautics and Space Agency’s (NASA) Kennedy Space Center optimized the complex parallel tasks of shuttle launching and maintenance, generating substantial savings in time

and money. Using multiple sensors and applying proactive data processing, analysis, and artificial intelligence (AI) modeling to the business world, his Response Agent™ system optimizes manufacturing processes based on changes within the system.<sup>35</sup> This decision-support software uses a theory of constraints approach<sup>36</sup> and has become the “smart” expediter for diverse manufacturing processes. Although Lenat indicates that AI progress has been disappointing since its inception in 1956, he believes that “artificial intelligence stands on the brink of success.”<sup>37</sup> Software modules for military simulations still require military investment.<sup>38</sup>

### **Image Understanding Software**

The ARPA has created the Image Understanding Program for the Department of Defense; two projects within the program are Radius (Research and Development, Image Understanding Systems) and UGV-RSTA (Unmanned Ground Vehicle-Reconnaissance, Surveillance and Target Acquisition).<sup>39</sup> The former is focused on image intelligence, and the latter is an enabler for unmanned aerial vehicles in targeting. Image recognition programming advances are currently inadequate in the commercial sector. The advanced fractal analysis and complex algorithms required for the highly accurate, multimodal system envisioned for VIPERS are not yet available and require continued development.<sup>40</sup>

### **Human Machine Interfaces**

Commanders access VIPERS through a natural human interface. Their voice, eye movements, and gestures are interpreted by VIPERS’s communications sensors and

directly integrate with its functions.<sup>41</sup> The commercial sector already recognizes voice, and language systems have a strong market demand. According to Lucente, “This is the year of commercial speech recognition and commands”; dramatic improvements will be seen by the year 2000.<sup>42</sup>

Researchers at the Massachusetts Institute of Technology (MIT) Media Lab are working on the gesture and eye-movement components of a natural human-machine interface; working in conjunction with their ARPA/Rome Laboratory sponsored C<sup>3</sup>I battlefield project they have successfully fielded a system which uses a glove to pick up hand motion and a camera for eye movement.<sup>43</sup> Several military labs, including Rome and the Naval Research Lab, have projects on line while the intelligence services are taking systems a step farther by adding translators.<sup>44</sup>

The Naval Research Laboratory’s Intelligent M<sup>4</sup> Systems Group is examining the linguistics of spatial relations when a user interacts with a computer-based map display. The testbed for this so-called InterLACE (Interface with Land Air Combat in Eric) project is Rome Laboratory’s LACE (Land Air Combat in Eric) combat simulation system. It is combined with a natural language processor to allow querying of routes and directional orders for a simulated tank unit as it traverses three-dimensional terrain.<sup>45</sup> This militarily focused effort begins to link some of the key technologies for VIPERS as it integrates a geographic database with an artificially intelligent medium and offers verbal order execution in a three-dimensional simulation.<sup>46</sup>



### **Three-Dimensional Holographic Display**

For commanders and their staffs to interactively plan and execute, they will rely on a system which ties a number of technologies to the holographic engine. This involves wargaming software, verbal tasking order generation coupled with automated resupply, and other support functions based on mission requirements.

The essential technologies for the holographic component of VIPERS include portable projection devices, which have greatly increased capability for generating large, complex images and eliminating need for display media. In 1994 Dimensional Media Associates generated full-color moving images which appeared suspended in the air outside a building. Current technology allows 120° view angle and image size from a few inches to 20 feet. A 360° projection capability is expected in the near term.<sup>47</sup> Although current technology limits real-time, interactive three-dimensional holograms to 150 mm wide by 75 mm high by 160 mm deep, developers are predicting “big as an elephant” displays in the lab setting by 2020.<sup>48</sup> These projections will incorporate the desirable AI features without the restrictive trappings of today.

The key need to generate interactive holographic images in near real time is also partially addressed by emerging holographic movie technologies. The technology is currently constrained by short projection times, monochrome images, and the need for supercooled (7K) operating temperatures. Nippon Telephone and Telegraph designers are predicting storage capability of 10 million still pictures/100 hours of broadcast with a recording system able to capture one frame per nanosecond.<sup>49</sup>

The recreational market for virtual-reality systems is bearing fruit with potential application to the holographic battlesphere. Dr Pattie Maes of MIT Media Labs, while

working without DOD sponsorship, has focused on ALIVE (Artificial Life Interactive Video Entertainment), a “no wires” virtual world with smart, sensing, autonomous agents that interact with visitors.<sup>50</sup> In 1996, virtual-reality interfaces also help stock and commodities traders perceive changing markets in a way that lets them make faster, more accurate judgments on trends and relationships.<sup>51</sup> Fully holographic media may not be desirable in the field setting, and hand-held devices which use a variant of the master system are likely to be both cheaper and easier to deploy.<sup>52</sup> Image projection may employ transparent holographic visors, similar to head-up displays.<sup>53</sup> The commercial applications for these devices include automobile designs and medical systems.<sup>54</sup>

Negroponte claims that in the future we will watch in our living room football games played by small holographic figures who run around on the carpet.<sup>55</sup> This level of commercial development and broad application of holographic technology is not likely to occur by 2025 without large infusions of capital.<sup>56</sup>

The following chapter reveals systems operation, the concept of operations, and the absolute utility of the proposed system. For now though, what do we know about VIPERS? VIPERS provides decision makers, at all levels of command, with a knowledge-based tool enabling rapid operations and support planning.

VIPERS allows decision makers to integrate political conditions and end states with the required intelligence information and force structures to achieve it. Along the way, sophisticated technologies allow operations and support planners to visualize the relevant environment, consider wargame options, and issue logical logistical, deployment, and operations orders to those charged with mission accomplishment. The end result is an

overarching, fully integrated plan that is entirely feasible, within whatever constraints relevant decision makers have placed upon it.

## Notes

<sup>1</sup> David Hughes, "MITRE, Air Force Explore Data Fusion for Joint-STARS," *Aviation Week and Space Technology* 140, no.10 (7 March 1994): 47–48. The table in Appendix A summarizes the methods of fusion and integration for various databases. Further, the table illustrates the ways and means to provide useful information by critical analysis.

2. *2025* Concepts, No. 900182, "Neuro-network Computer Interfaces" and No. 200191, "Neural Interfaces," *2025* Concept database (Maxwell AFB, Ala.: Air War College/*2025*, 1996).

3. *2025* Concepts, No. 901148, "Voice Command Systems," *2025* Concept database (Maxwell AFB, Ala.: Air War College/*2025*, 1996).

4. *2025* Concepts, No. 900161, "Holographic C<sup>2</sup> Sandbox," *2025* Concept database (Maxwell AFB, Ala.: Air War College/*2025*, 1996).

5. Bill Gates, Nathan Myhrvold, Peter Rinearson, *The Road Ahead* (New York: Viking Press, 1995), 73–77. Gates discusses the wallet computer, which can display maps, communicate, and perform a multitude of other functions, plus is capable of sending and receiving fully encrypted material.

6. Dr Pattie Maes, "Intelligent Software," September 1995, n.p.; online, Internet, 11 March 1996, available from <http://pattie.www.media.mit.edu/people/pattie/SciAm-95.html>.

7. Ibid.

8. USAF Scientific Advisory Board, *New World Vistas: Air and Space Power for the 21<sup>st</sup> Century*, executive summary (Washington, D.C.: USAF Scientific Advisory Board, January 1996).

9. "Milestones," Online. Available protocol: <http://www.nanothinc.com/cgi-bin/imagemap/navigationbar?186,18.>, 24 June 1996.

10. Dr Mark Lucente (lucente@watson.ibm.com), "Subject: Air Force/Air Power 2025, E-mail to Maj Barbara Jefts (bjefts@max1.au.af.mil), 23 March 1996.

11. Nicholas Negroponte, *Being Digital* (New York: Alfred A. Knopf, 1995), 29.

12. Tim Stevens, "Holograms: More than Pretty Pictures," *Industry Week*, 4 October 1993, 37. Broadcast-quality video requires 30 video frames per second. In each frame there are approximately 922 kilobytes of data. Multiplying 922 kB per frame by 30 frames per second yields 27,660 kB per second (John F. Stockton, "Portable Electronic Storage Systems," *IEEE Micro* 14, no. 1 [February 1994]: 71); therefore, 30 MBPS data-transfer rate is rational basis for forecasting broadcast video requirements.

## Notes

13. Dr Mark Lucente (lucente@watson.ibm.com), "Subject re: Air Force/Air Power 2025," E-mail to Maj Barbara Jefts, (bjefts@max1.au.af.mil), 21 March 1996.

14. Negroponte, 107.

15. "Personnel Identification Friend or Foe (IFF)," Concept 200021, 17 November 1995; "Gnat Threat Detector," Concept 200231, 11 October 1995; "Surveillance Swarm," Concept 200023, 20 November 1995; "Electronic Grid Throw Away Sensors," Concept 900518, 27 November 1995; and "Space AWACS Concept," Concept 900678, 5 December 1995.

16. Dr Kaigham J. Gabriel, "Engineering Microscopic Machines," *Scientific American* 273, no. 3 (September 1995): 119.

17. *Ibid.*, 118.

18. *Rome Laboratory FY95 Command Control Communications and Intelligence C<sup>3</sup>I Technology Area Plan* (Wright-Patterson Air Force Base, Ohio, Headquarters Air Force Materiel Command, June 1994).

19. *Ibid.*, 72.

20. "Untangling the Data Traffic Jam," *USA Today* 121, no. 2577 (June 1993): 8.

21. Philip E. Ross, "The Hologram Remembers," *Forbes* 54, no. 7, (26 September 1994): 170.

22. Gates et al., 21–34.

23. The complex genetic codes found on DNA are actually memories. The chemical structure can be replicated and thus is a reproducible, "readable" memory. Genetic engineering advances may allow DNA creation in the future as they allow "gene splicing" and chromosome repair today.

24. Sunny Bains, "Plasma Holograms Pack in the Memories," *New Scientist* 145, no. 1968, (11 March 1995): 22. The *New World Vistas* paper discusses petabyte capacities for computation.

25. Gates et al., 31–34; and Negroponte, 208.

26. John F. Stockton, "Portable Electronic Storage Systems," *IEEE Micro* 14, no. 1 (February 1994): 72. If high density is achieved, minimal time is lost accessing and transferring data from memory to application for processing. Literally packing the bits of data in a three-dimensional array, it reduces this time significantly as well as allowing other unique functions.

27. Multiplexing is a process of optically storing data by changing the angle of the laser used to write the data into the memory and then literally stacking the memory crystals

28. Ross, 173–74.

29. Stevens, 37.

30. Ross, 174.

## Notes

31. Maj Greg H. Gunsch, Air Force Institute of Technology, telephone interview with Maj Barbara Jefts, 3 April 1996.

32. *Rome Laboratory FY95 Command Control Communications and Intelligence C<sup>3</sup>I Technology Area Plan*, 5–6.

33. *Ibid.*, 6. Appendix A also provides a reference table which presents the multitude of fusion approaches being used in the development of these systems.

34. The status of current fusion projects for the airborne warning and control system (AWACS) and JSTARS is addressed in two articles by David Hughes. “AWACS Data Fusion under Evaluation,” *Aviation Week and Space Technology* 140, no. 10 (7 March 1994): 62–63 and “MITRE, Air Force Explores Data Fusion for Joint-STARS,” *Aviation Week and Space Technology* 140, no. 10 (7 March 1994): 47–48.

35. John Teresko, “Red Pepper Software—Bringing Real-time Planning and Scheduling to Manufacturing,” *Industry Week* 244, no. 23 (18 December 1995): 27. Monte Zweben’s work at the NASA Ames Research Center was directly responsible for improvements in the shuttle maintenance and repair which translated to shortened periods between launches.

36. Theory of Constraints process modeling allows you to identify those subprocesses or whole processes which, if improved, will directly impact overall system performance. The user defines the outcome measures which are most important (e.g., profit, time, quality of product, etc.), and the model will expose the components of the system which play the biggest role in achieving those goals. Once a constraint is overcome, the model reveals any new constraints which may have developed because of the change in the system and highlights other process choke points.

37. Douglas B. Lenat, “Artificial Intelligence,” *Scientific American* 273, no. 3 (September 1995): 62.

38. USAF Scientific Advisory Board, *New World Vistas: Air and Space Power for the 21<sup>st</sup> Century* (unpublished draft, the information applications volume, 15 December 1995), 9.

39. Oscar Firschein, “Defense Applications of Image Understanding,” *IEEE Micro*, October 1995, 11.

40. Peter Wayner, “Machine Learning Grows Up,” *BYTE* 20, no. 8 (August 1995): 63.

41. “Neuro-network Computer Interface,” Concept 900182, 25 September 1995; and “Neural Interfaces,” Concept 200191, 4 January 1996.

42. Dr Mark Lucente (lucente@watson.ibm.com), “Subject: Air Force/Air Power 2025,” E-mail to Maj Barbara Jefts (bjefts@max1.au.af.mil), 6 March 1996; and “Voice Command Systems,” Concept 901148, 1 February 1996.

## Notes

43. Mona Toms and Gilbert Kuperman, "Sensor Fusion: A Human Factors Perspective," Research Report (Wright-Patterson AFB, Ohio) Armstrong Laboratories, Air Force Systems Command, 1991, 63.

44. *Rome Laboratory FY95 Command Control Communications and Intelligence (C<sup>3</sup>I) Technology Area Plan*, 17–19; Stephanie S. Everett, Kenneth Wauchope, and Manuel Perez, "A Natural Language Interface for Virtual Reality Systems", online, Internet, available from <http://www.nrl.navy.mil>, 4 March 1996; and 2025 concept, no. 900341, "Universal Translator," 2025 concept database (Maxwell AFB, Ala.: Air War College/2025, 1996).

45. Kenneth Wauchope, Navy Center for Applied Research in Artificial Intelligence, InterLACE project, online, Internet, available from <http://www.aic.nrl.navy.mil/~wauchope/interlace.html>, 4 March 1996; and "LACE", Rome Laboratory, online, Internet, available from <http://www.rl.af.mil:8001/technology/summary/summary.html>, 7 April 1996.

46. Charles Arthur, "Holographic Movies Come in from the Cold," *New Scientist* 142, no. 1931 (25 June 25 1994), 21.

47. Ron Goldberg, "How Much Is That Image in the Window," *Popular Science* 246, no. 2 (February 1995), 42.

48. Lucente, "Subject re: Air Force/Air Power 2025," 6 March 1996.

49. Arthur, 21.

50. Pattie Maes, "Artificial Life meets Entertainment: Interacting with Lifelike Autonomous Agents," *Communications of the ACM* 38, no.11, November 1995, n.p.; on-line, Internet, 11 March 1996, available from <http://www.acm.org/pubs/cacm/> and Maes, "Intelligent Software".

51. David Baum, "Assets in Wonderland," *BYTE* 20, no. 7 (July 1995): 111–12. The system described vrTrader<sup>TM</sup> operates on a Windows PC; uses live data feeds from Cable TV, FM, or satellite; and generates a 3-D color display with optional voice recognition and spatial sound capability .

52. Lucente, "Subject re: Air Force/Air Power 2025," 6 March 1996; and Nicolas Negroponte and Dr Richard A. Bolt, "Advanced Concurrent Interface for High-Performance Multimedia Distributed C<sup>3</sup> Systems," Research Report, (MIT Media Lab, March 1993), 34.

53. Robert Langreth, "A 2-D Display is Better Than 3," *Popular Science* 244, no. 5 (May 1994): 53; and "Tactical Information Display Helmet," Concept 900317, 27 October 1995.

54. "Disc Drivers," *The Economist* 335, no. 916 (27May 1995): 74; "3-D CT," *Discover* 13, no. 8 (August 1992): 10; and Andrew A. Skolnick, "New Holographic Process Provides Noninvasive, 3-D Anatomic Views," *JAMA* 271, no. 1 (5 January 1994): 5.

## Notes

55. Negroponte, 107.
56. Lucente, "Subject re: Air Force/Air Power 2025", 6 March 1996.

## Chapter 4

### Concept of Operations

A way of visualizing VIPERS is to think of it as the “holodeck” of *Star Trek: The Next Generation* married to the offspring of the global command and control system (GCCS). Since the full range of VIPERS’s capabilities is difficult to convey in the print medium, this chapter presents a fictional scenario as an aid to understanding how the system might operate and follows with a discussion of how VIPERS’s attributes compare to the measures of merit identified in Chapter 2. Finally, the chapter enumerates possible countermeasures and strategies to overcome them.

### Operation Zion

Dateline: 7 Mar 2025 0300Z Jerusalem

The peace established in 1999 by Yasser Arafat and President Peres broke sharply today when an insurgent group called the New Palestinian Liberation Organization seized temples throughout the Holy City. This well-armed group has infiltrated all the major cities in Israel, taking numerous hostages, and is occupying parliamentary buildings in Tel Aviv. The group claims to have chemical and biological weapons ready to detonate if the standing forces of Palestine or Israel try to intervene in either city. This unprecedented action has stymied the Mossad. The current presidents of both Israel and Palestine have appealed to the United States for help; additional pressure for immediate action is being generated by special interest groups within the United States.

071300Z MAR 25 (Vicenza IT) - Commander-in-Chief Mediterranean region, General Miller, receives an urgent tasking from the NCA to prepare alternate courses of action in dealing with this crisis. His plans must be sensitive to the cultural and religious



interests of the parties, consider use of ad hoc coalition forces, and *be ready for discussion at a special meeting of the National Security Council (NSC) 1800Z*. The formal operations plans for his region do not address this contingency, but he is unflustered as he brings his planning staff together.

071400Z MAR 25 - General Miller joins the group in the VIPERS's Planning Center. The lights dim; the holodome automatically responds to the J-2's description of the events in Israel by creating a 3-D image of the eastern Mediterranean region. Glowing icons show the location of all friendly air, sea, and ground forces within 200<sup>1</sup> miles of the area of operations (AO). Real-time imagery displays the known locations of insurgents' action and their order of battle as General Miller walks around his theater. At his request, VIPERS provides an audio-video review of current national security strategy for the Middle East and highlights pertinent political objectives and constraints of the present administration.

The planning group works through four courses of action (COA) in two hours. VIPERS has analyzed each one for adequacy, acceptability, feasibility, and compliance with joint/combined doctrine. By wargaming the options through the medium of holography, the team has been able to see the phases unfold and gauge the resultant end states for each. VIPERS artificial intelligence warrior function has also suggested alternatives and allowed simultaneous imbedding of branches and sequels. General Miller quickly evaluates each COA on its merits while VIPERS objectively rates them on probability of success, casualty figures, supportability, and expense factors. VIPERS concurrently generates command and unit taskings, optimizes deployment and combat scheduling, and completes the transportation planning needed for the operations. General Miller asks the VIPERS Planning Center to contact Chairman, Joint Chiefs of Staff, General Sterling, so he can be briefed on the situation and military options for action.

071600Z MAR 25 (Washington, D.C.) Within minutes, Chairman Sterling is ready in his holosuite along with a few key members of his staff. General Miller has VIPERS present the current situation with selected imagery and real-time force estimates. The chairman asks for, and immediately receives, additional details on biologic and chemical munitions countermeasures. Both staffs see the same images and move through them as the suggested courses of action play out. The entire process takes less than an hour. The chairman concurs with General Miller's suggested approach, but wants to give Secretary of Defense Pidgeon an opportunity to fine tune objectives, constraints, and possible rules of engagement (ROE) prior to the National Security Council (NSC) meeting.

071715Z MAR 25 (Washington, D.C.) - Secretary Pidgeon reviews the plan through a 3-D desktop display monitor while looking over the president's most recent foreign policy guidance. After the secretary dictates a few ROE changes and suggests an alternate deployment day, VIPERS gives an updated assessment of the merits of each COA and cost estimates for the operation. Satisfied, Secretary Pidgeon heads for the NSC meeting room.

071845Z MAR 25 (Washington, D.C.) - The meeting went well; the White House press are demanding a statement as soon as the president leaves the room. She doesn't

even pause in her stride as she continues on her way saying, “We’ve already downloaded our official position to your servers, including statements from the presidents of both Israel and Palestine. You can expect daily updates from General Miller’s office as well as the White House situation room on Operation Zion.”

071900Z MAR 25 (Worldwide) - Tasked units from all services are receiving their orders for deployment. Logistics plans are complete and plans to phase into the theater are set. Host nation support capabilities have been factored in and basing requirements established. Final training recommendations have accompanied the orders so units/individuals can visit their simulators for AO familiarization training and joint/combined training, techniques, and procedures review.<sup>2</sup> Secure video links with the Israelis and Palestinians have allowed full discussion of the coalition effort, and they too are readying their forces with the help of VIPERS. Operation Zion is underway.

101300Z MAR 25. (Tel Aviv) - Seventy-two hours later, Colonel Dautry, 366 WG/CC, is moving toward the expeditionary wing operations center in Tel Aviv. The colonel, accompanied by the group commanders, intends to review the wing’s mission and the various adversary orders of battle. VIPERS quickly provides the required data and information as the wing intelligence officer talks. Lacking the holographic projection dome, the system formats the presentation for wall-mounted display. Colonel Dautry is instantly shown the location of the wing’s aircraft as they close on the isolated, recently constructed, airbase in the Negev Desert. Additionally, the progress and location of air- and sea-borne supplies are monitored via a real-time moving map. The system also pinpoints the location of the security police forces that will provide air base defense. Having reviewed all the relevant data, Colonel Dautry directs the air tasking order (ATO) be transmitted to the base in the Negev. The ATO completed, Colonel Dautry and staff prepare to move forward to join the wing on arrival at the deployment location.

Across the base, Lieutenant Colonel Lance uses VIPERS to evaluate the security sphere surrounding the airbase in the Negev. She reviews the location and disposition of her security forces and then requests a detailed report on all personnel located at the airbase, ensuring that all deployed individuals have their personal transmitters. VIPERS compares the real-time data uplink with its archived personnel deployment data and generates a display that positively identifies the location of all assigned personnel. The addition of physiological parameters and fitness-for-duty estimates in the display allows Colonel Lance to detect a sentry on the west perimeter asleep on duty. She uses VIPERS to alert the area supervisor to the condition and links back to her stateside judge advocate general (JAG) to assure correct Article 15 procedures are followed. Further, she calls up a subterranean schematic of the base’s sewer system to ensure all access routes to the base are observed and defended.

121500Z MAR 25 (Negev) - Combat operations commenced at 1300Z. VIPERS detects an attempted incursion 500 meters outside the northern base perimeter by three unidentified personnel (UP). It immediately alerts the ground defense operations center and the sentries in the affected sector. The system provides precise location, equipage, and direction of movement of the UP and then assesses the threat based on localized sensor observation.<sup>3</sup> Following this engagement, VIPERS provides Colonel Lance with

an updated evaluation of the base security posture reflecting the current threat assessment and recommends three additional sentries be added to the northwest perimeter.

If the scenario continued, it would merely add more detail regarding VIPERS's specific processes and outputs. The powerful system has integrated and automated the majority of planning, execution, and evaluation of military requirements. VIPERS freed human decision makers and empowered them to think creatively, unencumbered by the myriad of details which accompany complex operations. Some critics might argue that using artificial intelligence to assist in planning inherently creates a vulnerability because the machine is predictable. An alternate view is that humans are as likely as machines to have predictable decision-making and response patterns. Intelligent agents may help overcome this weakness. VIPERS's incorporation of AI does not subsume creativity, but instead improves the commander's capability by reducing or eliminating other taskings. VIPERS also adapts to the user's eccentricities rather than requiring the user to adapt to the system, as in today's systems.

As discussed in Chapter 2, synchronized support to combatants is critical to success. VIPERS generates this capability, puts commanders in control of processes, and is designed to avoid dependency on a separate "push" type intelligence/information architecture. VIPERS produces the type of "point answers"<sup>4</sup> commanders require during crisis planning.

All of VIPERS's users accessed the same "system of systems," but its displays and products were individually tailored. The NCA viewed Operation Zion from the strategic level; the theater CINC focused on operational concerns for planning, deployment, lodgment, and employment; while the security police commander used both tactical and

administrative functions, in response to quickly changing conditions. VIPERS provided a comfortable human–machine interface in the overall process for all users.

The system supports demassifying the battlespace through its robustness at all levels of command. When fully operational, it should allow simplification of command structures and effectively reduce the number of planning and support personnel required. Coupling VIPERS’s capabilities with new force structures allows information supremacy and addresses a significant constraint of the world envisioned in 2025. By using VIPERS, we will place fewer forces in harm’s way: the system allows effective military action and deals with US citizens’ intolerance of casualties. It also makes rapid victory possible in this high-tech environment.

### **Attributes and Measures of Merit**

Why VIPERS? First, the observing and analysis feature of the system hardens friendly forces’ OODA loop.<sup>5</sup> Plans, decisions, and actions occur rapidly and precisely with insight into the adversary’s movements. In similar fashion, the observation, analysis, and prediction features of VIPERS reveal an enemy’s weaknesses and possible intent. Finally, VIPERS removes safe havens from the enemy by extending the sensory and conceptual horizon of the war fighter, fostering a paralyzing tempo and inhibiting the adversary’s ability to recover. VIPERS aids friendly forces in imposing chaos on the opponent.<sup>6</sup>

Throughout this paper, we have shown how VIPERS, using new conceptual frameworks and advanced technologies, will provide a significant improvement over the system of systems developing today. VIPERS is not just an omniscient system or a

sophisticated war-gaming system; it is an architecture that uses common standards across intelligence, surveillance, and reconnaissance (ISR) and C<sup>4</sup>I systems. It melds these systems with technology advances to produce uncommon capability. Some may argue that VIPERS may be a reality within 10 years; however, experience has shown that technology promises are rarely accurate. Given the fiscal constraints of today, as Negroponte argues, cost and funding will drive progress more than technological feasibility will.<sup>7</sup>

Measurable improvement is realized in the ability to survive, plan, decide, communicate, control, and integrate. VIPERS demonstrates survivability in terms of the percent of the network surviving after attack as well as the survival of any single node.

Planning is measured by effectiveness and efficiency. Effectiveness speaks to how the system enables the commander and staff to generate a plan in terms of congruence with objectives, feasibility of courses of action, and required logistics support. The effects of course of action simulation provide rapid feedback that allows anticipation on the battlefield. Effectiveness of operations improves through war gaming and automated “what if” analysis. Efficiency refers to how the system aids planners in accomplishing the planning task (i.e., time required, man-hours, etc.). VIPERS’s visibility of assets and display of all-source intelligence reduce the time and effort consumed in chasing information essential for detailed planning.

Timeliness and quality are the defining measures of merit for decision making. VIPERS improves any decision with regard to speed, accuracy, and risk through the integration and inclusion of capabilities previously discussed.

The ability to communicate is measured, in order of importance, as reliability, security, connectivity, capacity, user friendliness, and human interaction. Reliability or data accuracy is the percentage of data received correctly from the sender. Security is the amount of data, as a percentage, protected by the system. Connectivity or interoperability is the percent of relevant knowledge. Capacity is defined as the size of the “pipes” in gigabytes per second. User friendliness describes the ability of the human to interact naturally with the system; further, user friendliness encompasses an element of human-to-human contact that is facilitated by the system. Interaction may take the form of the written word, voice, video conferencing, or mental telepathy.

Control speaks to the system’s ability to track and task personnel and materiel. It is measured as the percent of assets visible to the commander. VIPERS significantly improves process control because it seamlessly integrates tracking of assets using MEMS technology, archived information, and high bandwidth communications between databases.

Integration combines speed, battlespace view, and correlation. Speed is judged with regard to arriving in time for integration into the decision process. Battlespace view refers to the percent of relevant data displayed. Correlation is the degree of agreement between the system and historical norms. VIPERS compares favorably with these criteria because of capabilities previously discussed.

### **System Countermeasures**

VIPERS will be a natural center of gravity for a potential enemy and is susceptible to attack at the distributed databases, transmission sources, and projection/display system.

While we recognize that any inventive enemy can discover numerous ways to attack, what follows is a sample of what an enemy might do. First, the enemy can attempt to corrupt archived data, making the data incorrect or inaccessible. In addition, an enemy could attack the links between the databases, also denying access.

Secondly, false data can be interjected (deception), compromising our ability to observe and understand. For example, an enemy might cause VIPERS to provide an indication of no air threat when an enemy strike package is actually ingressing; insert information identifying enemy forces as friendly; or cancel orders for critical logistical support. Undetected false data would also be archived, further corrupting system integrity.

A third method of attack is exploitation. An enemy could surreptitiously intercept information of our plans or operations and use it to counter our actions. A historical precedent for this is the Allies' use of broken codes to help defeat the Axis powers during World War II.

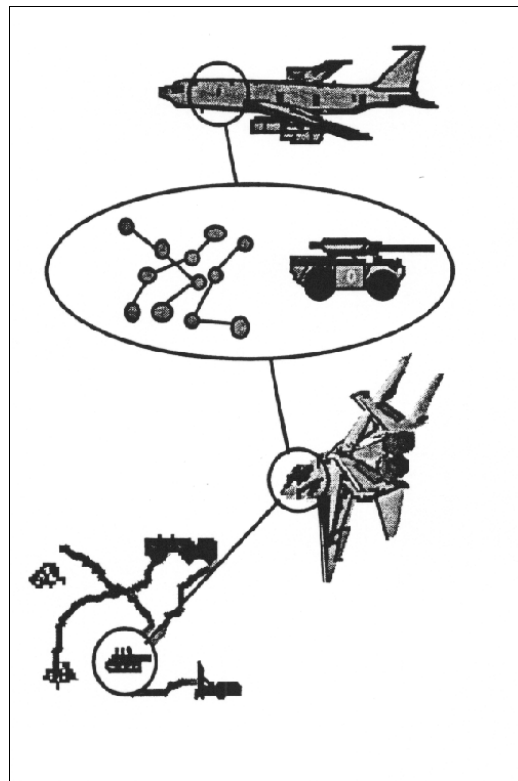
A fourth avenue of attack would be the system's physical destruction. An enemy could attack a VIPERS node or selected nodes with a variety of weapons platforms, including precision guided munitions, ballistic or cruise missiles, or directed energy weapons.

### **Strategies to Counter Enemy Attack**

Continued focus on education, leadership, and doctrine is paramount for the successful implementation of VIPERS. If allowed, VIPERS will tend to produce cognitive dependence in our future leaders. Leader training and education must counter

this dependency, sustaining the capacity for decision making in the absence of VIPERS's capability.

VIPERS's integrated sensor architecture, as shown in figure 4-1, and distributed databases would require any enemy to possess the capacity for massively parallel and simultaneous attack. VIPERS, as a complex system, has no single-point failure and is inherently self-adapting. The expected low cost of bandwidth coupled with widespread massive databases prevents a single shot or a few attacks from crippling the system. This counter is similar to the capability of today's publicly switched network to reroute phone service throughout the nation.



**Figure 4-1. Integrated Sensor Architecture**

Central to VIPERS's capability is the connectivity between distributed databases. In addition, VIPERS integrates and archives the output of numerous broadcast sensor



networks. For example, MEMS programmed to sense seismic activity over a broad area would be difficult to interdict, due largely to the numbers employed relative to their very small size. Destruction or disruption of any sensor in the sensor field will alert the system that an attack or activity is in progress. Attempts to navigate the sensor field would also be detected, forcing the adversary to bypass known sensor fields, thereby producing yet another detectable signature.

The layering of VIPERS's databases produces a natural comparative environment within the archive. Each database must maintain a logical relationship over time and within historical, logical parameters. The intelligent assistant features of VIPERS assist and alert users to deviations from the chronicled or time-indexed norms.

Real-time data will also be compared: observation to observation and observation to archive. Comparative analysis minimizes the opportunity for an adversary to interject meaningless or false data into the OODA loop.

Use of fiber-optic links and cellular-packet technology, combined with the multiple frequencies and transmission mechanics between nodes and databases, will make it difficult for unauthorized users to extract information from the bit stream. Logical encryption will further complicate the extraction effort. Some data will come to the user naturally encrypted. Examples are SIGINT, photographic intelligence, intelligence analysis, logistical status, force status, and orders of battle.

By logical encryption, we are describing the encryption of the value-added portion of the decision cycle. There is no reason to encrypt data that is universally available, such as National Oceanographic and Atmospheric Agency weather data, or topographic and geodetic data. Under most imaginable circumstances, encryption of the output will be a

necessary precaution. Encryption, a by-product of commercial enterprise, will form the backbone of military information security methodologies. Very large prime numbers provide the encryption basis for secure financial transactions in the future.<sup>8</sup> Systems using these very large primes--RSA 129 and greater--will likely safeguard military communications in 2025.

The last security topic is physical security. Recall that each individual will have a personal monitoring chip. Physical security to prevent unauthorized use of the projection devices or access to the VIPERS's databases will be a combination of personal status reporting (are you alive and still authorized?) and voice and thumb-print recognition. This capability will allow multiple authorized users access to the databases and projection capabilities of a single device. New user access (the operations officer, because his broke) will be accomplished by way of personal status reporting and iris/retina scan recognition to validate user authorization.

### Notes

1. Adm William A. Owens, "The Emerging System of Systems," *Proceedings*, no. 5 (May 1995): 35.
2. Joint Publication 0-2, *Unified Action Armed Forces (UNAAF)*, *Joint Chiefs of Staff*, (Washington, D.C.: United States Government Printing Office, 24 February 1995), I-8.
3. Col M. Scott Mayes, et al., "Aerospace Sanctuary in 2025," unpublished white paper, Air Force 2025 Study, Air University, Maxwell Air Force Base, Ala., undated.
4. 2025 advisor's meeting, Air University, Maxwell AFB, Ala., 24-26 March 1996.
5. John Boyd, "A Discourse on Winning and Losing," August 1987, Unpublished briefings and essays (Air University Library, Maxwell AFB, Ala., document M-U 30352-16, no. 7791), 5.

## Notes

6. Maj Glenn James, “Who Needs Chaos Theory,” in *Theater Air Campaign Studies Course Book* (Maxwell AFB, Ala.: Air Command and Staff College, 1996), 31.
7. Nicholas Negroponte, *Being Digital* (New York: Alfred A. Knopf, 1995), 31–35.
8. Bill Gates, Nathan Myhrvold, and Peter Rinearson, *The Road Ahead* (New York: Viking Press, 1995), 65.

## **Chapter 5**

### **Investigation Recommendations**

To fully develop the virtual integrated planning and execution resources system, further research and funding of key technologies is essential. The Air Force is aggressively pursuing many of the necessary technological advances for VIPERS. The problem is getting the various systems, which are currently developed in stove-piped manners, to integrate into a single whole. The commercial marketplace is driving the technological advancement of the future. The military must be more proactive and knowledgeable of commercial developers who provide the tools of tomorrow. It is more important for the armed forces to use emerging capabilities than to develop the technologies. In other words, the military must spend more effort in massaging commercial developments than in creating its own.

The Air Force needs smart, user-adaptive interfaces, supported by appropriate software agents, and display technologies such as large screen display and three-dimensional holographic systems. Intelligent agents must aid the human-machine interface. Research is being aggressively pursued by MIT, IBM, Navy Research, and Rome Labs in these areas, but requires further funding to foster long-term development. Image-understanding programs which will allow timely, seamless integration of

intelligence into the system need a significant push in the military realm. More than anything else, though, we must integrate information system components into a system of systems that will support the goals, objectives, and missions of the armed forces.

## Appendix A

### Automated Analysis and Summary of Fusion Techniques

Method	Kernel Process	Character of Input	Character of Output	Range of Application
Classical	Pr (OBSV $H_0$ )	Empirical probability population distribution for static	Pr (error declaration on $H_0$ )	Relatively broad for single event (subjective Prob)
Bayesian	A posteriori Pr (evidence) (updates belief on $H_0$ given new data)	Empir./Subj probability exhaustive definition of causes "A Priori" Pr (causes)	Updates likelihood of the occurrence of an event	Relatively broad but difficult when many casual factors, good for event analysis
Dempster/ Shafer	Pr ( $H_0$ mult. evidence) and Pr (and	Empir./Subj. probability exhaustive (Include. disj) Pr ( $H_1$ evidence)	Updates likelihood of the occurrence of an event and level of uncertainty	Same as above
Fuzzy Set Theory	Set algebra where set elements have membership function	Subjective membership functions for all set elements	Profile of goal set elements and membership function	Decision analysis expert systems
Cluster Analysis	Sorting of observations into "natural groups" based on "similarity measure"	Parametric, subjective	Cluster elements and similarity measures	Broad but for vague category structures
Estimation Theory	"Best" state estimate for given observations (least squares)	Quantitative observations state/observ. model	State vector	Tracking, geolocation
Entropy	Computes measure of information content	Empirical or subjective probability	"Optimal" Pr	Relatively broad
Figures of Merit	Computes degree of similarity between two entities	Two attribute vectors	Numerical value of similarity	Broad
Expert Systems	Computer program to mimic human inference process	Observation data to support inferences	Declaration of inference	Broad for heuristic problems
Templates	Pattern matching technique for complex associations	Observed data records	Declaration that data supports (matches)	Situations, assessment, association

**Source:** Mona Toms and Gilbert Kuperman, "Sensor Fusion: A Human Factors Perspective," Research Report, (Wright-Patterson AFB, Ohio: Armstrong Laboratories, Air Force Systems Command, , 1991), 48.

**Glossary of Terms:**

**Pr** Probability of recognition

**H<sub>0</sub>** Null Hypothesis

**H<sub>1</sub>** Positive ID Hypothesis

**A Priori Evidence** From cause to effect, deductive reasoning, decision made before full examination

**A Posteriori Evidence** From effects to cause, inductive reasoning, determining general principles from facts

## **Appendix B**

### **Acronyms**

CDC	Center for Disease Control
DMSP	defense meteorological satellite program
ELINT	electronic intelligence
FBI	Federal Bureau of Investigation
HUMINT	human intelligence
INTERPOL	International Criminal Police Organization (ICPO)
JOPES	joint operations planning and execution system
LANDSAT	land satellite (and earth imaging satellite system)
LOGSTAT	logistics statistics
MASINT	measurements and signals intelligence
NOAA	National Oceanic and Atmospheric Administration
PPBS	planning, programming, budgeting system
SIGINT	signals intelligence
SORTS	status of resources and training system
WHO	World Health Organization



## ***Bibliography***

### **Books and Manuals**

- Gates, Bill, Nathan Myhrvold, and Peter Rinearson. *The Road Ahead*. New York: Viking Press, 1995.
- James, Maj Glenn. "Who Needs Chaos Theory." *Theater Air Campaign Studies Course Book*. Maxwell AFB, Ala.: Air Command and Staff College, 1996.
- Joint Publication 0-2, *Unified Action Armed Forces (UNAAF)*. Joint Chiefs of Staff, Washington, D.C.: United States Government Printing Office, 24 February 1995.
- Joint Publication 3-0, *Doctrine for Joint Operations*. Joint Chiefs of Staff, Washington, D.C.: United States Government Printing Office, 1 February 1995.
- Joint Publication 5-0, *Doctrine for Planning Joint Operations*. Joint Chiefs of Staff, Washington, D.C.: United States Government Printing Office, 13 April 1995.
- Negroponete, Nicholas. *Being Digital.*, New York: Alfred A. Knopf, a division of Random House, 1996.
- Petersen, John L. *The Road to 2015, Profiles of the Future*. Corte Madera, Calif.: Waite Group Press, 1994.
- USAF Scientific Advisory Board. *New World Vistas: Air and Space Power for the 21<sup>st</sup> Century*, Summary Volume. Washington, D.C.: USAF Scientific Advisory Board, 15 December 1995.

### **Articles**

- Arthur, Charles. "Holographic Movies Come in From The Cold," *New Scientist* 142, no. 1931, 25 June 1994, 21.
- Bains, Sunny. "Plasma Holograms Pack in the Memories," *New Scientist* 145, no. 1968, 11 March 1995, 22.
- Baum, David. "Assets in Wonderland," *BYTE* 20, no. 7, July 1995, 111–12.
- . "Disc Drivers," *The Economist* 335, no. 916, 27 May 1995, 74.
- Goldberg, Ron. "How Much Is That Image In the Window," *Popular Science* 246, no. 2, February 1995, 42.
- Hughes, David. "AWACS Data Fusion Under Evaluation," *Aviation Week and Space Technology* 140, no. 10, 7 March 1994, 62–63.
- Hughes, David. "MITRE, Air Force Explores Data Fusion for Joint-STARS," *Aviation Week and Space Technology* 140, no. 10, 7 March 1994, 47–48.
- Firschein, Oscar. "Defense Applications of Image Understanding," *IEEE Micro*, October 1995, 11–17.
- Langreth, Robert. "A 2-D Display is Better Than 3," *Popular Science* 244, no. 5, May 1994, 53.

- Lenat, Douglas B. "Artificial Intelligence," *Scientific American* 273, no. 3, September 1995, 62–64.
- Maes, Pattie. "Artificial Life meets Entertainment: Lifelike Autonomous Agents," *Communications of the ACM* 38, no. 11, November 1995, and "Intelligent Software," Online. Available protocol: <http://pattie.www.media.mit.edu/people/pattie>, 4 March 1996.
- Owens, Adm William A. "The Emerging System of Systems," *Proceedings*, no. 5, May 1995, 35.
- Ross, Philip E. "The Hologram Remembers," *Forbes* 54, no. 7, 26 September 1994, 170.
- Skolnick, Andrew A. "New Holographic Process Provides Noninvasive, 3-D Anatomic Views," *JAMA* 271, no. 1, 5 January 1994, 5.
- Stevens, Tim. "Holograms: More Than Pretty Pictures," *Industry Week*, 4 October 1993, 37.
- Stockton, John F. "Portable Electronic Storage Systems," *IEEE Micro* 14, no. 1, February 1994, 75.
- . "3-D CT," *Discover* 13, no. 8, August 1992, 10.
- . "Untangling the Data Traffic Jam," *USA Today* 121, no. 2577, June 1993, 8.
- Teresko, John. "Red Pepper Software—Bringing Real-time Planning and Scheduling to Manufacturing," *Industry Week* 244, no. 23, 18 December 1995, 27.
- Wayner, Peter. "Machine Learning Grows Up," *BYTE* 20, no. 8, August 1995, 63.

### **Unpublished Reports**

- Air Force Doctrine Document (AFDD-1), Unpublished draft, 1995.
- Air Force C<sup>4</sup>I Visioneering and Long Range Planning Briefing (Headquarters Air Force Communications Planning Directorate (HQ AF/SCX)), undated.
- John Boyd, "A Discourse on Winning and Losing," August 1987, Unpublished briefings and essays (Maxwell AFB, Ala.: Air University Library, Document M-U 30352-16, no. 7791).
- Fellows, Lt Col James A., LCDR Michael H. Harner, Maj Jennifer L. Pickett, and Maj Michael F. Welch. "Airlift 2025: The First with the Most," Unpublished white paper (Air Force 2025, Air University, Maxwell AFB, Ala., undated).
- Mayes, Col M. Scott, Maj Stephen G. Harris, Maj Linda Fronczak, Maj Sam McCraw, and Maj Felix A. Zambetti. "Aerospace Sanctuary in 2025," Unpublished white paper (Air Force 2025 Study, Air University, Maxwell AFB, Ala., undated).
- Negroponte, Nicholas and Dr Richard A. Bolt. "Advanced Concurrent Interface for High-Performance Multimedia Distributed C<sup>3</sup> Systems", Research Report (MIT Media Lab, March 1993).

*Rome Laboratory FY95 Command, Control, Communications, and Intelligence C<sup>3</sup>I Technology Area Plan.* Wright-Patterson AFB, Ohio: (Headquarters Air Force Materiel Command, June 1994).

Toms, Mona and Gilbert Kuperman. "Sensor Fusion: A Human Factors Perspective," Research Report, (Wright-Patterson AFB, Ohio: (Armstrong Laboratories, Air Force Systems Command, 1991).

USAF Scientific Advisory Board. *New World Vistas: Air and Space Power for the 21<sup>st</sup> Century.* Unpublished drafts, the Information Applications Volume and the Executive Summary Volume. 15 December 1995.

### **Internet Sources**

Everett, Stephanie S., Wauchope, Kenneth, and Perez, Manuel, "A Natural Language Interface for Virtual Reality Systems", Navy Research Labs, Online. Available protocol: <http://www.nrl.navy.mil>, 4 March 1996.

"Forward ...From The Sea," Online. Available protocol: <http://www.ncts.navy.mil/navpalib/policy/fromsea/fprward.txt>, 6 April 1996.

"Lace", Rome Laboratory, Online. Available protocol: <http://www.rl.af.mil:8001/Technology/summary/summary.html>, 6 April 1996.

"Longpoles in the Sea Dragon Tent," Online. Available protocol: <http://138.156.204.100/www/cwl/cwllpls.htm>, 9 April 1996.

Lucente, Dr Mark [lucente@watson.ibm.com]. "Subject re: Air Force/Air Power 2025, E-mail to Major Barbara Jefts, [bjef@max1.au.af.mil], 6 March 1996.

———. "Subject re: Air Force/Air Power 2025, E-mail to Major Barbara Jefts, [bjef@max1.au.af.mil], 21 March 1996.

———. MIT Media Labs, Online. Available protocol: <http://lucente.www.media.mit.edu/people/lucente.pubs>, 4 March 1996.

———. "Imaging Sciences and Technology", IBM Research: Visualization Spaces: Imaging Science and Technology, Online. Available protocol: <http://www.research.ibm.com/imaging>, 4 March 1996.

Maes, Dr Pattie. "A Formidable Goal," MIT Media Labs, Online. Available protocol: <http://pattie.www.media.mit.edu/people/pattie>, 11 March 1996.

"Milestones," Online. Available protocol: <http://www.nanothinc.com/NanoWorld/milestones/nwmilestones.html>, 15 April 1996.

Wauchope, Kenneth. "InterLACE," Navy Center for Applied Research in Artificial Intelligence, Online. Available protocol: <http://www.aic.nrl.navy.mil/~wauchope/interlace/interlace.html>, 4 March 1996.

## **Personal Communications**

Fleming, CWO William E. USMC, VGMR, MAG 36. Telephone interview with co-author Maj Laura J. Sampsel, 11 April 1996.

Gunsch, Major Greg H. Air Force Institute of Technology. Telephone interview with co-author Maj Barbara Jefts, 3 April 1996.

2025 Advisor's Meeting, Air University, Maxwell Air Force Base, AL, 24–26 March 1996.

## **Concepts**

“Automated and Integrated Intelligence Seamless Fusion and Correlation System.” Concept 200059, 13 December 1995.

“Battlespace Awareness Holosphere.” Concept 900417, 8 November 1995.

“C<sup>2</sup> Sandbox.” Concept 900161, 14 September 1995.

“Data Fusion.” Concept 20119, 20 December 1995.

“Electric Grid Throw Away Sensors.” Concept 900518, 27 November 1995.

“Gnat Threat Detector.” Concept 200231, 11 October 1995.

“Holographic Charged Couple Display.” Concept 900792, 12 December 1995.

“Holographic C2 Sandbox.” Concept 900161, 14 September 1995.

“Neuro-network Computer Interface.” Concept 900182, 25 September 1995.

“Neural Interfaces.” Concept 200191, 4 January 1996.

“Personnel Identification Friend or Foe (IFF).” Concept 200021, 17 November 1995.

“Real-Time War Status Board.” Concept 900667, 5 December 1995.

“Space AWACS Concept.” Concept 900678, 5 December 1995.

“Surveillance Swarm.” Concept 200023, 20 November 1995.

“Tactical Information Display Helmet.” Concept 900317, 27 October 1995.

“3-D Holographic Display.” Concept 900385, 6 November 1995.

“Universal Translator Concept.” Concept 900341, 1 November 1995.

“Voice Command Systems.” Concept 900161, 1 February 1996.

# **The Man In The Chair: Cornerstone Of Global Battlespace Dominance**



A Research Paper  
Presented To

Air Force *2025*

by

CDR Clarence E. Carter, USN  
Maj Ronald A. Grundman  
Maj Kevin G. Kersh  
Maj Cynthia L. A. Norman  
Maj Curtis O. Piontkowsky  
Maj David W. Ziegler

April 1996

## **Disclaimer**

*2025* is a study designed to comply with a directive from the chief of staff of the Air Force to examine the concepts, capabilities, and technologies the United States will require to remain the dominant air and space force in the future. Presented on 17 June 1996, this report was produced in the Department of Defense school environment of academic freedom and in the interest of advancing concepts related to national defense. The views expressed in this report are those of the authors and do not reflect the official policy or position of the United States Air Force, Department of Defense, or the United States government.

This report contains fictional representations of future situations/scenarios. Any similarities to real people or events, other than those specifically cited, are unintentional and are for purposes of illustration only.

This publication has been reviewed by security and policy review authorities, is unclassified, and is cleared for public release.

# Contents

<i>Chapter</i>		<i>Page</i>
	Disclaimer .....	ii
	Illustrations.....	v
	Tables.....	v
	Preface.....	vi
	Executive Summary .....	viii
1	Introduction.....	1
2	Required Capability.....	4
	Core Competencies: The First Step .....	4
	Global Awareness .....	4
	Information Dominance.....	5
	The Importance of Global Awareness and Information Dominance .....	5
	The Road to Required Capabilities .....	6
	A Brief Look into the Past.....	7
	The Need for System Integration and Fusion.....	7
	The Importance of the High Ground .....	8
	Where Is the United States Headed? .....	8
	What Capabilities <i>Are</i> Needed?.....	9
	Capabilities Defined.....	9
	Surveillance .....	9
	Reconnaissance.....	10
	Persistent Access .....	10
	Fusion .....	11
	Single Point Access to Relevant Information .....	11
	The Cornerstone of Global Battlespace Dominance .....	11
	The “Man in the Chair”.....	12
	A Model for 2025: MITCH .....	14
3	System Description .....	16
	The Big Picture.....	17
	The SenseNet.....	20
	The “Eyes” and “Ears” .....	20
	SenseNet Components.....	21
	Emerging Technologies.....	24
	SenseNet: Only One Piece .....	25
	The IntelSpace .....	25
	Information Domain .....	27
	Network Architecture.....	28
	Emerging Technologies.....	28
	The Human Role .....	33
	Training MITCH .....	34
	Training the Trainer .....	34
	Countering Countermeasures.....	35

<i>Chapter</i>	<i>Page</i>
Operational Analysis .....	36
4 Concept of Operations .....	39
“Push You/Pull Me” .....	40
Global “PlugIn Play” .....	41
“Right Product” .....	41
A Word on Users .....	42
Supporting Users across Any Mission and Medium.....	42
User Interfaces .....	43
MITCH at Work.....	43
5 Investigation Recommendations .....	46
Technology Considerations.....	47
Commercial Advances .....	47
Areas Requiring Military Emphasis.....	48
Cultural Considerations .....	49
Acquisition Methodology.....	49
Acquisition Management.....	50
Concept Development from Here.....	51
SenseNet Evolution.....	51
IntelSpace Development .....	52
Supporting Acquisitions.....	52
Acquisition Summary.....	53
Conclusion.....	54
<i>Appendix</i>	<i>Page</i>
A Sample Systems.....	56
B CLARK Small-Satellite Initiative Technology Areas.....	58
C MITCH Tasks.....	60
Bibliography.....	67



## *Illustrations*

<i>Figure</i>	<i>Page</i>
2-1. Shrinking Decision Cycles/OODA Loops. ....	6
2-2. Following the Global Situation.....	12
2-3. The “Man in the Chair.”.....	13
3-1. MITCH’s Role in the Decision Cycle.....	17
3-2. MITCH. ....	18
3-3. The IntelSpace.....	26
5-1. Acquisition Strategy. ....	53
C-1. 2025 Operational Analysis Structure. ....	61
C-2. Force Qualities Supporting the Awareness Mission. ....	61

## *Tables*

<i>Table</i>	<i>Page</i>
1 Analysis: The “Detect” Task.....	62
2 Analysis: The “Understand” Task.....	63
3 Analysis: The “Direct” Task.....	64

## *Preface*

In December 1994, Gen Ronald R. Fogleman, Air Force chief of staff, initiated *Air Force 2025*—a study to identify air and space power requirements 30 years in the future. To support the effort, General Fogleman tasked Air University to generate white papers that would seed the Air Staff and major air commands with new ideas and concepts for the future. Air University responded by creating more than 30 teams to focus on distinct areas of mission emphasis. This white paper embodies the research conducted by one of those teams—the team responsible for conceptualizing what “Space Surveillance and Reconnaissance Fusion” means in the year 2025.

Our vision of surveillance and reconnaissance fusion in 2025 clearly identifies an intelligence architecture with human-like characteristics. It will simultaneously sense and evaluate the earth in much the same way you remain aware of your day-to-day surroundings. This vision is so central to assimilating the paper’s underlying details that our architecture bears as its title the acronym MITCH (derived from the “Man In The CHair”). We hope this technique of personification will anchor readers to the human analogy drawn throughout the paper.

The concept and technologies behind MITCH merit further development. Feedback from top-level professionals serving as *2025* advisors and assessors strongly supports this assertion. Maj Gen Garrison Rappmund, USA, Retired, for example, believes the vision of MITCH is an essential tool for our decision makers in Washington. He believes our vision provides a framework for understanding how the stream of new information technologies can be applied. The *2025* advisors noted that MITCH stood out as one of “the nuggets” in the Air University effort. Gen Bernard Schriever, USAF, Retired, strongly concurred and recommended forwarding MITCH to the chief of staff of the Air Force as one of *2025*’s top concepts. *The message from these senior leaders is clear: the work in this paper must not be laid to rest on a dusty shelf. Let the real experts take it and run with it.*

That said, we acknowledge the assistance and guidance we were given during the course of this study. First mention must go to those who guided the efforts across the Air War and Air Command and Staff Colleges. The leadership of Col Richard Szafranski, Col (PhD) Joseph Engelbrecht, Jr., Col Michael Kozak, and their respective staffs served as catalysts to all **2025** papers. Second, reviewer comments from the Air Force's Scientific Advisory Board, **2025** advisors, and the Air Force Institute of Technology played key roles in our ability to add finishing touches to our concept. Third, this paper drew strength from work previously advanced in Air University's SPACECAST 2020 study and the Scientific Advisory Board's recently completed *New World Vistas: Air and Space Power for the 21st Century*. These studies offered us a point of departure from which to introduce the Air Force's next leap toward leveraging the "Information Age." Finally, we acknowledge the efforts of Lt Col (PhD) T. S. Kelso, CDR Homer Coffman, and Ms Marlene Barger. These individuals worked tirelessly to make it easier for students to meet both **2025** and Air Command and Staff College requirements.

## *Executive Summary*

*A general should possess a perfect knowledge of where he is carrying on a war.*

—Niccolo di Bernardo Machiavelli

Knowledge of the battlefield has always been a matter of life or death for the warrior. By 2025, the importance of this concept will be magnified—growing weapon lethality and ever-tightening decision cycles will demand near-real-time and continuous battlefield awareness. In short, possessing knowledge will not simply determine who will live but who will win. This paper provides a vision for the future, *describing a concept and a system that provides the United States with the cornerstone for unrivaled comprehension of the 2025 battlespace by giving the right decision makers the right information at the right time.*

The proposed system is both evolutionary and revolutionary. It is evolutionary in that it capitalizes on emerging satellite technologies to more fully exploit the “high ground” of space for surveillance and reconnaissance; continuous global awareness is the result. It is revolutionary in what happens as space collectors pipe their data of the world to a terrestrial “brain” that fuses it with data from all other sources. This “brain” leaps beyond data, creating what is really required by decision makers—information, and if possible, knowledge. Logical patterns are established. Additional sensor collection is autonomously ordered to improve information quality. Conclusions are drawn. In effect, the system functions much as the human does—subconsciously aware of the general environment, focused on stimuli of importance, and continuously making sense of it all. That is the revolution, and information dominance flows from it.

In addition to developing a vision, this paper proposes the capabilities required to bring that vision into reality—truly *global* surveillance, responsive high-resolution reconnaissance, around-the-clock access, fusion of data into information, and answers for decision makers at the *right place and time*. These capabilities are brought together in a human analogy, the “Man in the Chair.” This analogy provides a conceptual understanding for a new system that will serve as the cornerstone of global battlespace

dominance. The paper identifies the specific technologies required to build such a system. What emerges is a powerful mix of small satellite, high-capacity communication, processing, storage, and artificial intelligence technologies. The system is called MITCH, “Man In The CHair.”

On their own, these new technologies are not enough to “bring MITCH to life.” How decision makers interact with the system is just as important as the system itself. Recognizing this, the authors discuss the concept of operations. This concept exploits links across every medium to give users and decision makers the product they ask for. This concept of operations also allows MITCH to alert users with information that deserves immediate attention. Both approaches are captured in vignettes that demonstrate MITCH’s usefulness in both combat and peacetime operations.

The road MITCH must travel to 2025 is a difficult one. The last chapter highlights three critical aspects of that road. First, commercial initiatives must be complemented by government developments in selected areas. Second, users and decision makers must come to trust MITCH as an integral part of their decision processes. Third, an acquisition strategy must be pursued that embraces these ideas. Success in these three areas will underpin the ability to bring MITCH on line by 2025.

MITCH. The “Man In The CHair.” A system designed, acquired, and operated as the cornerstone for unrivaled comprehension of the global battlespace. In the dynamic and uncertain world of 2025, the security of the United States of America rests on the aggressive pursuit of the vision MITCH offers.

# Chapter 1

## Introduction

*The doctrine of war is to follow the enemy situation in order to decide in battle.*

—Sun Tzu  
*The Art of War*

The American colonel searched the terrain slipping under the wings of his multirole fighter. It was rugged country, pocked here and there with scars of war. The day's mission was simple: seek out and destroy a small Iranian armored force believed to be infiltrating the Coalition's rear area. "*Believed* to be infiltrating." He grimaced at the thought, acknowledging the uncertainty plaguing the American's first high-intensity combat since the Gulf War in 1991. The Iranians had succeeded in strategically surprising the world with their occupation of the oil-rich Persian Gulf region in 2013. A year later, their fluid, small-unit operations continued to hamper the coalition's efforts to free the region. The colonel squinted. He knew the coalition would eventually prevail, but regretted the losses slowly mounting with each passing day. His eyes cross checked his wingman and then headed back to the ground. "It didn't have to be like this," he reflected. Desert Storm, a conflict where he saw 23 combat sorties as a brand new captain, "footstomped" the critical importance of knowing where your enemy was—in time to do something about it. Everybody had seen it, but the point was dulled somewhere in the drawdowns, budgets, and forecasts of low-tech wars. The military application of commercial developments could have been so much more. The colonel glanced at his fuel gauge. Bingo—time to head home. In the end, he would never know that the infiltrating armored force had diverted away from the area he so meticulously combed. That was information still adrift in the US intelligence community's sea of data. He would soon discover, however, something completely missed by US sources. The Iranians had deployed advanced SAM batteries into the region. In fact, they were the last thing he would ever see.<sup>1</sup>

Reduced to its simplest elements, war is about killing or being killed. It is about destroying or being destroyed. In Sun Tzu's wisdom, war's endgame is deciding battle on terms favorable to friendly forces. But if "everything in war is simple," then why does Clausewitz go on to say that "the simplest thing is difficult?"<sup>2</sup> The above vignette of an American warrior in the future suggests an answer. To kill or destroy, one must know where the targets are. To survive, one must know where the threats are. In short, one must

follow the enemy situation—historically, one of war’s and the world’s most difficult challenges. This paper addresses that challenge and how it can be met in the year 2025.

It seems certain that following the enemy situation will be more difficult to master in 2025. Martin van Creveld predicts the world will be embroiled in numerous regional, low-intensity conflicts.<sup>3</sup> Perhaps China, as suggested in the *2025 King Kahn* alternate future, will challenge the United States (US) as the world’s superpower.<sup>4</sup> Whatever the situation, it will involve American national interests. Supporting this, Alvin and Heidi Toffler note that the number of agreements and treaties between the US and other countries is growing exponentially, reflecting an “exploding” American interdependency around the world.<sup>5</sup> In this environment, almost every location on the globe becomes a potential battlespace—economic, political, or military. Numerous nations, as well as many organizations, become potential adversaries.

How will the US tell who its enemies are? And for that matter, how will the US tell who its friends are? What events will affect the interests of the country? Which will not? In 2025, Sun Tzu’s challenge takes on a new perspective. In order to decide in battle—no matter what form it may take—the US must be able to *follow the situation of the world*—the global battlespace. The survival and continued success of the country may well depend on it.

Following this global situation, this global battlespace will be not be easy. It demands that tough questions be asked and answered. What are the basic abilities, the core competencies, the US *must* possess? Next, what capabilities are required to bring these core competencies to reality? Only with a detailed and thorough understanding of these issues will the US possess the foundation needed to meet the challenge of 2025—to *follow the situation of the world*.

This paper takes precisely the approach suggested above. It *describes a concept and a system called the “Man In The CHair,” or MITCH, that provides the United States with a cornerstone for unrivaled comprehension of the 2025 battlespace by giving the right decision makers, the right information, at the right time.*<sup>6</sup> In following this thesis, it should be clearly understood that MITCH’s purpose is not to decide on courses of action—that is for human decision makers or automated targeting systems to do. Instead, MITCH gives those decision makers information about the global situation that is unmatched in quality and

availability. MITCH is the answer to Sun Tzu's age-old challenge "to follow the enemy situation in order to decide in battle."<sup>7</sup>

### Notes

<sup>1</sup> This is a plausible scenario based on background research by the **2025** Alternate Futures team, part of an Air Force chief of staff directed study conducted at Air University during the 1996 academic year. This study hypothesized a conflict with Iran by 2015.

<sup>2</sup> Carl von Clausewitz, *On War*, ed. and trans. Michael Howard and Peter Paret (Princeton, N. J.: Princeton University Press, 1976), 119.

<sup>3</sup> Martin van Creveld, *The Transformation of War* (New York: The Free Press, 1991), 194.

<sup>4</sup> One possible alternative for the world in 2025 was a future scenario titled *King Kahn*. This plausible scenario was developed by the **2025** Alternate Futures team. It is one of six scenarios developed by the team.

<sup>5</sup> Alvin and Heidi Toffler, *War and Anti-War* (New York: Warner Books Inc., 1993), 293.

<sup>6</sup> The concept and the system presented in this paper use the term man in a generic sense. This was done to provide the reader with a clear and distinctive vision that would bind together the various concepts and technologies presented. Using the concept of the "Man in the Chair," and the system name derived from it, MITCH, allows a personification of the system which is needed to clearly convey the authors' concepts.

<sup>7</sup> Sun Tzu, *The Art of War*, ed. and trans. Samuel B. Griffith (London: Oxford University Press, 1963), 140.



## Chapter 2

### Required Capability

#### Core Competencies: The First Step

Following the global situation and using it to dominate the global battlespace require two things—the ability to see what is happening at all times and the ability to get the right information to the right decision maker at the right time. It requires the core competencies of global awareness and information dominance. This first step must begin with a clear understanding of what these two competencies are—and what they are not—and examine why they will be important in 2025.

#### Global Awareness

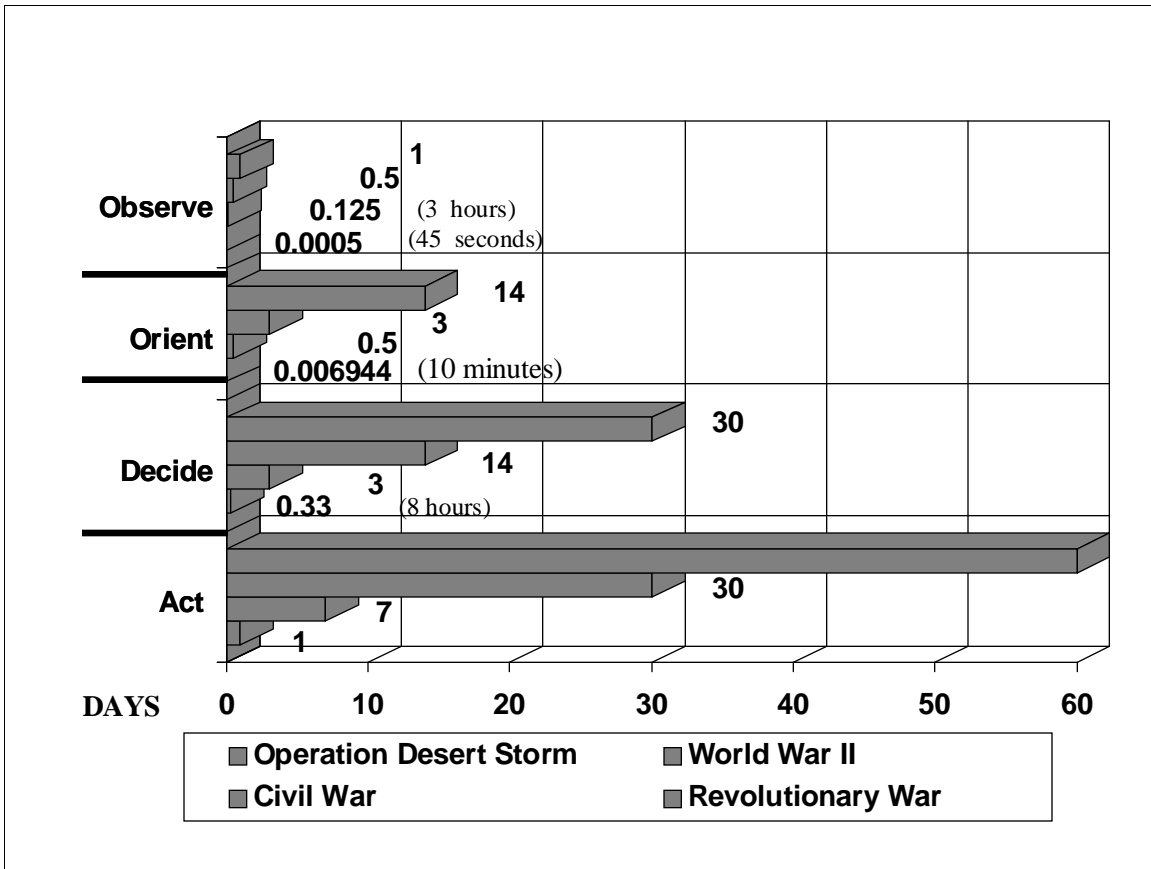
Global awareness is the ability to reliably, accurately, and continuously collect information on the situation, enemy or friendly, anywhere in the world. It is the mechanism that pinpoints targets and threats. Global awareness is a matter of degree and not an absolute—*no approach to it will ever achieve total omnipresence*. Instead, global awareness implies the ability to pull as much useful information from a region as the laws of physics permit. The degree to which future systems succeed in that endeavor will be determined, in large part, by the sensors and intelligence techniques of that day.

## **Information Dominance**

This second core competency is the ability to intelligently route the right information to the right decision maker at the right time. This mechanism allows the decision maker to decide in battle. Again, success in this competency is relative and not absolute. *No approach will ever permit omniscience.* Instead, information dominance occurs when US decision makers possess the information required to make decisions faster and better than any enemy.

## **The Importance of Global Awareness and Information Dominance**

Certain trends leading to the year 2025 make global awareness and information dominance critical to successfully following the global situation. First, rapid technological growth will almost certainly threaten United States (US) military forces with increasingly capable opponents. These opponents will possess weapons that are more lethal. They will develop surveillance and targeting architectures that make them better at finding and targeting American forces. In effect, combat will become less forgiving to the force fired upon first. Where the penalty of previous wars has been measured in terms of men lost, the penalty in 2025 could be measured in units lost. The second trend driving global awareness and information dominance is the shrinking time available to decision makers as they strive to act first. Said another way, John Boyd's proposed "OODA loop," (Observe, Orient, Decide, and Act) is ever tightening.<sup>1</sup> Figure 2-1 shows how the OODA loop of American forces has dramatically collapsed since the Revolutionary War.



**Source:** Data from ACSC Technology Division and War/Theater Level Studies Department, *The O-O-D-A Loop Toolbook*, Maxwell AFB, Ala., 1995.

**Figure 2-1. Shrinking Decision Cycles/OODA Loops.**

Extrapolating this historical characteristic out to 2025 leads one to anticipate a near-real-time decision cycle where observations are received in near real time; orientation is continuous; decisions are arrived at immediately; and actions take place in seconds. Indeed, by 2025, the OODA loop may well be an *OODA point*—an environment for which today’s military is not equipped. So what is to be done by 2025? What capabilities ensure the global awareness and information dominance required to deal with the future’s lethality and real-time tempo? Answering these questions requires a look at the past.

### The Road to Required Capabilities

The basic concepts underlying global awareness and information dominance are not new. For centuries, decision makers and military forces have sought victory over their adversaries by gaining a better “view” of the situation and obtaining better information from which to base decisions; this will not change in

the future. In that regard, this section briefly looks at past, present, and near-term efforts to provide the right intelligence information to the right decision makers. Within that framework, four specific areas are addressed including (1) the evaluation of Gulf War information systems by senior decision makers, (2) the importance of system integration and fusion of data, (3) the value of space as the new high ground, and (4) how advances in systems since the Gulf War continue to fall short of what is required for the future.

### **A Brief Look into the Past**

The various services have sought to develop new and better information systems—each seeking to provide the right product, to the right decision maker, at the right time. The Gulf War was the first real test of what the military had spent many years and dollars to develop. Maj Gen James Clapper, USAF, former director, Defense Intelligence Agency and Air Force Intelligence, stated that the Gulf War “served as a crucible for systems that collect, analyze, fuse, and disseminate intelligence.”<sup>2</sup> The results of that trial were captured in the testimony of Gen H. Norman Schwarzkopf, Commander in Chief Central Command, before the Senate and House Armed Services Committees. In that testimony, he conveyed he did not always have the information he needed and recommended the intelligence community immediately begin developing systems “capable of delivering a real-time product to [the] theater commander when he requests [it].”<sup>3</sup>

### **The Need for System Integration and Fusion**

General Schwarzkopf’s remarks prompt a closer examination of the war often praised as a prime example of a successful intelligence operation.<sup>4</sup> What emerges is evidence that the nation’s intelligence systems lacked effective integration. War fighters were forced to use a number of different intelligence-gathering systems, each providing a separate image or description of the battlespace. As a result, Desert Storm operations required extensive human effort to merge the different system products. This requirement created information overload and often denied decision makers the intelligence information they needed at key junctures. A critical missing element was “fusion”—the combining of “multisource data into intelligence necessary for decision making” without degrading timeliness or creating information overload.<sup>5</sup> Without question, detailed information was available, but it was not in the right hands at the right time—constraining

information dominance. To complicate matters, limited numbers of sensors, both spaceborne and airborne, provided only periodic, incomplete coverage of the battlespace—preventing global awareness.

### **The Importance of the High Ground**

Notwithstanding the shortcomings just discussed, Operation Desert Storm has been christened the “first space war” and did provide hints of future required capabilities.<sup>6</sup> Indeed, the Gulf War reiterated the timeless advantage of the high ground in “viewing” the enemy. According to Sir Peter Anson and Dennis Cummings in an article published shortly after the war, “military experts agree that satellites helped to win the political battle, sustained command and control, shortened the war, and saved lives.”<sup>7</sup> Space became the new “high ground” and took its place as the foundation of global awareness. This is supported by the words of Gen Merrill McPeak, then USAF chief of staff: “Space is fast becoming the center piece of our strategic leverage. I’m convinced that tomorrow we will judge a nation’s power by its relative position in space.”<sup>8</sup> American space systems confirmed how the words of Tao Te Ching still apply today:

Distant ridges, far away clouds . . . All events come from a distance. With a high vantage point, foretelling the future is elementary.<sup>9</sup>

### **Where Is the United States Headed?**

American attempts to take advantage of the new high ground and provide the right information to the right decision maker seem nothing short of revolutionary. On the surface, it would seem every aspect of intelligence gathering, processing, and dissemination has been anticipated and achieved. Appendix A provides a short description of eight current and future systems aimed at tying together various surveillance, reconnaissance, intelligence, and information assets. Yes, access to and quality of information for decision makers and war fighters will improve, but it is not enough for the future. The systems listed, along with others that are envisioned, still present two major problems. First, the national command authority, combatant commanders, and weapon system operators will still be inundated by information from multiple systems providing nonfused products. It seems the United States (US) is slow to grasp the limitations of overlaying one category of information from one system over another category of information from another.<sup>10</sup>

Second, the “view” of the world will still not be continuous. Both problems must be addressed in the future. American decision makers must be able to make the right decisions and do so in seconds—in essence, “points in time.” What exists now and what is on the drawing board for the future will not provide the global awareness and information dominance needed to follow the global situation and dominate in battle.

### **What Capabilities *Are* Needed?**

The right product to the right decision maker at the right time. Decisions in points in time. A global battlespace. Friends? Adversaries? No one can predict with certainty what the future will hold for the US. But whatever the future brings, the message is clear. The US must be able to follow the situation of the world—the global battlespace. This ability requires these critical capabilities:

- surveillance to “paint” a global picture with multiple sensor types;
- reconnaissance to provide high-resolution “zoom” in areas of interest;
- persistent, continuous access to the entire globe;
- fusion—the combination of data from various sources into intelligence information needed for decision making—without degrading timeliness or creating information overload; and
- single point access to required/relevant information for a multitude of users.

### **Capabilities Defined**

Surveillance. Reconnaissance. Persistent global access. Fusion of collected data. Single-point access for users. What do these terms and concepts really mean relative to 2025?

#### **Surveillance**

Imagine 2025. The rate at which international “hot spots” emerge accelerates with the world’s shift to greater interdependency. Mainstream weapons of mass destruction, rapidly deploying forces, and the ever-valuable information edge raise the risks of conflict. To survive, the US must instantly identify all hot spots and quickly amass a wide spectrum of relevant information. In other words, Americans must possess global surveillance through multiple sources.

Global surveillance requires only awareness, not complete knowledge. Drawing back to a definition of surveillance, it is the ability to detect important changes in situations that would remain uninteresting if the status quo were to persist. Since changes across the globe come in many forms, different collection sources must work together to maintain this global awareness. Candidate sources include tried-and-true sensors found today. They include humans in the field. In 2025, they will no doubt include sensors yet only imagined. The point is, where change signatures are left for sensors, surveillance assets must continually monitor those signatures—everywhere.

### **Reconnaissance**

Simply detecting change in the global environment is not enough—today or in 2025. Instead, when change is noted by surveillance assets, decision makers want to know more. Reconnaissance focuses high-resolution collection assets to provide decision makers with a “zoom” look at the region of interest. Like surveillance, reconnaissance is strengthened when different collection sources work together to “paint” a complete “picture” of the situation at hand. In addition, since surveillance may note changes anywhere in the world, reconnaissance assets must also have global access.

### **Persistent Access**

The first two required capabilities mandate that multisource surveillance and reconnaissance systems have global access to any part of the world. The next required capability mandates global access to any region at *all times*. In short, surveillance and reconnaissance must be persistent. A large part of this persistence stems from the mix of collection assets employed. An all-weather, day-night mix is more persistent than a daylight only system. A “behind closed doors” capability (e.g., human intelligence) strengthens persistence further. Absolute persistence is only achieved, of course, if the proper mix of assets has continuous line-of-sight access to the targeted points of interest.

For many surveillance and reconnaissance collectors, line of sight can be assured by the “high ground”—an age-old pursuit of the warrior. Medieval times found scouts climbing the highest hill to observe enemy positions. In colonial times, lookouts, perched atop the masts of their man of wars, sought to locate

the opposing navies. In more modern times, aerial observers flew small aircraft behind enemy lines to identify vital targets. In all these cases, the “high ground” multiplied the effectiveness of combat operations. This remains true today and will remain true in 2025. Any system designed to continually “follow the enemy’s situation”<sup>11</sup> will exploit the “high ground” of space.

## **Fusion**

Fusion is the act of bringing together the wealth of data from persistent surveillance and reconnaissance. As defined earlier, fusion is the combining of “multisource data into intelligence necessary for decision making” without degrading timeliness or creating information overload.<sup>12</sup> The core concept of fusion is the combination of *multisource data* into an *integrated information product*. This means that a single, integrated, analyzed “intelligence picture” is constructed from data supplied by various sensors and other sources. The quality and accuracy of the intelligence picture synergistically improves as data from additional sources is included.

Another important concept in the definition is that fusion must occur without degrading timeliness or creating information overload. In other words, when a user needs intelligence information, it is there—in a form that is clear, concise, and not overwhelming.

## **Single Point Access to Relevant Information**

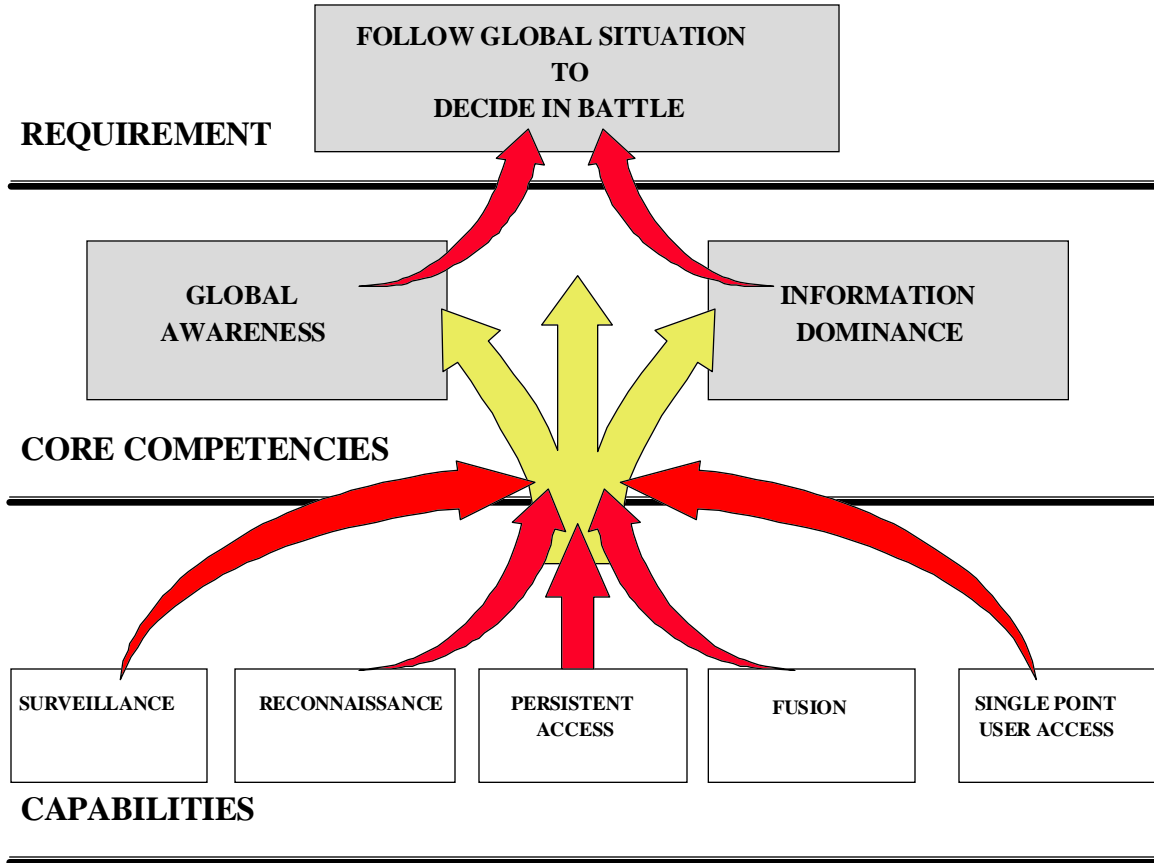
Very simply, all users must get the information they need from a single system. This is true whether the decision maker is at the strategic, operational, or tactical level.

## **The Cornerstone of Global Battlespace Dominance**

The five capabilities described above form the cornerstone, an indispensable and fundamental part, of the ability of the US to follow the global situation in order to decide in battle (fig. 2-2). They provide the US with the ability to collect, analyze, and fuse data into intelligence information under *diverse conditions*,



doing so *everywhere, continuously*. They provide the users with the information they need—anywhere and anytime.



Source: Clipart from Microsoft Clipart Gallery © 1995 with courtesy from Microsoft.

Figure 2-2. Following the Global Situation.

### The “Man in the Chair”

Is there any system existing today that exhibits these capabilities required for the future? Yes! The human system—the senses, the nervous system, and the brain. Continually collecting, analyzing, and fusing data, it is aware of its surroundings and has the ability to focus on important events. It delivers the necessary information when needed for accurate decision making.

Let’s look at an example—the “Man in the Chair” (fig. 2-3). Sitting in his study, a man is reading today’s newspaper—his eyes and mind focused on the words at hand. At the same time, all his senses are

maintaining a continuous “picture” of all that is occurring in his surroundings. Without conscious effort, the man’s brain receives information through his nervous system from his various senses, evaluates it for importance, stores it away for possible use, and determines if further action is required. Though “aware” of his surroundings, the man is not distracted by routine events—the conversation in the hallway, the smell of fresh cut grass coming through an open window, or the noise from the yardman mowing the grass. Suddenly, a door is slammed. The man’s brain immediately brings his senses to focus on what has occurred. His ears tell him that a loud bang came from somewhere behind him.



**Source:** Clipart from Microsoft Clipart Gallery © 1995 with courtesy from Microsoft and CorelDraw! © 1994 with courtesy of Totem Graphics Inc.

**Figure 2-3. The “Man in the Chair.”**

Several actions might now occur depending on what the man’s brain has stored away. Recalling that everyone else had left the house five minutes before; the door to the study had been open; a strong wind was blowing through an open window in the other room; and having heard the sound of the study door slamming

on another occasion; the man might quickly and accurately conclude that the wind had blown the door closed. In this instance, the man's brain may not have brought other senses into play.

But what if the man does not have all this information stored away? In this case, the sound triggers the brain to focus its other senses on the event. First, the man turns so that he can see the area behind him. He notices the study door is now closed. Wondering how it was closed, he gets up, opens the door, and looks to see what is on the other side, "zooming" in to get a clearer picture of what has happened. He notices a strong wind blowing through an open window and thinks that maybe the wind has blown the door shut. Just to be sure he calls out "anybody there?" and walks through the rest of the house to see if someone is there.

As he moves through the house, all the man's senses are at a heightened state of alert and his brain is searching other stored information to anticipate what might happen next. All the while, the man's brain is collecting and fusing information from his senses to aid his decision making and is doing so almost instantaneously with little apparent effort.

#### **A Model for 2025: MITCH**

How does this analogy apply to a system that can meet the demanding challenges in 2025? Only an integrated system, one similar to the "Man in the Chair," one that maintains its own awareness of the global situation, can meet them.

The Air Force Scientific Advisory Board has identified this same major focus for the future: "to know at all times the relevant global military situation given the existing political and economic conditions and the state of military conflict." They believe "such awareness should be in near real time (in time enough to understand and act) and with near perfect knowledge (knowledge good enough to make good decisions in the time available to decide and act)."<sup>13</sup> This is the foundation for global awareness and information dominance. This is the "Man in the Chair"—MITCH.

## Notes

<sup>1</sup> John R. Boyd, "A Discourse on Winning and Losing" (Paper presented at Air University for CSAF's 2025 project, Maxwell AFB, Ala., 27 September 1995).

<sup>2</sup> James R. Clapper, Jr., "Desert War: Crucible for Intelligence Systems," in *The First Information War*, contributing ed. Alan D. Campen (Fairfax, Va.: AFCEA International Press, 1992), 81.

<sup>3</sup> Harry E. Soyster, "Extending Real-Time Intelligence to Theater Level," in *The First Information War*, contributing ed. Alan D. Campen (Fairfax, Va.: AFCEA International Press, 1992), 61-62.

<sup>4</sup> The United States is credited with devastating Iraq's formidable military machine by exploiting knowledge and leveraging information. This is asserted in Alan D. Campen, ed., *The First Information War* (Fairfax, Va.: AFCEA International Press, 1992), ix.

<sup>5</sup> AFP 200-18, *Target Intelligence Handbook Unclassified Targeting Principles*, vol. 1, 1 October 1990, 11.

<sup>6</sup> The "first space war" designation was a result of the extensive use of space-based assets to carry out communications, navigation, surveillance, and meteorological projections.

<sup>7</sup> Sir Peter Anson and Dennis Cummings, "The First Space War: The Contribution of Satellites to the Gulf War," in *The First Information War*, contributing ed. Alan D. Campen (Fairfax, Va.: AFCEA International Press, 1992), 121.

<sup>8</sup> James R. Asker, "Space, Key to U.S. Defense," *Aviation Week & Space Technology* 138, no. 18 (3 May 1993): 57.

<sup>9</sup> John L. Petersen, *The Road to 2015: Profiles of the future* (Corte Madera, Calif.: Waite Group Press, 1994), 287.

<sup>10</sup> Maj Lori Colodney, "Getting Command and Control System Back into the Fight on the Digitized Battlefield," Fort Leavenworth, Kans., 17 December 1994, 22.

<sup>11</sup> Sun Tzu, *The Art of War*, ed. and trans. Samuel B. Griffith (London: Oxford University Press, 1963), 140.

<sup>12</sup> AFP 200-18, 11.

<sup>13</sup> USAF Scientific Advisory Board, *New World Vistas: Air and Space Power for the 21<sup>st</sup> Century*, summary volume (Washington, D.C.: USAF Scientific Advisory Board, 15 December 1995), 57.

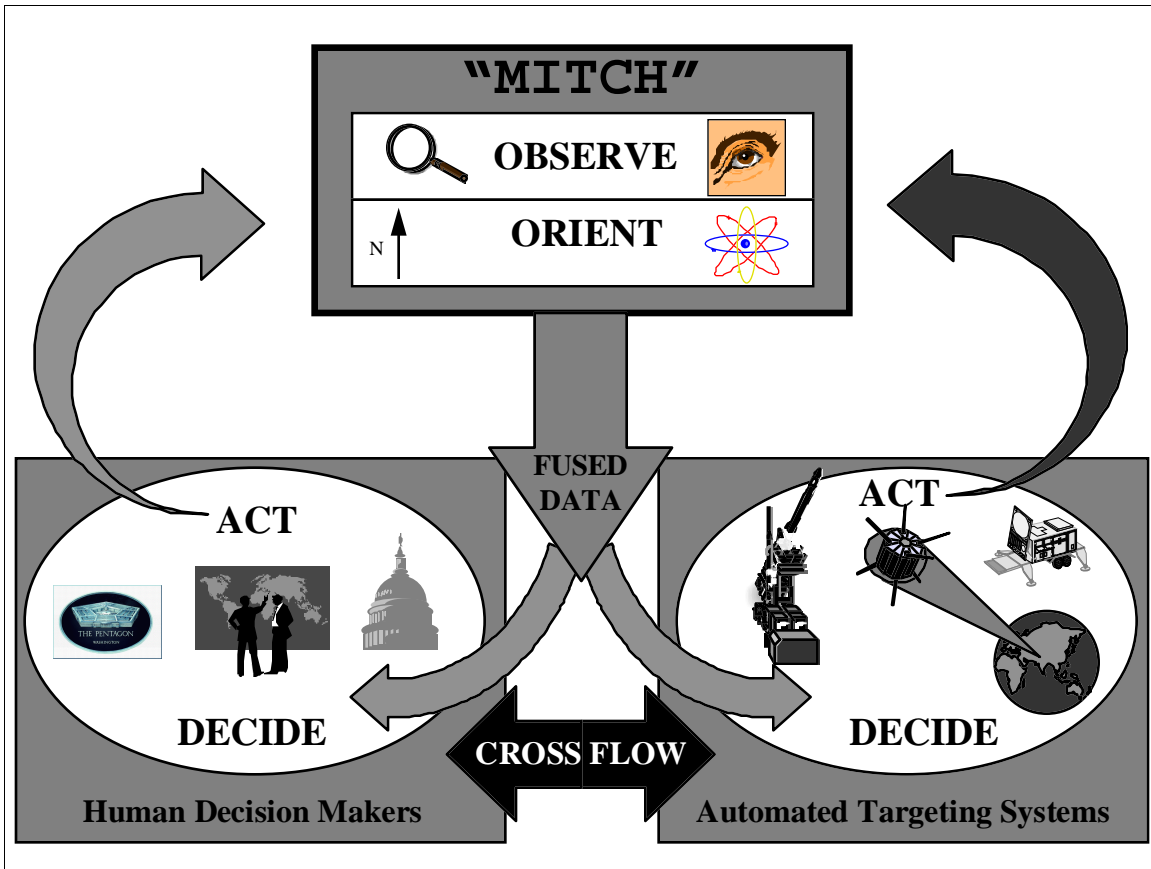
## Chapter 3

### System Description

The essence of the “Man in the Chair” is captured in a system called MITCH. With 2025 technology, MITCH offers the required capabilities of persistent global surveillance, responsive “zoom” of high-resolution reconnaissance assets, and intelligent fusion of data. It is the conceptual vision for providing the right product, in the right place, at the right time.

This chapter begins with a quick tour of MITCH as a system. What are the principle elements of the system? How do the elements fit together? How do they work together? With the “big picture” established, each subsystem will be reviewed in greater detail, including a look at the emerging technologies required to make the concept a reality. This discussion of hardware, software, and networks will be followed by a discussion of the role humans play in MITCH’s training and development. Next, the chapter identifies MITCH’s key vulnerabilities and considers friendly countermeasures to protect them. Finally, the last paragraph introduces the Air Force Institute of Technology’s operational analysis of the concepts presented in 2025 white papers.

Before continuing, it is important to note that end users, either human or automated, and specific user hardware interfaces are not considered part of MITCH. Instead, MITCH’s role is to create information and bring it to the point where users and their hardware can plug in and retrieve it. In other words, MITCH performs the observe and orient phases of the Observe, Orient, Decide, and Act (OODA) loop and leaves the decision and action phases to the human or automated decision maker (fig. 3-1). This system distinction emphasizes MITCH’s collection and information processing aspects. At the same time, it recognizes a tremendous range of users and the way they will use information.

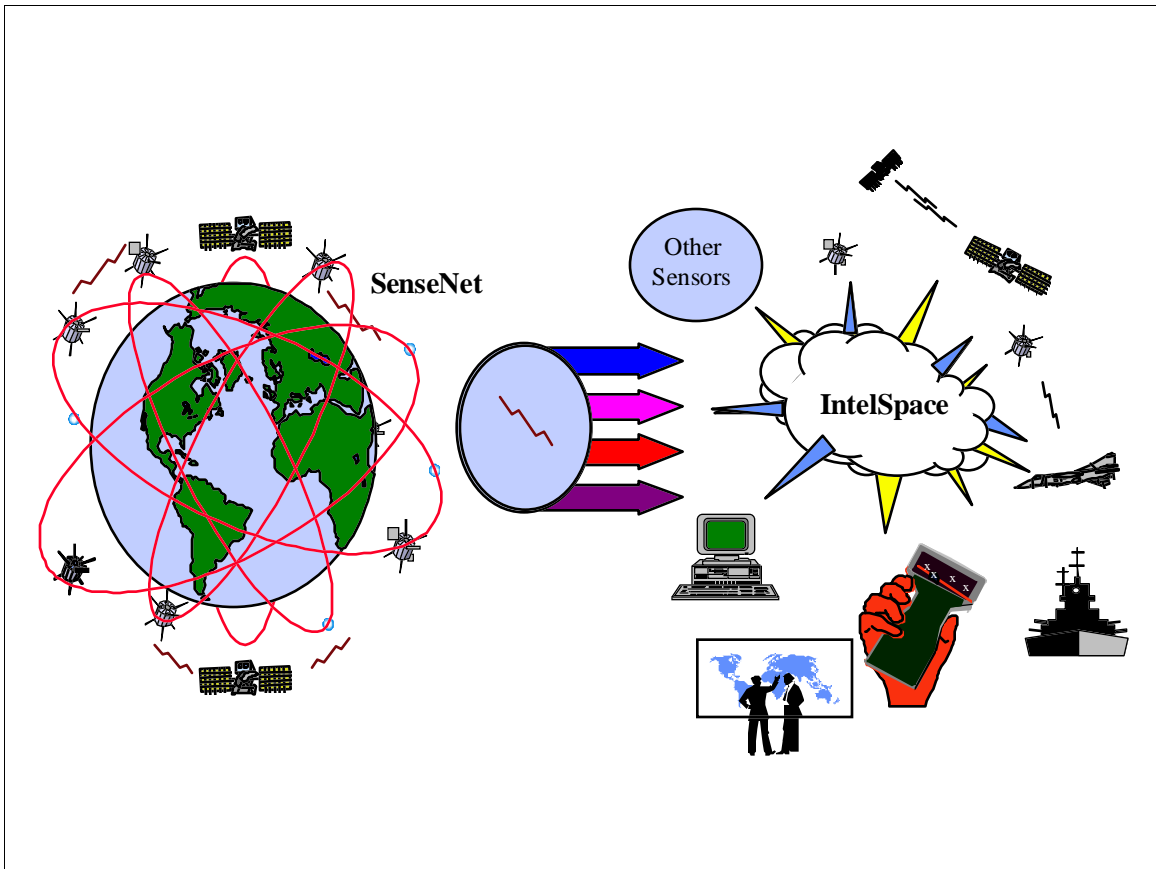


Source: Clipart from Microsoft Clipart Gallery © 1995 with courtesy from Microsoft.

**Figure 3-1. MITCH's Role in the Decision Cycle.**

### The Big Picture

Think back to the analogy of the “Man in the Chair.” In the simplest sense, two very basic processes are taking place. First, the man is collecting data on his environment. He sees, hears, touches, and smells. Second, the man is evaluating the data he collects. He correlates and responds to what his senses indicate. The two principle subsystems of MITCH—the SenseNet and IntelSpace—are built around these same two processes. Figure 3-2 introduces the conceptual illustration of MITCH and its components.



Source: Clipart from Microsoft Clipart Gallery © 1995 with courtesy from Microsoft.

**Figure 3-2. MITCH.**

The SenseNet is figuratively the “eyes and ears” of MITCH and consists of a constellation of sensor satellites (SENSAT) working continuously to provide persistent global surveillance, responsive high-resolution reconnaissance, and the first steps in data fusion. The SENSAT constellation hosts perhaps hundreds of SENSATs, each carrying one of many sensor types. This swarm of small or even microsattellites guarantees that a variety of sensor types can access any part of the globe simultaneously. The result is a richer “painting” of the global situation, made possible by the fusion of many different sensor “brushes.”

Unlike today, where virtually all processing of space data is performed on the ground, the SenseNet will develop and maintain its global picture *on-orbit*. This approach is realistic for the 2025 time frame. Advances in microprocessing and storage capacity will permit SENSATs with revolutionary onboard capabilities. Each SENSAT will store data from past orbits and share that data with other like-sensored SENSATs through high-capacity communication links. As a result, each group of like-sensored SENSATs will build a comprehensive view of the world from that sensor-type—photographic imagery for example.

The SenseNet will then test all subsequent collections for changes. Changes are downlinked to MITCH's second principle subsystem—the IntelSpace.

The IntelSpace is MITCH's "brain" and "nervous system" and is best thought of in terms of an *information domain* and a *network architecture*. Both of these components are made up of mass storage systems, high-capacity communications, high-speed processors, user agents, and artificial intelligence.

As an information domain, the IntelSpace stands as a reservoir of knowledge. It fuses SenseNet data with inputs from other collection systems to create information and, in some cases, knowledge. For example, assume the SenseNet downlinked both visual and thermal data of a single strategic bomber. Optically, the bomber is sighted on a runway and, thermally, the engines are hot. When fused together, this *data* is now *information*—the bomber is active on the runway.

What then constitutes *knowledge*? Further fusion to permit interpretation of intent. If the IntelSpace noted from human intelligence (HUMINT) that all of the opponent's bombers were similarly configured and Navy signal intelligence ships showed the opponent's command and control structure active, it might conclude that a strike was imminent—a conclusion that would be forwarded to interested users. All of this means that the IntelSpace will recognize global patterns and learn through intelligent correlation of data. MITCH will put "two and two together"—often without human intervention.

In the final analysis, the ability to automatically fuse data and recognize patterns, in seemingly unrelated events, is the heart of what MITCH offers. Without this revolution in information processing, future users would drown in sensor streams pouring in from the SenseNet and other sources. One senior department of defense policymaker's current observation of joint task force (JTF) commanders would remain typical. This policymaker, speaking to Air Command and Staff College under the promise of nonattribution, stated JTF commanders are often forced to operate several different computer systems to ensure they have access to all the information they need. In one case, a JTF commander had seven different systems on his desk.

In addition to offering intelligent, semiautonomous fusion of all-source data, the IntelSpace also serves as a network architecture. In this role, the IntelSpace tasks the SenseNet and serves as the "highway" to get the right data, information, and knowledge to the right user, at the right time.

The IntelSpace autonomously tasks the SenseNet to support conclusions or respond to user queries. In the previous scenario, for example, a lone enemy bomber on the runway might prompt the IntelSpace to direct



immediate high-resolution reconnaissance collection against all runways. This direction would come in the form of collection instructions to the specific SENSATs appropriate to the problem. The IntelSpace knows where other runways are located, knows what sensor-types are applicable, and recognizes a “snap shot” of all runways is valuable information. In its second role—that of a highway—the IntelSpace is simply the conduit through which every user interfaces. Just like today’s Internet, users will tap in through a myriad of platforms and access information spread around global sites. In 2025, however, the “surfing” is transparent to the user.

Having completed a quick tour of MITCH as a system, it is time to examine the SenseNet and IntelSpace subsystems in greater detail.

## **The SenseNet**

### **The “Eyes” and “Ears”**

As introduced earlier, the SenseNet is a constellation of small sensor satellites, or SENSATs, that serve as MITCH’s “eyes” and “ears.” Each SENSAT bears one of the many sensor types present in the total system (e.g., infrared [IR], radar, communications intelligence [COMINT], etc.). As a system, literally hundreds of SENSATs are carefully placed in complementary orbits that afford multisensor access to any spot on the globe, all the time. Today’s global positioning system (GPS) constellation is a working example of this concept. This constellation of 24 satellites ensures at least four GPS satellites are continuously in view of any user location.

Whereas the GPS provides navigation data, SENSATs will provide continuous global *surveillance* at medium resolution and focused *reconnaissance* at high resolution. Each SENSAT will collect data as appropriate to its sensor type, improving the data’s signal quality, removing redundant information, and finally, sharing that data across the SenseNet via a robust and redundant laser communication network. What emerges is a global “picture” of the world “painted” with different but complementary sensors. Each SENSAT will store an onboard “picture” of the world from its respective sensor type. Subsequent collections will be combed for changes. Only changes detected from the existing global “picture” will be

downlinked to the terrestrial IntelSpace. This concept greatly reduces routine data link usage and ensures capacity is available for surges and special tasking like “direct downlink” missions.

Typically, the surveillance SENSATs will be the first to detect change. When this happens, the IntelSpace may task the reconnaissance SENSATs over the region to collect high-resolution data. These high-resolution products can be essential to object recognition, submeter geopositioning, and some “fused” products. Stereo imagery is one example of the latter. Using raw SenseNet data generated by the simultaneous collection of a single location from two or more different angles, the IntelSpace can produce three-dimensional images of the scene.

### **SenseNet Components**

The SenseNet architecture is broken out into three components: sensors, satellites, and the satellite constellation. These components work together to collect and communicate data to the ground.

**Sensors.** What are the *right* sensors? “Leveraging the Infosphere: Surveillance and Reconnaissance in 2020” offers a long list of candidates from multispectral imagers to radio signal interceptor systems to olfactory sensors.<sup>1</sup> Advances in technologies portend exciting advances in what phenomena can be observed and the detail to which they can be observed. The particulars of these sensors and the technologies that support them will not, however, be treated here. Instead, this paper focuses on a system that can fully exploit whatever the complement of sensors becomes. This approach draws attention to the satellites that will carry these sensors and their constellation.

**Satellites.** Properly *fusing* space surveillance and reconnaissance data requires putting the right *sensors* over the right *targets* at the right *times*. Very few intelligence questions can be answered with a single pass of a single sensor over a target, and yet that is all current systems generally permit. There are two solutions to this problem. Either build large satellites, each carrying a wide array of sensor types operating simultaneously, or build numerous small satellites, each with a single dedicated sensor. In 2025 the best answer for the SenseNet is the latter. Even today, large satellites can run a staggering \$1 billion a piece; their loss would leave unacceptable “holes” in the mission constellation.

Small satellites, on the other hand, are low in cost for design, construction, and launch.<sup>2</sup> Proliferation of large numbers of these limited-function satellites also contributes to lower overall SenseNet system

vulnerability; any antisatellite (ASAT) attack on individual satellites would only marginally impact overall SenseNet performance. Further, any satellites lost to either ASAT attack or system failure can be quickly, easily, and inexpensively replenished.<sup>3</sup>

The road to 2025 promises satellites as small as a shoe box if current trends continue. Interest in them is growing quickly worldwide. Businesses, governments, universities, and other organizations around the world are starting their own small satellite programs.<sup>4</sup> Industry, lured by “smaller, faster, better, cheaper,” is paying more for research in this area. As a result, technologies needed to support this trend are being developed and demonstrated at a tremendous pace. The International Small Satellite Organization (ISSO) reports 72 lightsats were launched between 1988 and 1994.<sup>5</sup> The Small Satellites Home Page of the World Wide Web, hosted at University of Surrey, United Kingdom, lists 46 small-, mini-, micro-, and nanosatellites currently preparing for launch before the turn of the century.<sup>6</sup> One of these satellites, “Clark” (named after the famous American explorer), has interesting commonalities with SENSAT concepts.

“Clark” is a small satellite project funded by NASA through its Small Spacecraft Technology Initiative (SSTI) program. It is scheduled to be launched in June 1996. This state-of-the-art satellite will carry a multispectral imaging camera that will provide multispectral image resolutions of three to 15 meters, completing global coverage in as few as 20 days at a total program cost of only \$49 million (including launch).<sup>7</sup> The satellite is scheduled to fly on OSC’s Pegasus XL launcher, an air launched rocket that does not require a conventional launch pad.<sup>8</sup> Clark will demonstrate 36 advanced technologies critical to small satellites. These technologies are listed in appendix B. Among them are “automated onboard feature identification” and “image data compression”—technologies that will be of great value in managing the massive data collected by the SenseNet.<sup>9</sup> The ramifications are clear. Small satellites are fast becoming the norm and enabling technologies should mature in time to support a SenseNet by 2025.

**Constellation.** The SenseNet unifies hundreds of satellites into a well-orchestrated whole. The result is a capability closely resembling “Man in the Chair” concepts. At all times, MITCH will be able to monitor any spot on the earth with surveillance SENSATs and focus with reconnaissance SENSATs in all “senses.”

It is possible to construct a SenseNet constellation that guarantees more than one SENSAT of each sensor type over every point on the earth. In fact, this design prudently accounts for SENSAT maintenance,

look angles to the target, and obstructing terrain. Consider a midaltitude network that puts at least two like-sensored SENSATs over all terrestrial points. One simple version would be 18 satellites in circular midearth orbits of 7,000 to 8,000 kilometers (4,350 to 4,970 miles) inclined at 51 degrees to the equator. Three SENSATs would be dispersed in each of six distinct orbits to ensure two SENSATs over every point on the globe.<sup>10</sup> In practice, one such constellation would be required for each SENSAT sensor type. This means if 2025 warriors conclude they need seven different sensor types continuously monitoring all regions of the earth, the total system would involve 42 orbits carrying a total of 126 SENSATs.<sup>11</sup> The exact number is not so important at this point. What is important is the fundamental concept of a constellation of a hundred-plus satellites to achieve the global awareness of the “Man in the Chair.”

Having addressed a constellation that maximizes SenseNet efficiency, it is important to also focus attention on SenseNet communications and data processing. All SENSATs are linked together by high-capacity laser communications that allow them to collaborate in onboard processing and cross-link data. Laser communication links may also tie the SenseNet to the ground-based IntelSpace and users. According to the Air Force Scientific Advisory Board’s recent study, *New World Vistas: Air and Space Power for the 21st Century*, laser links will soon approach capacities of 40 gigabits per second (Gb/s)—the capability of state-of-the-art fiber optic lines in 1995.<sup>12</sup> The study concludes that just one of these 40 Gb/s links could pass enough bits to map the entire world with 10-meter resolution multispectral or synthetic aperture radar (SAR) data every hour.<sup>13</sup>

This conclusion is very promising for the SenseNet! Consider a constellation of 18 radar SENSATs, for example. If each satellite is equipped with one 40 Gb/s link, the entire world could be imaged at 10 meter resolution (including oceans and polar ice caps) every three and a half minutes. It is apparent that communications technology will not significantly constrain the SenseNet system performance. The Future Concepts Division at the USAF Command, Control, Communications, and Computers (C<sup>4</sup>) Agency agrees. They expect immense communication capacity by 2025.<sup>14</sup>

The concept of only downlinking changes to the ground rests on the ability to process and store the current global “master template” on-orbit. *New World Vistas* estimates that a multispectral image of the entire earth requires 1,300 terabits of memory.<sup>15</sup> Although this is well beyond the storage capabilities of

current satellite data subsystems, industry experts expect significant progress in mass data storage and data processing technologies. By 2025, experts easily foresee memory and processing capacity sufficient to store a complete image of the earth and assess real-time collection for changes relative to that picture.<sup>16</sup>

**SenseNet Control.** SenseNet assets are controlled from the IntelSpace. Commands are uplinked to the SenseNet and the collected data is downlinked to the IntelSpace via a network of military and commercial communications channels. According to the Future Concepts Division of the USAF C<sup>4</sup> Agency, this network could span the globe, seamlessly crossing communication system boundaries (military and commercial) without intervention or awareness by users.<sup>17</sup>

On occasion, the IntelSpace will task the SenseNet to directly downlink SENSAT data to a user deployed in the field. For example, a near-real-time, sensor-to-shooter link could warn ground forces of in-theater surface-to-surface missile launches. Following such a request, the IntelSpace will task the SenseNet to collect with the appropriate sensor type in the region of interest. The SenseNet will allocate the tasking to a specific SENSAT, orchestrate collection hand-offs as SENSATs fade beyond the horizon, and facilitate “hand shakes” at the speed of light to relay collected data to a SENSAT in view of the terrestrial user. The last SENSAT to touch the data will then downlink the product to a user whose only action was to request the product from MITCH.

### **Emerging Technologies**

The Clark technology synopsis contained in appendix B provides a basic guide to emerging satellite technologies that are critical to small, affordable, high-performance satellites in the future. Technology advances in electrical power, command and data handling, attitude determination and control, structures, mechanisms, and instruments make the SenseNet realistic by the year 2025. Commercial system engineering and development processes are already driving these advances.

One technology critical to the performance of small SENSATs, but not listed in appendix B, is the data processing algorithms needed to achieve large aperture (high resolution) system performance. This software digitally processes simultaneous multiple views from multiple satellites into a single, high-resolution picture. For many sensor types, resolution drives aperture size, which in turn, drives payload size. Typically, the

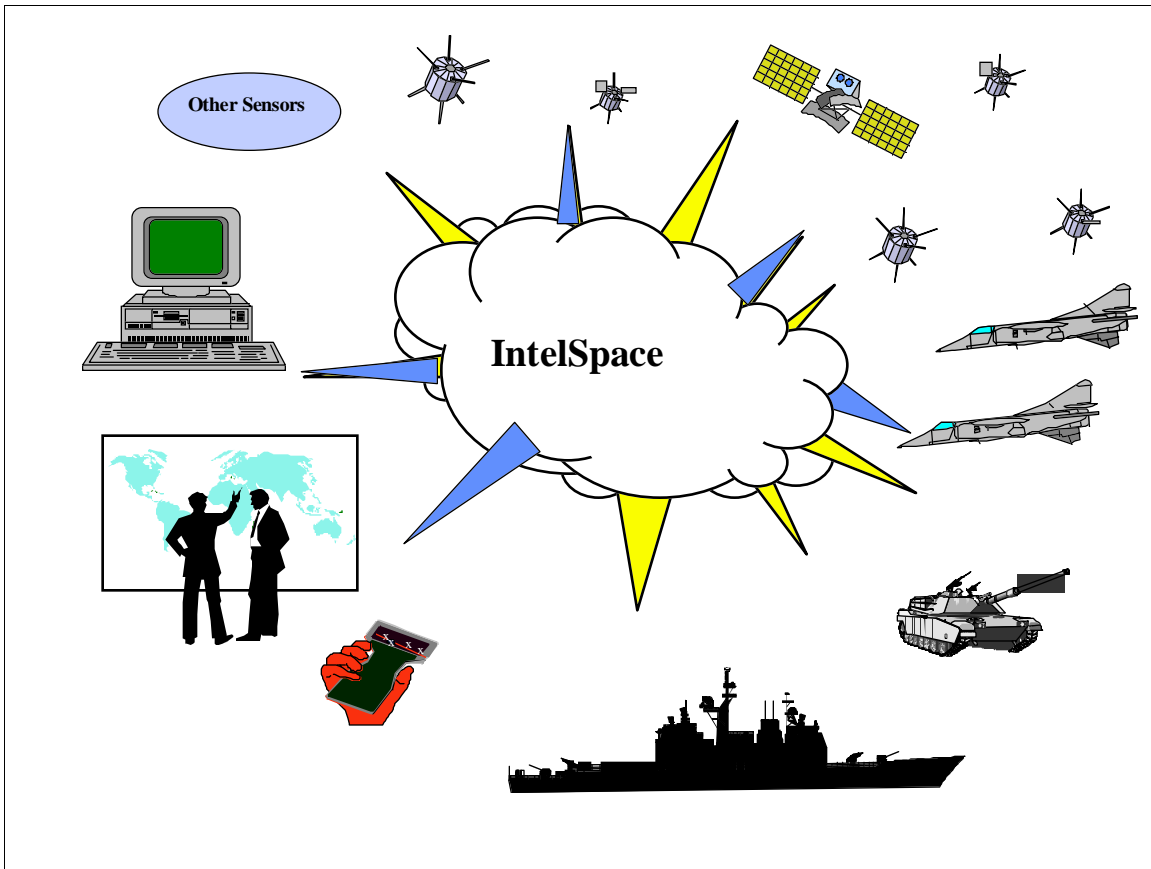
payload is the largest subsystem of any satellite. Large aperture processing is a powerful way of reducing payload size while preserving sensor resolution.

### **SenseNet: Only One Piece**

Sensors, satellites, and constellations do not achieve information dominance by themselves. Without intelligent tasking and smart exploitation of collected data, these elements are nothing but scattered pieces of hardware in space. Further, the low cost and growing availability of these near-future space systems will grant America's future adversaries the same sensors, satellites, and constellations. The path to information dominance lies not only in collecting the most and highest resolution sensor data but also in using that data to deliver the right product, to the right place, at the right time. This is the function of MITCH's "brain" and "nervous system," the IntelSpace.

### **The IntelSpace**

As the global "picture" is acquired by the SenseNet and received from other sources, it enters MITCH's second principle subsystem, the IntelSpace. The IntelSpace ties sensors of all kinds to users at all levels (fig. 3-3). It is important to understand that collection is not limited to SenseNet assets. Other sources, including HUMINT and a variety of air, land, and sea platforms, complement the strength of the SenseNet's "high ground." These sources provide data and/or information that may be undetectable from space. What emerges is an IntelSpace with vast potential to meet two required capabilities: fusion of all collected data into a global picture and single-point user access to the right information.



**Source:** Clipart from Microsoft Clipart Gallery © 1995 with courtesy from Microsoft and CorelDraw! © 1994 with courtesy of One Mile Up Inc.

**Figure 3-3. The IntelSpace.**

The IntelSpace *manages* intelligence information. As discussed earlier, it is subdivided into the Information Domain, MITCH’s “brain,” and the Network Architecture, MITCH’s “nervous system.” In the Information Domain, sensor data is fused, correlated, and stored to create intelligence information and knowledge. It is the sum total of what MITCH knows. Through the Network Architecture, sensor stimuli are relayed to the “brain” for processing; the results are then relayed to users. One could look at the Network Architecture as the “highway” that passes information between collector and user.

Software and hardware are fundamental to both the Information Domain and the Network Architecture. High-speed processors host conventional processing algorithms as well as less traditional artificial intelligence—neural networks, fuzzy logic, and user agents. High data-rate communications and massive storage banks send the right data to the right decision maker at the right time. Users receive this data through hardware ranging from simple personal digital assistants to complex aircraft displays. The following

discussion provides more detail on MITCH's "brain" and "nervous system" and highlights emerging technologies essential to each component.

### **Information Domain**

As the "brain" of the IntelSpace, the Information Domain includes MITCH's analytical ability and the reservoir of intelligence that flows from it. The "engine" driving this analysis is a mixture of artificial intelligence (AI) that includes rule-based decision logic, neural networks, fuzzy logic, and agents. The AI components are smart enough to perform tasks traditionally accomplished by human analysts. When users query MITCH, the Information Domain searches stored data and initiates any new collections required to answer the question. Rule-based logic and trained neural networks make this possible by effectively "thinking through" or determining what data and information is needed to answer the request. Rule-based logic and neural networks also automate the analysis of data once it is collected. Each new piece of data is fused and correlated across the total Information Domain. In other words, new data is integrated with existing data to "paint" all facets of the situation, and it is interpreted within the context of other stored information. At the same time, AI components look for familiar and emerging patterns. These patterns are the building blocks for MITCH's conclusions. In the case of new, emerging patterns, MITCH may "push" conclusions on to the user without cueing.

It is worth noting that data fusion and pattern recognition at a global level are tremendously challenging, perhaps more so than any other aspect of MITCH. Although the technologies will be in place by 2025, their specific application to MITCH will almost certainly dwarf any similar efforts at the commercial level. Perhaps millions of data and information elements will require constant manipulation in response to an ever-changing world situation. That data will run a rigorous spectrum, ranging from simple temperatures to complex HUMINT reports on human intentions. In fact, it is probable that MITCH will require years of human massaging and on-line experience before it can reliably identify, test, and recommend patterns from that near-chaotic set of links.

Even after MITCH is fully initialized and running autonomously, AI will not replace humans in the system loop. Instead, it will augment the human by autonomously performing the myriad of logical tasks



associated with reduction of collected data. Decision making is still left to the human. However, decisions can be made without the burden of first sifting through “mountains” of stored data.

## **Network Architecture**

The network architecture provides the underpinnings for the distributed connectivity and processing of the IntelSpace and serves as MITCH’s “nervous system.” The network will be widely distributed, much like today’s Internet, ensuring survivability. If one node of the IntelSpace is damaged, the effect on the rest of the IntelSpace will be minimal. As with the Information Domain, the Network Architecture runs with conventional processing as well as AI elements. Using these technologies, the network manipulates and moves data back and forth from the SenseNet to the end users.

The Network Architecture, however, does more than just serve as a highway for data and information. Using neural networks, a network “architect” determines when and where to create new data reservoirs and how to link them to the system—providing for more efficient system operation as well as increased survivability. If tasking of the SenseNet is necessary at any time, the Network Architecture relays that tasking from the Information Domain to the SENSATs.

The 2025 concept paper “Automated and Integrated Intelligence Seamless Fusion and Correlation System” proposes neural networks to fuse intelligence data in response to user queries.<sup>18</sup> While this system uses direct user queries and messages rather than the autonomous user agents proposed later in this paper, this system provides a possible intermediate stage between the systems of today and those of 2025.

## **Emerging Technologies**

In order to deliver the IntelSpace by the year 2025, specific technologies must be further advanced. These include artificial intelligence (rule-based logic, neural networks, fuzzy logic, and agents), high data-rate communications, mass storage media with fast input-output capabilities, hardware independence, and high-speed processing.

**Rule-Based Logic.** Rule-based logic is the first of four AI technology areas employed in the IntelSpace. In the start-up of any AI system, human operators preprogram this logic into the system through what is known

as preconditioning. This preconditioning establishes the logical paths from which the IntelSpace will frame its decisions and actions. For example, if SenseNet data shows movement of 300 tanks and the IntelSpace determines these tanks will cross an international border, how will the IntelSpace react? It will not—unless prompted by code that says: “If 300 tanks cross a border, report an invasion.” This code is the *rule*. The strength of rule-based logic is its simplicity. Cause brings effect, however, the simplicity also fosters weakness. To properly account for all possible interpretations of a given situation, millions of rule-based statements might be required. How should the IntelSpace react if only a single tank brigade crosses the border? What about a squadron of fighters? What if the nations are participating in a joint exercise? The fact that rule-based logic exercises black-and-white decision criteria makes it unwieldy for complex problem sets. In addition, there is no way to autonomously adjust the logic for “experience.” These two shortcomings are precisely the reason that AI has floundered over the years and disillusioned so many.

**Fuzzy Logic.** Along with neural networks, fuzzy logic capitalizes on the advantages of rule-based logic while offsetting that technology’s weaknesses. Fuzzy logic allows computers to press beyond binary decision making into variations or approximations. Modern-day examples surround us: the thermometer of an air conditioner, the antilock brakes of a car, or the autofocus of a video-camcorder.<sup>19</sup> It is a discipline crucial to monitoring the global situation—a situation whose elements cannot be defined in one of two states. Returning to the example, fuzzy logic will allow MITCH to go beyond the elementary “300 tanks have crossed the border” and deal with approximations and shades of relative degree. Using this technology with stored data, the IntelSpace might evaluate tank speed, status of targeting systems, and nature of the tank formations to determine if the movement is similar to, or “approximates,” hostile action. In other words, fuzzy logic allows MITCH to turn the raw data from the sensors into an intelligent assessment of the situation.

Although fuzzy logic significantly enhances the effectiveness of complex AI systems, it will not be enough to construct MITCH as envisioned. Neither rule-based nor fuzzy logic permit learning from experience. This shortcoming prevents the IntelSpace from becoming “smarter” than it was on the first day of operation. It means that recent experience, developing patterns, and new relationships would be retained only with the intervention of human operators. But a human role in this area would require tedious combing of data by analysts—precisely what MITCH is designed to eliminate!

**Neural Networks.** Neural networks are valuable to the IntelSpace because they “learn.” They use experience to become better and better at classifying patterns. Exposed to enough examples, they generalize to others never seen. More significantly, neural networks can detect patterns no one knew existed.<sup>20</sup> When used with fuzzy and rule-based logic, this permits adaptive systems that can change with experience.<sup>21</sup>

Physically, neural networks are “computer-based systems that attempt to emulate the processing patterns of the human brain.”<sup>22</sup> A typical neural network is made up of many interconnected processor elements simulating the neurons and synapses of a human brain.<sup>23</sup> Each processing element, or “neuron,” receives a set of inputs from another element and processes the inputs through a summation function using a set of weights applied to each input value. Finally it applies a transfer function to the results to produce an output.<sup>24</sup> This output is then sent along a “synapse” to another “neuron” or fed back to the same processing element. The whole network is “taught” by adjusting the weighted strength of each “synapse” with experience. If we show the net a “G” and it properly responds with a “G,” the synaptic connections are positively reinforced. The net will be more apt to follow that path next time.<sup>25</sup>

To put neural networks into the context of the IntelSpace, consider the example of the tanks crossing the border. Equipped with a neural network, the IntelSpace is now able to assess conclusions in light of *past experiences*. Assume the border in question is peaceful, the tanks are moving slowly, and the two countries in question normally conduct an annual training exercise between armored forces at this time of year. Based on the historical experience and the resulting strong links between “synapses” of the network’s “neurons,” MITCH would likely conclude the tank movement is friendly and not an immediate threat. MITCH would advise appropriate decision makers of the movement but also add the assessment that the movement was characteristic of normal activities between the two countries. Key decision makers would then determine what actions should be taken next. On the other hand, if the described links are weak or not present, the information is more likely to follow a path down “synapses” that would result in a warning that a hostile action may be occurring.

The commercial community continues to move forward in the area of neural networks and is successfully applying them to pattern classification, prediction and financial analysis, and control and optimization.<sup>26</sup> Pattern classification and control and optimization hold the most promise for the IntelSpace.

Pattern classification, for example, is being tested for its ability to detect events in complex particle accelerators.<sup>27</sup> In 2025, one can imagine this capability being used by the IntelSpace to detect events across the globe. Control and optimization research is quickly progressing in such areas as missile guidance and detonation, fighter flight and battle pattern guidance, and optical telescope focusing.<sup>28</sup> This research may prove useful in command and control of the SENSAT satellites and sensors.

**User Agents.** Another emerging technology that plays a key role in MITCH is software user agents. These agents make complex tasks transparent to the user by autonomously collaborating with other user agents and monitoring information.<sup>29</sup> Across the IntelSpace, agents may filter, receive, and detect changes to information. Agents are tailored to the individual user and “learn” user preferences by four different means: observation and imitation, positive and negative feedback, explicit instructions, and advice from other agents.<sup>30</sup>

Having learned the basic preferences and requirements of its user, an agent starts to collect information. If the information is not quite what the user wants, negative user feedback trains the agent to a different course of action. Each time the agent interacts with the user, it learns more about that user’s needs.

Technology for autonomous agents is already in its infancy. An *Association for Computing Machinery* article addressing autonomous agents discusses four different existing agents: an agent for handling electronic mail, an agent for scheduling meetings, an agent for electronically filtering news, and an agent that recommends books, music, or other forms of entertainment.<sup>31</sup> Each agent “learns” the likes and dislikes of its user to determine what mail to keep, what time to schedule meetings, what news articles to send to the user, and what forms of entertainment to recommend. Carrying these tasks into the realm of the IntelSpace, a user agent could “learn” what type of intelligence data its user wants to see. The agent learns what intelligence information a user prefers in much the same way human assistants learn the same from their supervisors.

**High Data Rate Communications.** As computer systems get smarter, faster, and more dispersed, they demand faster and higher capacity communications. This will especially be true for the worldwide network of superprocessors that make up the IntelSpace. Fortunately for the military, the pressures of shrinking OODA loops are felt by the commercial and private sectors as well. As John L. Petersen wrote in his book, *The Road to 2015*, “Everything is going faster, so speed is increasingly being used to measure value.”<sup>32</sup> The

commercial sector is vigorously responding with initiatives to comply. The Internet is already a significant driver for more robust communication links. The prospect of millions of users and consumers “surfing” the Internet has computing industry giants looking for ways to make the Internet more attractive to the average person.

One aspect of that attractive “packaging” will be faster and higher capacity communications. This imperative on speed and bandwidth has already spawned today’s fiber-optic networks. These networks transmit voice, video, and data 10 to 100 times faster than standard copper wiring. Speeds will increase in the near term as performance-limiting interface hardware and electronic transmitters are replaced by optical components.<sup>33</sup> Further advances in all-optical networks are on the horizon. These networks promise another order-of-magnitude leap in transmission rates and capacities.

**Mass Storage Media.** The IntelSpace will store massive volumes of data on physical devices distributed across the network. It will require quick access to any piece of data at a moment’s notice. Optical storage devices, like CD-ROMs and DVDs (digital video disks), foreshadow advances in data storage and accessibility. Researchers are moving to produce the first rewriteable optical storage devices. These rewriteable CD-ROMs employ two technologies: a high-power laser that changes the media’s crystallinity and magneto-optical technology that changes the magnetic polarity of spots on the disk.<sup>34</sup>

Another emerging storage technology is holographic memory. This technology leverages recent three-dimensional optical memory advances to store tremendous amounts of information at very high speeds.<sup>35</sup> Holographic memory systems have been sold recently for use in security systems that retrieve and match fingerprints. Using optical neural networks for pattern recognition, these systems have been retrieving data at speed of a gigabyte per second.<sup>36</sup> Currently, this type of high-capacity mass storage system is only available for write once, read many (WORM) applications, but it may be the next step towards the mass storage systems of the twenty-first century.

**Hardware Independence.** To make it easier for decision makers at all levels to tie-in to the IntelSpace, hardware independence is a necessity. Just five years ago, networking computers in an office required they be compatible with each other. In most cases, this meant the hardware and associated operating systems had to be the same or at least similar. The Internet is changing all that. Systems using Windows, UNIX, Macintosh, and other operating systems are now “communicating” with one another. However, this

communication still requires system-unique software specifically designed to read a common language such as the hypertext markup language (HTML) of Internet home pages.<sup>37</sup>

Further simplification of network hardware and software requirements remains attractive. Software companies are responding by designing computer languages tailored to network computing. For example, Sun Microsystems is launching Java, a language that runs on any machine with a small Java “virtual computer.”<sup>38</sup> Any computer hosting this “virtual computer” can run Java programs resident on any other hardware on the network. The small size of the “virtual computer” code, only 64,000 bytes, suits personal digital assistants and cellular phones very well.<sup>39</sup> Further competition for Internet market share will hone hardware independence to a fine edge. Tapping into the IntelSpace from the battlefield to the White House will not be a problem in 2025.

**High-Speed Processing Technology.** High-speed processing technology is another area holding great promise. Today, microprocessor performance is doubling every 18 months.<sup>40</sup> If performance continues to increase at that rate, processing power will be phenomenal in 30 years. According to one expert, in the year 2020, one desktop computer will be as powerful as all the computers in Silicon Valley today!<sup>41</sup>

### **The Human Role**

The preceding sections outlined a system architecture with powerful capability. In fact, the “cognitive” and processing aspects of MITCH are so promising that some would be tempted to view this system as omniscient or “all knowing.” This presumption would be a mistake. MITCH, for all it offers, still must be seen as a tool to assist the human decision maker. It is a system that first *observes* and then *orients* those observations to a set of logical hypotheses. MITCH attempts to make sense of the global situation. It will never, however, be so certain in all its hypotheses that it can assume responsibility for decisions and actions. MITCH is *not* omniscient and war fighting is too often illogical. Clausewitz had it right: “The art of war deals with living and moral forces.”<sup>42</sup>

## **Training MITCH**

Since war is a human endeavor, MITCH must be initialized and trained with humans at its side. Initialization will predictably start with the objects to be observed and the metrics by which they are to be measured. In other words, humans must identify objects like a T-64 tank and then specify the tank's characteristics. The T-64 tank, for example, has a specific visual, thermal, and signals profile. It moves at particular speeds. It is normally found in certain regions or countries. In essence, the human trains MITCH to recognize objects and prepares it to evaluate all related aspects of that object. The human's next task is to train MITCH to link objects together. The challenge is that the permutations are seemingly infinite and any attempts to manually limit them would be counterproductive. In that regard, MITCH's ability to "learn" provides a solution. Rather than specifying each possible link, humans can train MITCH using historical events. MITCH could search for objects it knows and establish links with other objects based on the historical record.

The last step in MITCH's training is also one that never ends—creating information, and in some cases knowledge. Whereas previous tasks rested on MITCH's ability to recognize patterns in physical objects, this task requires it to recognize abstract patterns in the global situation. Intangibles like time, doctrine, and past experience are linked with more tangible observations to recommend hypotheses. As these hypotheses are evaluated and acted upon by human decision makers, MITCH will require human adjustments. These adjustments will range from the addition of new object links to the input of patterns clarified through 20/20 hindsight.

## **Training the Trainer**

The quality of MITCH's mission contribution rests with the quality of its training at the hands of human tutors. Garbage in, garbage out. Brilliance in, brilliance out. The human trainers have to be well-versed in objects, links, and abstract patterns. However, their education does not end when MITCH is declared operational. On the contrary, MITCH is truly successful when it becomes good enough to train the trainer.

Consider the case of Chase Manhattan Bank. Once that institution trained a neural network in all the variables associated with bogus credit card purchases, the system then trained the trainers. That neural

network poured over historical data and discovered that the most dubious sales were for women's shoes priced at \$40 and \$80.<sup>43</sup> The neural network had created *new* information and passed it back to its human masters. MITCH will provide similar insights. Not only will human analysts benefit from new information, but they will also learn from the way in which MITCH determined it. Indeed, one of MITCH's indirect contributions may be to expand the horizon of analytical thought and stretch the efficiency of what is still the world's most versatile computer, the human brain.

### **Countering Countermeasures**

MITCH is a highly distributed system, tying numerous satellites to an expansive ground network of processing and communications hardware. As a result, loss of any one part of the system will have only a small impact on MITCH's overall performance. Vulnerabilities, though somewhat limited, exist and they include both physical and informational aspects.

**Countering Physical Attack.** Proliferation and networking counter the threat of physical attack against both SENSATs and the IntelSpace. Any attack on a network node would endanger only a small percentage of the total system capability.

Hundreds of small, inexpensive, networked satellites make targeting SENSATs a very expensive operation for any adversary. This countermeasure can be further strengthened by launching redundant satellites or by developing a launch capability that can deploy several satellites on-orbit with only short notice. Certainly the proposal to use smallsats in MITCH begs for such a launch program.

Proliferation and networking also counter physical attack on the IntelSpace. In 1969, the DOD kicked off a project called ARPANET. That project reduced the vulnerability of critical computers by dispersing them for survivability and networking them for reliability. That reliability depended on dynamic rerouting. If one of the network links were to come under attack, the traffic could automatically be rerouted across other links.<sup>44</sup> Today, the ARPANET has blossomed into what we know as the Internet and its resistance to attack was demonstrated in the Gulf War of 1991. In that war, the US military struggled to completely knock out the Iraqi command network. It seems the Iraqis used commercially available network routers with standard



Internet routing and recovery technology. Proliferation and dynamic rerouting worked.<sup>45</sup> These principles are proposed again for MITCH's IntelSpace architecture.

**Countering Deception and Security Breaches.** Countering the threat to MITCH's informational integrity boils down to keeping bad data out of the system and bad people off the system. Since MITCH is automated to a degree, bad data is most dangerous when interjected through enemy deception. Deception intentionally misrepresents the enemy's intentions through legitimate collection and hopes for a favorable cascading effect in the IntelSpace's conclusions. Two design features of MITCH counter this threat. First, the number, type, and around-the-clock nature of SENSATs make any cohesive attempt at major deception a significant undertaking. The deception must play to numerous sensors and orchestrate a bogus story through imagery, communications traffic, thermal sensors, and many others. The deception must endure without pause since SENSATs will always be in view. Second, should the enemy achieve these objectives, MITCH's human interface serves as a valuable second check.

Preserving information integrity by keeping bad people off the IntelSpace leads to a tried-and-true security measure: individual authenticators. MITCH will support perhaps tens of thousands of access points, from an infantryman's pocket communicator to a super computer in a large intelligence operation. With so many entry points, the chore is not to prevent unauthorized possession of access media, but rather to prevent unauthorized system entry when that access media falls into the wrong hands. In MITCH, the required authentication of users could draw on a fusion of sorts, the fusion of state-of-the-art password technologies, deoxyribonucleic acid identifiers, retina scans, fingerprint scans, voice recognition, and others. In addition, the IntelSpace will allow authorized users to only access the data they "need to know," thus limiting the damage of any given compromise.

### **Operational Analysis**

The system architecture and emerging technologies presented in this chapter deliver the five required capabilities central to core competencies of global awareness and information dominance. Together, MITCH's SenseNet and IntelSpace provide and protect the right product, in the right place, at the right time.

However, MITCH will not be evaluated solely on its ability to meet proposed requirements. Shrinking government budgets demand that it must also offer more “bang for the buck” when compared to a diverse range of other initiatives that also meet their requirements. The **2025** effort recognizes this demand and is conducting an operational analysis at the Air Force Institute of Technology (AFIT). In that analysis, the AFIT operational analysis team created generic tasks, force qualities, and measurands to score all **2025** concepts. Appendix C addresses these tasks and their subordinate metrics in the form dictated by the AFIT team. It rates MITCH’s predicted system performance for each and justifies the values assigned.

### Notes

<sup>1</sup> SPACECAST 2020, Air University, “Leveraging the Infosphere: Surveillance and Reconnaissance in 2020,” AU study, 22 June 1994.

<sup>2</sup> R. A. da Silva Curiel (No date). *The Small Satellite Home Page* on-line internet, 12 February 1996, available from HTTP: <http://www.ee.surrey.ac.uk/CSER/UOSAT/SSHP/sshp.html>.

<sup>3</sup> The **2025** white paper “Spacelift” defines a path to a cost-effective solution to the replenishment question. Its air launched space vehicle (ALSV) would provide a completely reusable vehicle that is safe, responsive, and cost effective. Each of these vehicles would be able to provide up to three satellite launches per day with a surge capability of 12 space sorties per day for a period up to a week long. This would be a robust and adequate replenishment capability should the SenseNet suffer even a significant loss of SENSATs.

<sup>4</sup> Da Silva Curiel (No date). *The Small Satellite Home Page* [Online].

<sup>5</sup> William Gande, “Smallsats Come of Age?” *Ad Astra* 6, no. 6 (November/December 1994): 22.

<sup>6</sup> R. A. da Silva Curiel (No date). *Satellites in the making . . .* on-line internet, 12 February 1996, available from HTTP: <http://www.ee.surrey.ac.uk/CSER/UOSAT/SSHP/future.html>.

<sup>7</sup> CTA Incorporated (No date). *Clark Technology Synopses*, on-line internet, 12 February 1996, available from HTTP: <http://www.futron.com/clark/clark.clark.html>; Da Silva Curiel (No date). *Satellites in the making . . .*

<sup>8</sup> Gande, 22.

<sup>9</sup> CTA Incorporated (No date). *Clark Technology Synopses* [Online].

<sup>10</sup> William B. Scott, “Russia Pitches Common Early Warning Network,” *Aviation Week & Space Technology* 142, no. 2 (9 January 1995): 46.

<sup>11</sup> The preceding data recommends six orbits for each sensor type and if seven sensor types are desired, the number of orbits required is 42. To provide global coverage, three satellites are required per orbit resulting in a total of 126 satellites.

<sup>12</sup> USAF Scientific Advisory Board, *New World Vistas: Air and Space Power for the 21<sup>st</sup> Century*, summary volume (Washington, D.C.: USAF Scientific Advisory Board, 15 December 1995), 20.

<sup>13</sup> *Ibid.*, 23.

<sup>14</sup> Notes from meeting with the Future Concepts Division, USAF C<sup>4</sup> Agency, 28 February 1996.

<sup>15</sup> *New World Vistas*, summary volume, 20.

<sup>16</sup> John Verity, “Meet Java, the Invisible Computer,” *Business Week* 3452, no. 1 (4 December 1995): 83.

<sup>17</sup> Notes from meeting with the Future Concepts Division, USAF C<sup>4</sup> Agency, 28 February 1996.

## Notes

- <sup>18</sup> 2025 Concept, No. 200059, "Automated & Integrated Intelligence Seamless Fusion & Correlation System," 2025 Concepts Database (Maxwell AFB, Ala.: Air War College/2025, 1996).
- <sup>19</sup> Bart Kosko, *Fuzzy Thinking* (New York: Hyperion, 1993), 182–185.
- <sup>20</sup> Daniel McNeill and Paul Freiberger, *Fuzzy Logic* (New York: Simon and Schuster, 1993), 229.
- <sup>21</sup> Kosko, 203.
- <sup>22</sup> Carol E. Brown, James Coakley, and Mary Ellen Phillips, "Neural Networks: Nuts and Bolts," *Management Accounting (USA)* 76, no. 11 (May 1995): 54.
- <sup>23</sup> Kosko, 206.
- <sup>24</sup> Brown, Coakley, and Phillips, 54.
- <sup>25</sup> McNeill and Freiberger, 230.
- <sup>26</sup> Bernard Widrow, David E. Rumelhart, and Michael A. Lehr, "Neural Networks: Applications in Industry, Business and Science," *Communications of the ACM* 37, no. 3 (March 1994): 94.
- <sup>27</sup> *Ibid.*, 95.
- <sup>28</sup> *Ibid.*, 96.
- <sup>29</sup> Pattie Maes, (1994), "Agents that Reduce Work and Information Overload," *Association for Computing Machinery. Communications of the ACM* [Online], 30. Available: ProQuest Online [1996, January 27].
- <sup>30</sup> *Ibid.*
- <sup>31</sup> *Ibid.*
- <sup>32</sup> John L. Petersen, *The Road to 2015: Profiles of the Future* (Corte Madera, Calif.: Waite Group Press, 1994), 70.
- <sup>33</sup> Vincent W. S. Chan, "All-Optical Networks," *Scientific American* 273, no. 3 (September 1995): 56.
- <sup>34</sup> Suzanne J. Thompson (No date). *Mass Storage Technologies* on-line internet, 14 February 1996, available from HTTP: [http://www.nml.org/publications/NML\\_TR/task4\\_final/9\\_mass\\_storage.html](http://www.nml.org/publications/NML_TR/task4_final/9_mass_storage.html).
- <sup>35</sup> Clarence A. Robinson, Jr., "Holographic Storage Media Could Eclipse Optical Disks," *SIGNAL* 50, no. 6 (February 1996): 31.
- <sup>36</sup> *Ibid.*
- <sup>37</sup> Amy Cortese with John Verity, Kathy Rebello, and Rob Hof, "The Software Revolution," *Business Week*, no. 3453 (4 December 1995): 78.
- <sup>38</sup> Verity, "Meet Java, the Invisible Computer," 82.
- <sup>39</sup> *Ibid.*, 83.
- <sup>40</sup> David A. Patterson, "Microprocessors in 2020," *Scientific American* 273, no. 3 (September 1995): 51.
- <sup>41</sup> *Ibid.*
- <sup>42</sup> Carl von Clausewitz, *On War*, ed. and trans. Michael Howard and Peter Paret (Princeton, N. J.: Princeton University Press, 1976), 86.
- <sup>43</sup> McNeill and Freiberger, 229.
- <sup>44</sup> John R. Levine and Carol Baroudi, *The Internet For Dummies*, 2d ed. (Foster City, Calif.: IDG Books Worldwide, Inc., 1994), 11.
- <sup>45</sup> *Ibid.*, 12.

## Chapter 4

### Concept of Operations

*Never before have armies been challenged to assimilate the combined weight of so much change so rapidly. In this environment, the payoff will go to organizations which are versatile, flexible, and strategically agile, and to leaders who are bold, creative, innovative, and inventive. Conversely, there is enormous risk in hesitation, undue precision, and a quest for certainty.*

—Gen Gordon Sullivan  
US Army chief of staff

Though directed towards an Army audience of today, these words embrace both the challenges and keys to success in almost any foreseeable future of 2025.

MITCH stands as a revolutionary step beyond the traditional intelligence-gathering systems of today. The preceding chapter described the system and the technologies that could make MITCH a reality. However, the “Man in the Chair” concept requires more than just a system. It also requires a new way of thinking about how we interact with the intelligence systems. To provide the right product, to the right user, at the right time, MITCH must be more than an evolutionary combination of year 2025 processors, sensor and satellite technologies, and communications. Only when tied to an effective concept of operations will MITCH meet requirements such as the Army’s Force XXI “efficient, effective, tailorable, and flexible intelligence support in multiple locations.”<sup>1</sup> The concept of operations for MITCH includes the following three key areas:

1. “Push You/Pull Me” information flow,
2. Global “PlugIn Play,” and
3. “Right Product” for all operational levels.

Though these concepts have been briefly introduced before, they are covered in full detail here since they are a critical part of MITCH's capabilities. This chapter also discusses how users and decision makers at all levels would be supported by and interface with the system. Finally, to bring together the elements of MITCH's system design and concept of operations, a vignette illustrates how MITCH would participate in future operations.

### **“Push You/Pull Me”**

The first concept, “Push You/Pull Me,” is really the core operational concept of the system. “Push You” refers to the ability of the system to *cue* the user when the system finds information that might be critical and/or relevant. “Pull Me” means that the user would be able to request and receive specific information on demand. The specific details of each “Push You/Pull Me” operation would be performed by agents working within the network previously discussed. For example, the commander of a tank brigade might request a current display of his forces and those opposing him. His agent, continually monitoring the location of the tank brigade, would acquire the necessary information from wherever it was located on the system and subsequently display it—much like current agents that can locate and display information from the Internet's World Wide Web. The tank brigade commander *would not need to know where or how to get the desired information*. His request to the system simply “pulls” the information needed.

On the other hand, the system would also be able to provide *unsolicited cues* of critical activities that might otherwise go unnoticed or unasked for—critical activities that could mean the difference between victory or defeat in the global battlespace. For example, in surveillance of the battlespace, the system might identify unusually large numbers of trucks moving from rear-area supply depots towards the front. The system would cue leaders not only to the movement but also, because of assimilation of historical and current data, to further actions the enemy might be preparing to take. On request, MITCH could provide detailed rationale supporting those conclusions.

### **Global “PlugIn Play”**

The second concept, Global “PlugIn Play,” means that any user can “PlugIn” to the system from any place, any time, and immediately “Play” or operate on the system. This concept of operations also includes the ability of additional sensors to “PlugIn” to the network and have immediate data “Play” or integration into the IntelSpace. “PlugIn” could be by almost any form of communication media including fiber optics, satellite link, conventional radio, and laser. End users could “PlugIn” from any operational level. The “Play” concept eventually goes beyond the idea of just accessing (in the case of the user) or providing (in the case of a sensor) data. Combined with the “Man in the Chair” concept, “Play” takes on a more human definition—becoming an integral part of an activity. It means that the system not only provides information to each user but also improves the quality of information on the system through what it “learns” from interactions with each user. In addition, with the “PlugIn” of new sensors, the system does not just provide different displays to users; it integrates or “Plays” the information into the system to refine and improve the quality of information.

### **“Right Product”**

The final concept of operations, “Right Product,” means just that. The system will provide an integrated, timely product to any user—strategic, operational, or tactical—in the format needed by that user. Going a step further, the system could use personal software agents to provide tailored products to each individual user. For example, as users access the system, a personal agent would be created that would “interview” the new user to determine what level of operational information is required as well as learn specific information important to that user. The more the user uses the system, the more the agent would be able to “look over the shoulder” of the user and eventually anticipate what information the user would require. The agent may acquire that information and display it in the most effective manner. In addition, the agent would continuously monitor the system and alert the user when it found any information which might be critical. Relevance of information would improve as the agent learned from user feedback.

Finally, the agent could “ask for advice” from other agents that performed similar tasks to determine appropriate actions for a given situation. These concepts all build upon software agents already in existence or under development. Existing agents already discussed perform such tasks as filtering electronic news to find desired pieces of information, recommending books based on preferences of the reader, and automatically classifying concepts from electronic meetings.<sup>2</sup> These “agents” help bring “life” into the “Man in the Chair” concept. They provide the triggers that cue the “man” to focus his attention in a given area and subsequently acquire the information through his different “senses.”

### **A Word on Users**

The tenets of “Push You/Pull Me,” “PlugIn Play,” and “Right Product” seek to guarantee that MITCH is flexible enough to meet all users’ needs on their own terms. By not focusing on specific user interfaces and systems, these three generic capabilities provide user access for any mission, across any medium, and in any format. In a manner of speaking, it is MITCH’s job to provide the proper information; it is the user’s prerogative to decide how and where that information should be exploited. Even though the user lies outside MITCH’s formal system boundaries, it is still beneficial to discuss that community in general—if only for the purpose of reinforcing how flexible MITCH really is.

### **Supporting Users across Any Mission and Medium**

To begin, MITCH is able to support users in any mission and across any medium. It accomplishes this support through a robust dispersion of assets across the SenseNet and IntelSpace. “PlugIn Play” is a key concept; it allows users at all levels of war to leverage their efforts with MITCH, no matter where they are.

The phrase “users at all levels of war” typically leads many to envision a wide range of personnel engaged in strategic, operational, and tactical tasks. It helps capture the idea that MITCH offers advantages to a range of decision makers from the White House to the lowest enlisted ranks. This interpretation, while correct, should be expanded to recognize that the 2025 user may increasingly be another machine or computer. In that time frame, some mission areas will be optimized by removing humans from the decision

loop. As the OODA point approaches, automated action may succeed where human decision and action may fail.

Theater missile defense exemplifies one area where MITCH, coupled with target acquisition systems, could provide a decisive edge. By exploiting MITCH's global awareness and its ability to pinpoint objects with sub-meter accuracy, enemy threats quickly become targets. The increased presence of surface-to-air missiles, ground-launched cruise missiles, advanced aircraft and armor, and highly motorized infantry, pushes war fighters toward an automated philosophy of "shoot now and ask questions later."

### **User Interfaces**

Whether human or machine, users will view MITCH's information via an exciting array of formats. Each format must be tailored to specific mission areas with the goal of expediting decisions and actions. The spirit of this goal and the demands of 2025 probably sound the death knell for today's two dimensional displays. Instead, envision 3-D holographic displays of the situation, voice exchanges, tactile inputs that prompt actions, and other alternatives. Advances in miniaturization will allow "displays" on every weapon system, including the soldier. Imagine devices that inhabit the human body, closely integrating with human ears, eyes, and fingers. In the end, MITCH is designed to take advantage of any of these approaches. It is the user's call to make.

### **MITCH at Work**

MITCH can make a reality out of today's and the foreseeable future's seemingly impossible tasks—providing the needed cornerstone of global awareness and information dominance. This system could monitor the globe in near real time, constantly looking for events that could change the strategic landscape. At the same time, MITCH would provide operational commanders with the "fused" information they need to ensure success on the battlefield. Finally, combined with the right strike vehicle, the system could enable the air and space forces of 2025 to achieve such current Air Force goals as "get those [ballistic missiles] with attack operations before they ever have a chance to launch."<sup>3</sup> In short, MITCH is a system that would



provide fused products (integrated, analyzed, right place, right time) to users including the president of the United States, theater commanders, fighter pilots, or infantry squad leaders.

The following illustration shows how MITCH might be incorporated in tomorrow's operations:

The date is 1 January 2025. Over the last decade, portions of the SenseNet have been carefully placed in orbit above the earth. Today, the SenseNet is constantly watching, constantly looking for change, constantly learning about events occurring on the distant earth below. At present, the network consists of five types of small and microsattellites, all in low earth orbit. The constellation, each sensor type providing a separate "sense" to the network, is arranged to ensure global coverage at all times. Currently, the SenseNet is capable of multispectral imaging, signal intelligence, optical imaging, magnetic signature detection, and synthetic aperture radar imaging. Additions to the constellation will be added over the following years to increase sensor types and improve "awareness" of the system.

As each satellite circles the earth, it maintains an independent and total database of the earth's surface for its particular sensor type. As it scans the surface, it relays changes in that database to other satellites in the constellation and to the IntelSpace below. New information is distributed throughout the IntelSpace to ensure the system cannot be rendered inoperable by the loss of any one or even a number of nodes. Just like the "Man In The Chair," the system is constantly combining information from all its "senses" into a single picture of the surface. Working constantly and in parallel, much like the synapses in the human brain (but at a much larger scale), system agents analyze this global image to identify all aspects of what is on and above the earth below. System agents cross check their "views" on global events in a way similar to an intelligence staff working together to provide a commander with the best possible "picture" of a situation. Like the "Man In The Chair," the system synthesizes what it "sees" into a much broader understanding of events.

By the 4th of January, MITCH pieces together Iranian intentions to launch a new attack on Iraq. The system notifies the president, secretary of defense, Joint Staff, EASTCOM staff, and other key agencies and individuals of the activities. When queried by the president, the system displays a graphic image of the Iran/Iraq border and, using appropriate symbology, displays five armored and infantry divisions moving toward the border. Upon voice command, the system zooms in on a specific area and shows the president the individual vehicles it is tracking. In conjunction, the system provides the president with communications intelligence supporting the system's analysis.

At the same time in another part of the globe, the commander of JTF LIFE GUARD arrives at his headquarters for his second day of humanitarian operations in India. To date, over 10 million people have died from massive floods within the country. The prime function of his task force is to locate people who have been isolated by those floods and provide them with needed supplies for survival—a stopgap until the waters retreat. As the JTF commander steps into the operations room, MITCH has already identified key populated areas isolated by flooding and has identified the location of people within those areas. The JTF commander quickly assigns his available airlift assets to deliver supplies to those areas.

Back in the Persian Gulf region, MITCH has continued to monitor the situation between Iran and Iraq. The United States, as part of a coalition of United Nations forces, has a squadron of transatmospheric strike vehicles on alert to respond immediately to any offensive actions by Iran. At 2003 zulu on 5 January, MITCH alerts the president, national command structure, and strike squadron commander that Iran has prepared eight "Tehran" theater ballistic missiles for immediate launch. Three of the five armored divisions are shown rapidly moving toward the border. Upon this notification, the president orders the

strike vehicles to immediately respond if Iran crosses the border and to destroy the missiles if Iran decides to use them.

On board the strike vehicles, MITCH provides information to onboard computers for a continual display of the route to the theater. Upon request by the pilots, each agent displays the tactical situation along the border of the two countries using graphic symbology to show the layout of ground forces, air forces, and the location of the eight missile launchers. Shortly after the strike vehicles arrive in the area, MITCH identifies five tanks crossing the border. The pilot of the first vehicle immediately targets and destroys all five tanks. At the same time, MITCH alerts the pilots of the second and third vehicles that it has detected rocket ignition of five of the eight "Tehran" missiles. The system instantly provides targeting information to the strike vehicles' onboard systems and the missiles are destroyed two seconds after the missile engines fire.

### Notes

<sup>1</sup> Department of the Army, *Army Focus 94, Force XXI*, September 1994, 39.

<sup>2</sup> Toshinori Munakata, (1994), "Commercial and Industrial AI," *Association for Computing Machinery. Communications of the ACM* [Online], 23, Available: ProQuest Online [1996, January 27]; Pattie Maes, (1994), "Agents That Reduce Work and Information Overload," *Communications of the ACM* [Online], 30, Available: ProQuest Online [1996, January 27]

<sup>3</sup> Bill Gertz, "The Air Force and Missile Defense," *Air Force Magazine* 79, no. 2, (February 1996): 73.

## Chapter 5

### Investigation Recommendations

Does the United States (US) want to succeed in the battlespace of 2025? Is it in America's best interest to field the capability vividly portrayed in the last two chapters? The answer must certainly be an *emphatic yes!* National survival will increasingly depend on getting the right information to the right decision maker at the right time. MITCH offers all three and provides the cornerstone for revolutionary comprehension of the global battlespace.

Certainly, America's steps will be challenged all along the way. Both enemies and friends are sharing in the technological explosion of this age. They, too, aspire to acquire systems that provide "global awareness" and "information dominance"—systems that threaten to be superior to our own. In just one example, Andrew Krepinevich, Jr., notes that Russia is energetically developing concepts for "Reconnaissance Strike Complexes." These complexes strive to dramatically reduce Russian decision loops by electronically linking sensors, target acquirers, and weapons.<sup>1</sup> The US cannot allow this to go unchallenged. Only a focused strategic plan will put us in the driver's seat—a plan that brings MITCH on-line as soon as possible. This final chapter lays the ground work for that plan and suggests four areas for further investigation: technology considerations, cultural considerations, acquisition methodology, and acquisition management.

## **Technology Considerations**

Maj Gen Garrison Rapmund, USA, Retired, foreshadowed perhaps the most significant aspect of any strategic plan, “keep the vision.” After receiving a briefing capturing the essence of MITCH, the general said little about technologies, but a lot about the analogy of the “Man in the Chair.” He noted that Washington, D.C., desperately needs a clear vision of the system end-state. The “Man in the Chair,” he noted, provides one. It provides a vision that allows decision makers to evaluate an infinite stream of “interesting” technologies, recognize the ones that advance the concept of MITCH, and fund them.<sup>2</sup> Keep the vision. Insist on “major league” competencies in global awareness and information dominance. Do not let skepticism rule out what may truly be possible in 2025.

The general’s call to adhere to “the vision” becomes increasingly significant once one realizes the commercial sector will develop the major share of MITCH’s processing, space, and AI technologies. Systems that sense and evaluate their environment with human precision are potentially very lucrative products. The profit motive, and the fact that these systems bring tremendous efficiencies to nearly every industry, will drive overwhelming commercial motivation to push the state of the art. In light of this impetus, a clear government vision of MITCH provides the framework for recognition and application of commercial advances.

## **Commercial Advances**

Consider today’s commercial advances. Current estimates predict that desktop computers in 2020 will be “as powerful as all the computers in Silicon Valley today.”<sup>3</sup> By the year 2000, the 66-satellite Iridium system promises to provide worldwide portable telephone service. Shortly thereafter, the 840 small satellite Teledesic system promises to provide near worldwide transmission of video and sophisticated digital information.<sup>4</sup> In remote sensing, commercial planners look to soon deploy small, multispectral and optical imaging systems with relatively high resolutions.

Commercial projects like AND Corporation’s Holographic Neural Technology and Taiwan’s neural-network IC Alliance are aggressively addressing neural network parallel processing. Taiwan’s neural-

network IC Alliance is currently developing reasonably priced neural-network integrated circuit chips for commercial use.<sup>5</sup>

Companies like CYC in Austin, Texas, promise to lead the way to software agents with the ability to take individual patterns and determine broader concepts.<sup>6</sup> By 2025, these software agents may well teach themselves and evolve new and even more effective agents.<sup>7</sup> The list goes on. But what does this commercial development mean for MITCH? It means the United States will not have to pursue expensive development and acquisition programs for many of MITCH's key technologies. Many technologies will be available off-the-shelf at a fraction of the cost of a government procurement program. The US will, however, have to establish a critical framework from which to recognize and apply commercial advances. Americans must work hard at "knowing it when they see it." MITCH, as a vision, helps meet that challenge.

### **Areas Requiring Military Emphasis**

Although commercial involvement will drive nearly every technology required by MITCH, there are two areas that merit DOD emphasis—network security and applications programming.

The sheer size of MITCH's network and its myriad of users produces a security challenge that probably exceeds commercial requirements. Unquestionably and absolutely, unauthorized users must not gain access to MITCH. The security, however, of an architecture spread across earth and sky is inherently at risk. The risk is compounded by the need to grant users access to the system at all levels of war. Today's most secure procedures—retinal scans, voice templates, fingerprints, and deoxyribonucleic acid matching—may not be enough to limit the risk of enemy intrusion. New and revolutionary techniques must be developed. In addition to protecting the system from "hackers," MITCH must also control the access of authorized users. Recognizing a user's authorized security clearance and restricting access to the IntelSpace accordingly is a huge challenge. As data is fused into information and possibly knowledge, where and how does the IntelSpace draw the line? It is a question that the architects of MITCH must address. Their solution must delicately balance "need to know" considerations with the user's requirement for complete answers.

A second area requiring vigorous military development is the area of applications programming. As alluded to in earlier sections, the "long pole" to MITCH is not whether technologies will exist, but in how the

technologies are applied to the enormous task that MITCH faces. Intelligent pattern recognition at a global level requires conventional processing, AI, and agent applications tailored to the complex subtleties of interpreting world events. Programming and initializing MITCH will require extensive efforts from developers and users. It will be a long process that begins with solutions to small, well-defined problems and ends with a system capable of interpreting large, ill-defined scenarios. It is a process that must start now.

### **Cultural Considerations**

Time will prove the technological feasibility of MITCH. However, another issue is equally as important in determining MITCH's success—cultural acceptance. For years the military has “stovepiped” intelligence data in separate organizations. Imaging systems, for example, operate within a community much different than systems dedicated to signals collection. As a result, fusion of data seldom occurs. When it does, it is only through rare, deliberate efforts. This structure, motivated by cold war security imperatives to compartmentalize US technology, must radically change if MITCH is to reach its full potential. Department of defense and other US agencies must move to integrate their collection, processing, and dissemination systems. Decision makers and the supporting intelligence community must begin to think in terms of fused end-products, not in terms of independent sensor types. This cultural shift will take time but must occur.

In addition to breaking down “stovepipes,” Americans must become less skeptical about using automated information systems as decision-aiding tools. As Brig Gen William Harmon notes, battlefield commanders must first trust automated intelligence before they will use or even build it.<sup>8</sup> This trust can only be developed over time and will evolve with each incremental step in technology—a result that has strong implications for the way the US should go about acquiring MITCH.

### **Acquisition Methodology**

Considering both technology and cultural factors, an acquisition strategy for MITCH should follow two principles. First, the US should leverage commercial advances to the greatest extent possible. Second, from

now until the year 2025, the military should build prototypes that, with each iteration, move closer and closer to the MITCH concept.

This acquisition strategy gives MITCH's architects the flexibility to test promising technologies as they emerge. It allows them to experiment before locking into the final system architecture. Since prototypes are relatively inexpensive, the costs associated with shifting to the next generation of products are more affordable. As a result, the development community is less likely to become mired in old technology for budget reasons. Another advantage to prototypes is their reduced scope of operation. This lets MITCH's developers work system problems on a small scale before tackling problems for a large, complex system. In the end, prototypes and the flexibility to stay with the tide of commercial developments will improve the final configurations of MITCH.

In addition to helping steer technology, prototyping will also help transform the user culture. With each prototype delivered, users will grow increasingly accustomed to working with automated information systems. They will thoroughly train with what MITCH offers. They will find ways to use MITCH in an ever widening range of day-to-day operations. When the full version of MITCH is delivered in 2025, it will be to users that have already grown to trust the system.

### **Acquisition Management**

Managing the acquisition of MITCH presents a significant challenge. Without proper order, the methodology discussed might easily evolve into a set of disjointed technology efforts. As a result, someone must orchestrate MITCH's acquisition so that the end product is a single, integrated whole. The job is too big for a single program office. Instead, it is a job for a larger organization, similar in style to the old Strategic Defense Initiative Office (SDIO). The SDIO skillfully guided a plethora of technologies toward the vision of a missile defense shield. It loosely guided technology development while holding tight to a vision. A similar organization must do the same for MITCH. This organization must carefully balance centralized control of MITCH, the vision, with decentralized control of the experiments and technologies that will one day achieve it. In addition, the organization must foster cooperation of the commercial and government sectors.

## **Concept Development from Here**

The first task of the managing organization must be to further clarify and refine what MITCH is as a concept. The nation's finest minds must pick up where this white paper leaves off. During the concept development phase, government think tanks, contractors, and military users should jointly identify what is required of MITCH. What must it do? How must it do it? Who must it do it for? In essence, the all-important system vision must be expanded in more detail. This phase will especially seek to identify required technologies that will remain underdeveloped in the commercial sector. Commercial interest in some areas can be encouraged through government funding for research and development. The remaining technologies, however, should be assigned to defense laboratories or contractors for early concept work. In addition to conceptualizing the elements of MITCH, the US must also develop a picture of the supporting systems required to make MITCH a reality. Spacelift is one good example. This and other partners in the total system must be considered as early as possible.

Once MITCH has matured as a concept, developers should begin building the pieces. Their actions must be guided by development standards. These standards will define the interfaces and protocols that plug users and sensors into MITCH through any communications medium. They are the key tools in the managing organization's ability to synchronize parallel developments while still permitting design flexibility.

## **SenseNet Evolution**

Over the next 30 years, American on-orbit constellations will see three more generations of surveillance and reconnaissance satellites—the result of expected satellite lifetimes. In replenishing these constellations, the US should move away from today's large satellites to a distributed network of numerous smallsats. Technologies fundamental to the SenseNet must find their way on-orbit with each successive satellite generation. One strategy to that end is to drive satellite size down while holding sensor performances at current levels.



## **IntelSpace Development**

Just as today's satellite constellations presage the SenseNet, so today's systems for intelligence processing and dissemination presage the IntelSpace of 2025. Appendix A lists no fewer than eight such systems and MITCH's architects would be wise to heed the corporate lessons learned.

Drawing on these lessons and armed with a clear vision of MITCH, developers must focus first on AI core technologies. Artificial intelligence (AI) is the engine that drives the most critical functions of the IntelSpace. Tailoring it to suit MITCH will require extensive applications programming, an effort that calls for a significant cadre of trained programmers very early in the development. As alluded to in previous sections, prototypes will be the tool used by IntelSpace programmers to incrementally grow capability. Prototypes must first demonstrate competence in fundamentals before progressing to broader challenges. For example, the ability to reliably recognize the pattern of a tank is basic to the more challenging task of concluding an invasion is in progress. Measuring such performance will require sophisticated and detailed test cases. To provide continuity from prototype through operational system, the US must train personnel for early development of these complex test cases.

Eventually, AI and more conventional processing programs will mature to the point where system prototypes can begin exercises with live data collection. These system prototypes will connect AI with the commercial sector's best communications, mass storage media, and processors. Overlaying it all will be the fruit of concerted American efforts to provide reliable network security. The most successful prototypes should be offered to small cross sections of the operational community for trial periods. Feedback from these users will ultimately strengthen MITCH's human-machine interface.

## **Supporting Acquisitions**

The success of MITCH depends on and is influenced by other supporting acquisitions. Two prominent examples are user devices and spacelift.

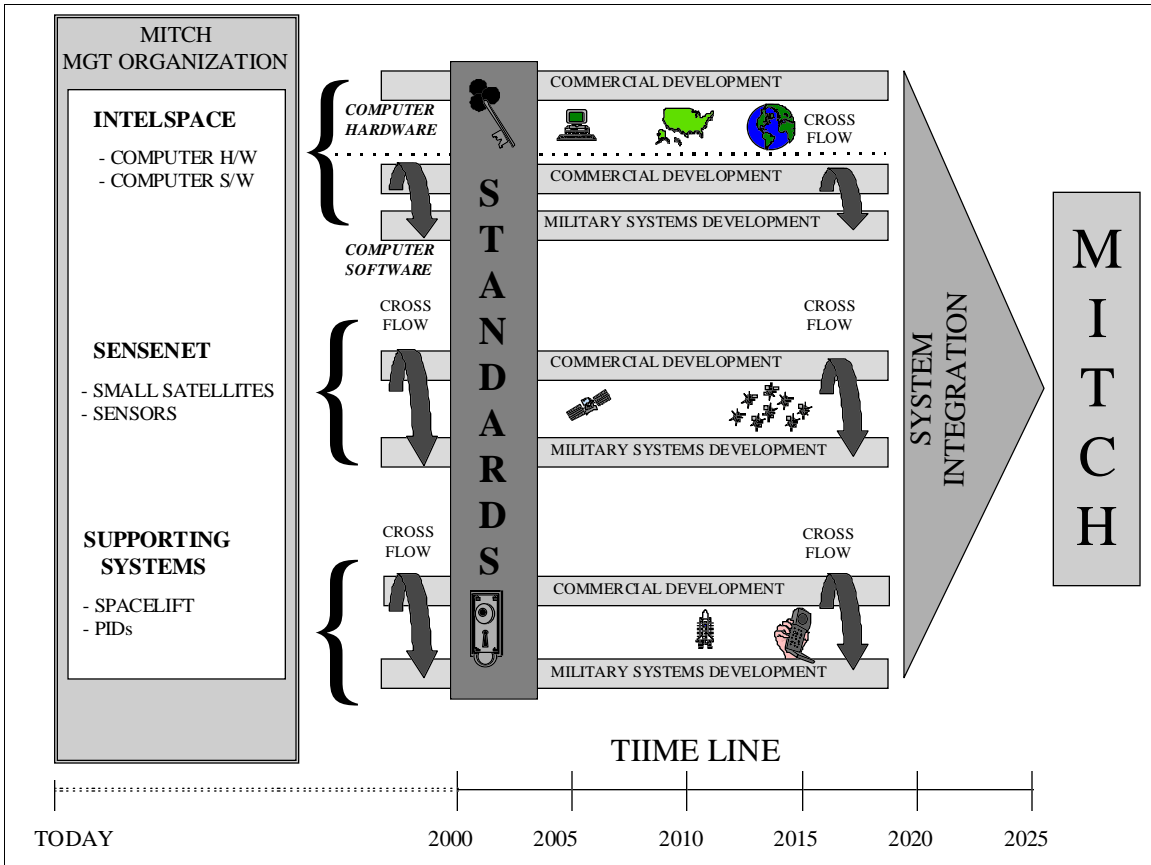
Outside MITCH's system boundaries, user devices will drive the form and content of the presentation of MITCH's information. How users want this information displayed on their personal interface devices and other input/output systems will influence the IntelSpace's final design. Standardized interface specifications will minimize design changes that might result from unnecessary incompatibilities between users and

MITCH. Not all design changes are bad, however. Developers should aspire to remain responsive to user requirements and “desirements” throughout the acquisition process.

The spacelift architecture discussed in the 2025 paper “Spacelift for 2025” is a linchpin to orbiting the hundreds of SENSATs required to complete the SenseNet. Clearly, the design of SENSATs will be influenced by the evolution of that launch system. This traditional link between launch vehicle and payload warrants close attention and detailed coordination.

**Acquisition Summary**

The following illustration highlights the major points of the proposed acquisition strategy for MITCH (fig. 5-1).



Source: Clipart from Microsoft Clipart Gallery © 1995 with courtesy from Microsoft.

**Figure 5-1. Acquisition Strategy.**

The IntelSpace, SenseNet, and other supporting systems are developed in parallel. Establishing an overarching management organization and essential system standards are two important actions toward that

end. Second, the acquisition strategy allows the IntelSpace, SenseNet, and other supporting systems to ride on the crest of commercial developments. This allows scarce military and government developers to focus on computer software for AI applications and network security. Finally, this acquisition strategy does not culminate in a single, all encompassing delivery. Instead, the road of capabilities is incrementally traveled. System integration is deferred until prototypes and smaller operational systems have proven “Man in the Chair” concepts.

## Conclusion

Intelligence support of the combat command and control (C<sup>2</sup>) function is a key ingredient in creating and maintaining a decisive advantage in battle—knowing not only what the enemy is doing now, but also anticipating what he is likely to do next. Providing that information to the right people at the right time is the challenge Air Force Intelligence faces in designing C<sup>3</sup>I systems and organizations.<sup>9</sup>

Maj Gen Schuyler Bissell, the author of the above quote, sees future warfare for what it is. He is talking about global awareness and information dominance. He is asking for a set of required capabilities that MITCH and the “Man in the Chair” concept can provide by the year 2025.

Will the US rise to meet the challenges of 2025? Will we have unrivaled comprehension of the global battlespace? Will it be the US or our adversaries that most effectively “*follow the enemy situation in order to decide in battle?*”<sup>10</sup> The vision of MITCH, proposed herein, provides the answer. The US must act immediately to preserve its competitive edge—and the freedom it protects.

## Notes

<sup>1</sup> Andrew F. Krepinevich, “The Military-Technical Revolution: A Preliminary Assessment,” in *War Theory*, ed. Air Command and Staff College, War Theory and Campaign Studies Department (Maxwell AFB, Ala.: Academic Year 1996): 166.

<sup>2</sup> Maj Gen Garrison Rapmund, USA, Retired, assessor comment to *2025* white paper briefing, “The ‘Man in the Chair’—Cornerstone of Global Battlespace Dominance,” 7 February 1996.

<sup>3</sup> David A. Patterson, “Microprocessors in 2020,” *Scientific American* 273, no. 3 (September 1995): 51.

<sup>4</sup> John L. Petersen, *The Road to 2025: Profiles for the Future* (Corte Madera, Calif.: Waite Group Press, 1994), 193.

## Notes

<sup>5</sup> Charlene Huang, (1995), "Taiwan to develop mass market neural-network ICs," *Electronics* [Online], 1. Available: ProQuest Online [1996, January 27].

<sup>6</sup> Douglas B. Lenat, "Artificial Intelligence," *Scientific American* 273, no. 3 (September 1995): 62.

<sup>7</sup> Herbert Kaufman, (1994), "The Emergent Kingdom: Machines that think like people," *The Futurist* [Online], 20. Available: ProQuest Online [1996, January 27].

<sup>8</sup> Brig Gen William E. Harmon, USA, and Col Richard Webb, USA, "Evolution and Progress: The All Source Analysis System/Enemy Situation Correlation Element," *SIGNAL* 42, no. 4 (December 1987): 26.

<sup>9</sup> Maj Gen Schuyler Bissell, USAF, and Lt Col Daniel G. Kniola, USAF, "Intelligence for Warfighting," *SIGNAL* 41, no. 1 (September 1986): 48.

<sup>10</sup> Sun Tzu, *The Art of War*, ed. and trans. Samuel B. Griffith (London: Oxford University Press, 1963), 140.

## Appendix A

### Sample Systems

This appendix lists and briefly describes current and near-term systems used for intelligence gathering, processing, and dissemination. This list is not all inclusive.

#### CURRENT SYSTEMS<sup>1</sup>

1. Contingency Theater Automated Planning System (CTAPS) for Air Tasking Order (ATO) preparation and dissemination
2. Constant Source—an automatic associator receiving threat data from national and theater systems via the Tactics and Related Applications (TRAP) broadcast and providing an Electronic Order of Battle
3. Department of Defense Intelligence Information System—supporting “timely” preparation and presentation of intelligence information to military commanders and national-level decision makers
4. Joint Deployable Intelligence Support System (JDISS)—supporting imagery dissemination and providing a backbone for secondary imagery
5. Regional Operations Control Center/Airborne Warning and Control System (ROCC/AWACS) Digital Information Link (TADIL)—providing real-time surveillance and battle management information
6. Joint Situational Awareness System (JSAS)—providing some multi-source fusion products for a limited set of users

#### FUTURE SYSTEMS<sup>2</sup>

1. Joint Worldwide Intelligence Communications System (JWICS)—providing secure, high-speed multimedia network connectivity between and among all levels from National Agencies and Commands to deployed forces
2. Joint Service Imagery Processing System (JSIPS)—a modular, deployable imagery exploitation system with the capability to receive, process, and exploit near real-time

inputs from national and tactical assets and then disseminate imagery and message products to commanders at all levels

### Notes

- <sup>1</sup> HQ ACC/SCX, *C4I Systems Guide*, Langley AFB, Va., 1994.
- <sup>2</sup> Ibid.

## Appendix B

### CLARK Small-Satellite Initiative Technology Areas

This appendix lists 36 technology areas advanced through the CLARK small-satellite initiative.<sup>1</sup>

#### TECHNOLOGY SYNOPSIS CONTENTS

##### Electrical Power Subsystem

1. Non-Dissipative Shunt Control
2. S/W Based Battery Charge Control
3. Amorphous Silicon
4. Multi-Junction GaAs Photovoltaics
5. Thin Cell GaAs Photovoltaics
6. Astro Edge Composite Concentrator Solar Array
7. Solid State Remote Power Controllers for Power Distribution
8. NiH<sub>2</sub> SPV Batteries

##### Command and Data Handling

9. Open Architecture Integrated Avionics
10. 32-bit Processor (RHC3000)
11. 3-D Cube Mass Memory Packaging
12. Plastic Parts/Parts Stacking
13. Radiation Hardened FPGAs
14. 16 Mb DRAM Memory Chips
15. Multi-Functional Serial I/O Bus Memory Mapped to CPU
16. Composite Avionics Housing

##### Attitude Determination and Control Subsystem

17. Mini Star Tracker
18. Fine Horizon Sensor
19. Low Cost Coarse Sun Sensor
20. Star Tracker Attitude Rate Measurement
21. HRG Gyro
22. GPS Attitude Determination
23. Low Cost Reaction Wheels

## Structures

24. Integrated, Multi-Functional Composite Shell
25. Thermally Conductive Composites
26. Composite Post-Potted Inserts
27. Self-Aligning Bond-On Nutplates

## Mechanisms

28. Shape Memory Solar Array Gimbal
29. Shape Memory Retention & Release Device
30. Composite Mechanism Housing
31. Frictionless Flexure Solar Array Hinge

## Instruments

32. Miniaturized MAPS Instrument (micro-MAPS)
33. Onboard Feature Identification
34. Image Data Compression
35. Room Temperature X-Ray Detectors
36. 3-D Imaging of Atmospheric Trace Gases

## Notes

<sup>1</sup> CTA Incorporated (No date). *Clark Technology Synopses*, on-line internet, 12 February 1996, available from HTTP: <http://www.futron.com/clark/clark.clark.html>.



## Appendix C

### MITCH Tasks

The Air Force Institute of Technology (AFIT) is conducting an operational analysis in support of the 2025 study. Accordingly, they are scoring each 2025 white paper for its expected performance against a hierarchy of future tasks. This appendix identifies the tasks appropriate to MITCH and estimates to what level MITCH will perform them.

AFIT's hierarchy of tasks (fig. C-1) stems from the single operational goal of "Air and Space Superiority." This goal is divided into three distinct mission areas: "Awareness," "Reach," and "Power." MITCH falls squarely within the scope of "Awareness."

The mission of "Awareness" is further broken out into the three principle tasks of "Detect," "Understand," and "Direct." Several subtasks and numerous force qualities are subordinate to each of these tasks (fig. C-2). For example, "Understand" divides into the subtasks of "Identify" and "Integrate." The subtask of "Identify" is, in turn, evaluated against the force qualities of "Accurate," "Timely," and "Traceable."

The following tables evaluate how well MITCH satisfies the hierarchy of tasks *at the force quality level*. One table is provided for each of the three tasks supporting the "Awareness" mission. The first three columns of every table identify the *tasks*, *subtasks*, and *force qualities*. The fourth and fifth columns carry the *measurands* and *range*, as defined by AFIT, for every force quality. The sixth column in each table evaluates the *system performance* expected for all force qualities. The evaluations are drawn from explicit discussions in the body of this paper or by reasonable extrapolations of MITCH concepts. The seventh and final column refers the reader to a note that rationalizes the scores given in the system performance column.

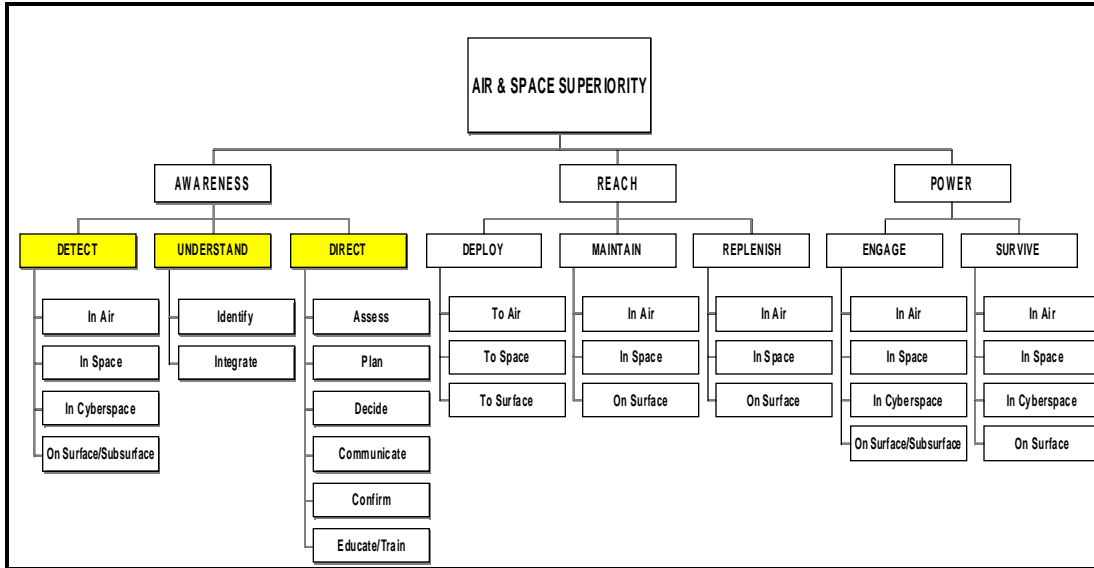


Figure C-1. 2025 Operational Analysis Structure.

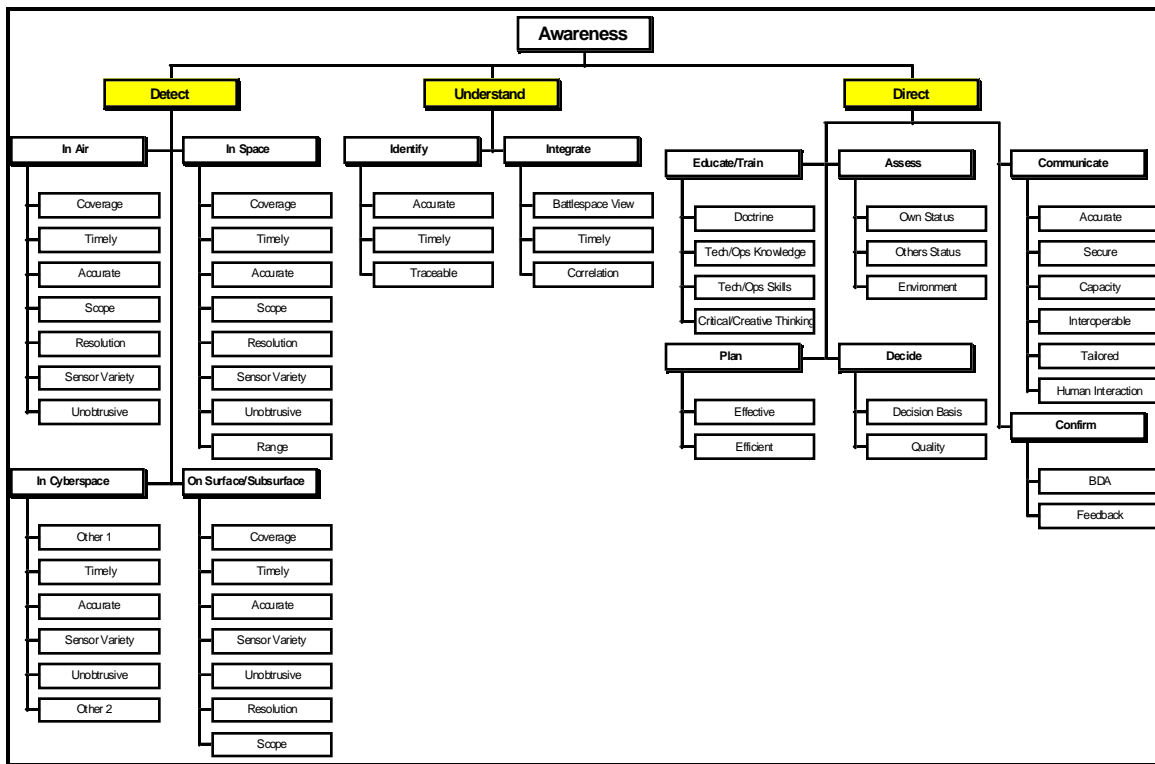


Figure C-2. Force Qualities Supporting the Awareness Mission.

**Table 1**

**Analysis: The “Detect” Task**

<b>Task</b>	<b>Subtask</b>	<b>Force Quality</b>	<b>Measurand</b>	<b>Range</b>	<b>System Performance</b>	<b>Note</b>
<b>Detect</b>	Air, Space, Surface/ Subsurface, or Infosphere	Sensor Variety	Spectral Completeness	0 to 5 Sensor Types	Probably More Than 5	1.
		Coverage	% of Earth	0 to 100%	100%	2.
		Timeliness	Revisit Time	0 to 24 Hours	0 (Continuous)	3.
		Unobtrusiveness	Enemy Knowledge of System	Full to None	Near full knowledge of space presence. Less to none for other sensor types.	4.
		Accuracy	Meters	0 to Infinite	Sub-meter, if required.	5.
		Scope	Day/Night Weather	0 to 100%	High (90+%)	6.
		Resolution	% Target Completeness	0 to 100%	100%	7.
		Range	Range	0 to 20 Astronomical Units	Near zero	8.

1. **Sensor Variety.** MITCH provides a spectrally complete set of sensors in space, and it accepts inputs from all sensors in the air, on the ground, or in the infosphere. It is almost certain this range of sensors will exceed the maximum score of five. Thus, as an intelligence fusion system, it should get full marks in all sensor categories.
2. **Coverage.** MITCH maintains two satellites of every sensor type over every spot on the globe. In addition, it receives inputs from other air, land, sea, and human collectors.
3. **Timeliness.** Given instantaneous global coverage of the SenseNet, revisit time is always zero in surveillance mode. In reconnaissance mode (high resolution or high sensitivity), revisit time can be made zero (continuous) with appropriate allocation of resources.
4. **Unobtrusiveness.** While both survivability and resistance to deception/evasion are important force qualities, “unobtrusiveness” is but one approach to achieve them. MITCH scores high in both of these important qualities, even though the enemy may have perfect (“full”) knowledge of our sensor’s existence. It achieves survivability through proliferation of a distributed network of small spaceborne sensors whose survivability is derived from the inherent redundancy and dispersion of such a network. It undermines a target's ability to deceive or evade it through its persistence and spectral completeness.
5. **Accuracy.** MITCH offers the best geopositioning/location accuracy attainable. User accuracy requirements will be variable, but the tightest accuracy requirements are likely to approach one meter for some targeting systems. MITCH will be able to satisfy these requirements.

6. **Scope.** MITCH assures day/night and all-weather availability of sensor data to the 2025 war fighter by using an appropriate sensor mix on orbit. Synthetic Aperture Radar (SAR) imaging, for instance, will provide imagery at night or through clouds. Infrared (IR) sensors provide additional night imaging capability. Other types of sensors, such as COMINT collectors, are inherently available under almost all conditions.
7. **Resolution.** MITCH will provide high-resolution/high-sensitivity sensor collection—on demand, anywhere in the world, all the time.
8. **Range.** Range, measured in astronomical units (AU), is an irrelevant measure for systems surveying the earth’s surface. This force quality applies only to planetary defense systems.

**Table 2**

**Analysis: The “Understand” Task**

<b>Task</b>	<b>Subtask</b>	<b>Force Quality</b>	<b>Measurand</b>	<b>Range</b>	<b>System Performance</b>	<b>Note</b>
<b>Understand</b>	Identify	Timeliness	Time	“Too Late” to “In Advance”	“Just in Time” to a “Little Ahead.”	1.
		Accuracy	% correct IDs	0 to 100 %	High (90+%)	2.
		Traceability	% Traceable	0 to 100%	100%	3.
	Integrate	Timeliness	Time	“Too Late” to “In Advance”	“Just in Time” to a “Little Ahead.”	4.
		Battlespace View	% Relevant Data	0 to 100%	High (90+%)	5.
		Correlation	% Historical Correlation	0 to 100%	High (80+%)	6.

1. **Identification Timeliness.** Identification of cues picked up by the SenseNet will be near instantaneous. This initial identification will be followed immediately by additional tasking to verify and corroborate data.
2. **Identification Accuracy.** MITCH will achieve a very high degree of identification accuracy through the use of high-resolution sensors and by tasking of multiple sensors and sensor types to corroborate initial cues detected by the SenseNet.
3. **Identification Traceability.** When MITCH “comes to a conclusion” or “offers an opinion” to a user, it clearly displays all the evidence (imagery, HUMINT reports, electronic intelligence inputs, etc.) that led MITCH to its conclusion. This allows users to evaluate the soundness of MITCH’s hypotheses.
4. **Integration Timeliness.** MITCH integrates all sensory data and historical evidence necessary to promptly support answers to intelligence questions. It provides its conclusions to a user either “just in time” or slightly ahead of time, giving users time to react to the information.
5. **Battlespace View.** MITCH searches and analyzes all data in the national intelligence system relevant to a user’s particular task. Through this reliable and comprehensive automatic data search, MITCH relieves users of the drudgery of analyzing “mountains” of raw sensory data, freeing them to plan, evaluate, and execute tasks.

6. **Integration Correlation.** MITCH accesses an extensive historical/archival database to answer user inquiries with existing information. Further, it will correlate archived and current sensor data to detect emerging patterns of behavior that should be highlighted or investigated further.

**Table 3**

**Analysis: The “Direct” Task**

Tasks	Subtasks	Force Qualities	Measurands	Range	System Performance	Notes
Direct	Assess	Own Force Status	% Forces Known	0 to 100%	High (90+%)	1.
		Others’ Status	% Assets Known	0 to 100%	High (90+%)	2.
		Environment	% Known	0 to 100%	High (90+%)	3.
	Plan	Effectiveness	Consideration of Goals, Targets, and Priorities	0 to 100%	High (90+%)	4.
		Efficiency	Avoidance of Waste	0 to 100%	High (90+%)	5.
	Decide	Decision Basis	Consideration of Facts, Alternatives, and Uncertainty	0 to 100%	High (90+%)	6.
		Quality	Balance of Speed, Accuracy, and Risk	0 to 100%	High (90+%)	7.
		Communicate	Accuracy	% Accurate Data	0 to 100%	Near 100%
		Security	% Data Protected	0 to 100%	Near 100%	9.
		Capacity	Gb/s	0 to 10,000	Max	10.
		Interoperability	% Relevant	0 to 100%	High (90+%)	11.
		Tailorability	% Tailored	0 to 100%	100%	12.
		Human Interaction	Method	None to Virtual Reality	Full Range	13.
	Confirm	Bomb Damage Assessment	% Accurate	0 to 100%	High (90+%)	14.
		Feedback	Time (Hours)	0 to 24	Near Real Time	15.
	Educate / Train	Doctrine	Level of Learning	Knowledge to Synthesis	Application	16.
		Tech/Ops Knowledge	Relevant Mil. Knowledge	0 to 100%	High (90+%)	17.
		Tech/Ops Skills	Relevant Mil. Skills	0 to 100%	Moderate (<50%)	18.
		Critical/Creative Thinking	Level of Learning	Knowledge to Synthesis	Synthesis	19.

1. **Assess Own Forces Status.** Since MITCH exercises global surveillance and reconnaissance, it is fully able to provide the status of friendly forces and resources. Further, it could be used to assess friendly capability relative to enemy capability, providing that assessment to commanders at all levels of operations.
2. **Assess Others’ Asset Status.** This is MITCH’s greatest strength—the ability to assess the enemy status, capability, and intent. MITCH achieves this through its extensive sensor network and historical data base.

3. **Assess Environment.** Since MITCH has access to all sensor data worldwide (including weather data, trafficability data, geodesy data, etc.), it could provide a fused picture of the battlefield environment for commanders at all levels of operations.
4. **Plan Effectiveness.** MITCH centralizes tasking of the SenseNet and all other US sensors according to user priorities. This will maximize the overall collection planning effectiveness for all US sensor systems. Further, MITCH provides a single repository of target information for all 2025 warriors to refer to in developing their plans. This maximizes the planning effectiveness of *users* at all levels of operations.
5. **Plan Efficiency.** MITCH's resource allocation decisions will balance collection requirements for intelligence problems at all levels of operations. This leads to extremely efficient resource management. Since it also frees humans from the mundane task of collection planning, users become more efficient in their other tasks, as well.
6. **Decision Basis.** MITCH's hypotheses, and hence user decision making, is well supported by robust historical archives and current collections. In addition, MITCH constantly allocates specific sensors against specific intelligence problems. Where requirements conflict, MITCH works to prioritize collections. It also makes decisions about who to "push" information to, and in what format that data should be presented. MITCH will make these decisions according to a holistic view achieved by virtue of its access to users and sensors at all levels.
7. **Decision Quality.** MITCH balances speed, accuracy, and risk in providing data to users. In addition, the quality of MITCH's decisions will be very high, improving over time with feedback.
8. **Communication Accuracy.** MITCH assumes the availability of reliable and redundant communication channels to its user interfaces. MITCH's nature as a distributed network ensures this.
9. **Communication Security.** Encryption schemes and protected downlinks will make SENSAT communications very secure. MITCH's IntelSpace is secured at the entry points via a robust mix of user authorization verification methods to limit the possibility of system breaches. It includes multilevel security practices to limit damage of any potential breaches.
10. **Communication Capacity.** The SenseNet contains state-of-the-art laser communications for satellite-to-satellite linking of sensor data. These will be among the best available in 2025. Considering just the raw sensor data rate puts SenseNet capacity at 5,000 Gb/s (40Gb/s per satellite x 125 satellites = 5,000 Gb/s). All other communications, including human-to-machine communications, will be supported via commercial or military systems external to MITCH. As a distributed architecture, MITCH will use whatever communication paths are available. Arguably, if MITCH passes data across all these paths, it will far exceed the maximum measurement of 10,000 Gb/s.
11. **Communication Interoperability.** MITCH will be interoperable with all communications media, supporting the key operational concept of Global "PlugIn Play."
12. **Communication Tailorability.** Tailorability is a central theme of MITCH and is reflected in the system's commitment to disseminate the "right product." This capability is provided through software user agents.
13. **Communication Human Interaction.** Human interaction is central to MITCH's capability. MITCH learns what users want and need through daily feedback. This interaction results in user-friendly products. MITCH can support whatever communications medium is fielded—from keyboards to virtual reality displays.

14. **Confirmation BDA.** Battle Damage Assessment (BDA) is a key component of “knowing the enemy situation,” and MITCH is the obvious system of choice for this task. It has access to all sensor data and the ability to assess it. BDA accuracy should be near 100 percent.
15. **Confirmation Feedback.** Feedback is provided to users as requested through their agents. Any information a user needs about friendly or enemy performance is readily available in MITCH on a near-real-time basis.
16. **Educate/Train in Doctrine.** MITCH will provide a fairly robust doctrine training tool since it reflects the doctrine used to train it. As senior leaders formulate and input doctrinal approaches into MITCH, they will themselves be sharpened in the application of doctrine.
17. **Train in Technical/Ops Knowledge.** MITCH will be a rich training resource for military knowledge, since its databases will hold much of the relevant military information available. This data will be presentable to users in any desired format or context.
18. **Train in Technical/Ops Skills.** Use of MITCH will be an important skill for users at all levels of operations. The acquisition strategy inherently trains users to use MITCH and integrates MITCH into US operations through incremental prototyping.
19. **Educate in Critical/Creative Thinking.** MITCH will train its users in critical thinking by developing hypotheses new to the users that task the system. By its very nature, MITCH will “think” in a structured and critical way and will train users in the same way of thinking.

## *Bibliography*

- 2025 Concept. No. 200059. "Automated & Integrated Intelligence Seamless Fusion & Correlation System." 2025 Concepts Database. (Maxwell AFB, Ala.: Air War College/2025, 1996).
- Ackerman, Robert K. "When Words Fail, Data Base Themes Prevail." *SIGNAL* 50, no. 7 (March 1996): 51–53.
- ACSC Technology Division and the War/Theater Level Studies Department. "The O-O-D-A Loop" Toolbook. Maxwell AFB, Ala.
- AFP 200-18. *Target Intelligence Handbook Unclassified Targeting Principles*, vol. 1. 1 October 1990.
- Asker, James R. "Space, Key to U.S. Defense." *Aviation Week & Space Technology* 138, no. 18 (3 May 1993): 51–53.
- Bissell, Schuyler, Maj Gen, USAF, and Lt Col Daniel G. Kniola, USAF. "Intelligence for Warfighting." *SIGNAL* 41, no. 1 (September 1986): 48–51.
- Boyd, John R. "A Discourse on Winning and Losing." Paper presented at Air University for CSAF's 2025 project, Maxwell AFB, Ala. 27 September 1995.
- Braunberg, Andrew C. "Data Warehouses Migrate Toward World Wide Web." *SIGNAL* 50, no. 6 (February 1996): 35–37.
- Brown, Carol E., James Coakley, and Mary Ellen Phillips. "Neural Networks: Nuts and Bolts." *Management Accounting (USA)* 76, no. 11 (May 1995): 54–55.
- Campen, Alan D. contributing ed., *The First Information War*. Fairfax, Va.: AFCEA International Press, 1992.
- Chan, Vincent W. S. "All-Optical Networks." *Scientific American* 273, no. 3 (September 1995): 56–59.
- Clausewitz, Carl von. *On War*. Edited and translated by Michael Howard and Peter Paret. Princeton, N. J.: Princeton University Press, 1976.
- Colodney, Maj Lori. "Getting Command and Control System Back into the Fight on the Digitized Battlefield." Fort Leavenworth, Kans., 17 December 1994.
- Cortese, Amy with John Verity, Kathy Rebello, and Rob Hof. "The Software Revolution." *Business Week*, no. 3453 (4 December 1995): 78–90.
- CTA Incorporated (No date). *Clark Technology Synopses* [Online]. Available HTTP: <http://www.futron.com/clark/clark.clark.html> [1996, February 12].
- Da Silva Curiel, R. A. (No date). *Satellites in the making . . .* [Online]. Available HTTP: <http://www.ee.surrey.ac.uk/CSER/UOSAT/SSHP/future.html> [1996, February 12].
- . (No date). *The Small Satellite Home Page* [Online]. Available HTTP: <http://www.ee.surrey.ac.uk/CSER/UOSAT/SSHP/sshp.html> [1996, February 12].
- Department of the Army. *Army Focus 94, Force XXI*. September 1994.
- Dibbell, Julian. "The Race to Build Intelligent Machines." *Time* 147, no. 13 (25 March 1996): 56–58.
- Gande, William. "Smallsats Come of Age?" *Ad Astra* 6, no. 6 (November/December 1994): 22.
- Gertz, Bill. "The Air Force and Missile Defense." *Air Force Magazine* 79, no. 2, (February 1996): 72–74.



- Harmon, Brig Gen William E., USA, and Col Richard Webb, USA. "Evolution and Progress: The All Source Analysis System/Enemy Situation Correlation Element." *SIGNAL* 42, no. 4 (December 1987): 25–30.
- HQ ACC/SCX. *C<sup>4</sup>I Systems Guide*. Langley AFB, Va., 1994.
- Huang, Charlene. (1995). "Taiwan to develop mass market neural-network ICs." *Electronics* [Online], 1. Available: ProQuest Online [1996, January 27].
- Kaufman, Herbert. (1994). "The Emergent Kingdom: Machines that think like people." *The Futurist* [Online], 20. Available: ProQuest Online [1996, January 27].
- Kosko, Bart. *Fuzzy Thinking*. New York: Hyperion, 1993.
- Krepinevich, Andrew F. "The Military-Technical Revolution: A Preliminary Assessment," in *War Theory*. ed. Air Command and Staff College, War Theory and Campaign Studies Department. (Maxwell AFB, Ala.: Academic Year 1996): 163–98.
- Lawlor, Maryann. "Learning Computers Complement Teaching, Planning, Testing." *SIGNAL* 50, no. 7 (March 1996): 54–56.
- Lenat, Douglas B. "Artificial Intelligence." *Scientific American*, no. 273 (September 1995): 62–64.
- Levine, John R. and Carol Baroudi. *The Internet For Dummies*. 2d ed. Foster City, Calif.: IDG Books Worldwide, Inc., 1994.
- Maes, Pattie. (1994). "Agents that Reduce Work and Information Overload." *Association for Computing Machinery. Communications of the ACM* [Online], 30. Available: ProQuest Online [1996, January 27].
- McNeill, Daniel and Paul Freiburger. *Fuzzy Logic: The Revolutionary Computer Technology That is Changing Our World*. New York: Simon & Schuster, 1994.
- Munakata, Toshinori. (1994). "Commercial and Industrial AI." *Association for Computing Machinery, Communications of the ACM* [Online], 23. Available: ProQuest Online [1996, January 27].
- Negroponte, Nicholas. *Being Digital*. New York: Vintage Books, 1995.
- Owens, Adm William A. "The Emerging System of Systems." *US Naval Proceedings* 121, May 1995 36–39.
- Patterson, David A. "Microprocessors in 2020." *Scientific American* 273, no. 3 (September 1995): 48–51.
- Petersen, John L. *The Road to 2015: Profiles of the Future*. Corte Madera, Calif.: Waite Group Press, 1994.
- Robinson, Clarence A., Jr. "Holographic Storage Media Could Eclipse Optical Disks." *SIGNAL* 50, no. 6 (February 1996): 31–33.
- . "Powerful Battlefield Forces Exploit Space-Based Access." *SIGNAL* 50, no. 7 (March 1996): 33–35.
- Scott, William B. "Russia Pitches Common Early Warning Network." *Aviation Week & Space Technology* 142, no. 2 (9 January 1995): 46–47.
- SPACECAST 2020. Air University. "Leveraging the Infosphere: Surveillance and Reconnaissance in 2020." AU study. 22 June 1994.
- Sun Tzu. *The Art of War*. ed. and trans. Samuel B. Griffith. London: Oxford University Press, 1963.
- Thompson, Suzanne J. (No date). *Mass Storage Technologies* [Online]. Available HTTP: [http://www.nml.org/publications/NML\\_TR/task4\\_final/9\\_mass\\_storage.html](http://www.nml.org/publications/NML_TR/task4_final/9_mass_storage.html) [14 Feb 96].
- Toffler, Alvin and Heidi. *War and Anti-War*. New York: Warner Books Inc., 1993.
- USAF Scientific Advisory Board. *New World Vistas: Air and Space Power for the 21<sup>st</sup> Century*, Summary Volume. Washington, D.C.: USAF Scientific Advisory Board, 15 December 1995.

- Van Creveld, Martin. *The Transformation of War*. New York: The Free Press, 1991.
- Verity, John. "Meet Java, the Invisible Computer." *Business Week* 3452, no. 1 (4 December 1995): 82–83.
- Widrow, Bernard, David E. Rumelhart, and Michael A. Lehr. "Neural Networks: Applications in Industry, Business and Science." *Communications of the ACM* 37, no. 3 (March 1994): 93–105.
- Wright, Robert. "Can Machines Think?" *Time* 147, no. 13 (25 March 1996): 50–56.

# Brilliant Warrior



A Research Paper  
Presented To

Air Force **2025**

by

Jay W. Kelley  
Lt Gen, USAF

August 1996

## **Disclaimer**

**2025** is a study designed to comply with a directive from the chief of staff of the Air Force to examine the concepts, capabilities, and technologies the United States will require to remain the dominant air and space force in the future. Presented on 17 June 1996, this report was produced in the Department of Defense school environment of academic freedom and in the interest of advancing concepts related to national defense. The views expressed in this report are those of the authors and do not reflect the official policy or position of the United States Air Force, Department of Defense, or the United States government.

This report contains fictional representations of future situations/scenarios. Any similarities to real people or events, other than those specifically cited, are unintentional and are for purposes of illustration only.

This publication has been reviewed by security and policy review authorities, is unclassified, and is cleared for public release.

## *Contents*

	<i>Page</i>
Disclaimer.....	ii
Introduction.....	1
Training and Education.....	1
The Quest and the Questions.....	2
Alternate Futures.....	2
Unions and Intersections.....	3
The Environment.....	4
The Output.....	6
The Input.....	7
The Thirteenth Generation.....	7
Forming Brilliant Warriors.....	9
General Characteristics of a Future PME System.....	9
Specific Characteristics of a Future PME System.....	10
Choosing Wisely.....	13

## *Illustrations*

<i>Figure</i>	<i>Page</i>
1. The Brilliant Warrior Model.....	13

## Introduction

*If we should have to fight, we should be prepared to do so from the neck up, instead of from the neck down.*

—Jimmy Doolittle

Centuries ago Confucius observed that to lead an uninstructed people to war is to throw them away.” Today, centuries later, there can be no doubt that professional military education (PME) is a critical complement to professional military training. To assert that education is more important than training, or that training is more important than education, is to engage in an argument ultimately without much merit. Fielding an untrained armed force would be as unconscionable or as stupid as fielding a trained one led by uneducated *or* untrained leaders. While all agree on the importance of both training and education to the armed forces of the future, there is plenty of room for debate on how much professional military education a warrior needs, the different forms it ought to take, and the timing and the impact of information technologies.

This article hopes to encourage, and even enliven, that debate.<sup>1</sup> One thing is not debatable: People are the most valuable and critical element in the armed forces. It is people who must fight and win our nation’s wars. Technology provides the tools for fighting, and *training* enables us to use those tools to their best advantage. The aim of professional military *education* is to leverage the most powerful factor in the war-fighting equation: the human mind. Our training institutions and the capabilities they provide are superior. Training has remained relevant and has repeatedly reengineered itself to take advantage of advances in information technology, simulation, and discoveries about how adults learn best. Training is challenging, experiential, and, in some ways, fun. PME, on the other hand, has not kept pace with the improvements in training, let alone the need.

Unless PME better prepares warriors for the demands of the future, even our best training may be wasted. Understanding the changes that need to be made in the future of PME requires first that we differentiate between professional military training and professional military education.<sup>2</sup>

## Training and Education

Military training and education do not aim at providing jobs or adventures. They are necessary for success in warfare. Training creates competence in using the machines or tools required for current military tasks. It is about teaching others things we already know and about using things that operate mechanically, electrically, or more or less predictably. Education, on the other hand, aims at acquiring the right intellectual

constructs and learning the appropriate principles of selection so that the needed tools are available and the right ones can be selected and used to achieve a desired effect. It is about trying to learn whatever it is we do *not* know but that *we envision what we need to know* to survive and succeed. Said another way, training teaches the archer how to use the bow and arrow. Education insures that the archer not only knows how and when to use the bow—and always aims the right arrow at the right bullseye—but also immediately sees the value of gunpowder as an improvement and complement to archery. The test of training is demonstrated competence in environments that exist and are understood today. The test of education is success in different environments; those perhaps not fully understood today, and those that may exist in the future.

### **The Quest and the Questions**

For the past several years, Air University has engaged in studies of the future. SPACECAST 2020 was followed by the current effort, **Air Force 2025**, which was directed by Gen Ronald R. Fogleman, the Air Force chief of staff. This study aims to understand the air and space capabilities our country will need in the future, the systems and technologies that might contribute to those capabilities, and the concepts of operations needed to employ new capabilities best. Closely related in objectives are the numerous studies and seminar wargames being sponsored by the Office of the Secretary of Defense which seek to understand the revolution in military affairs (RMA). Each of the services and the joint staff are looking into the future. The quest is to look ahead two or three decades to understand the future “operating environments” in which our armed forces might find themselves. The obvious initial questions that arise are “Which future?” and “What makes you think you’ve got it right?”

### **Alternate Futures**

Moving into the future, my friend Carl Builder reminds me, is like driving into the fog.<sup>3</sup> If one wants to see specific things in the fog, turning on the high beams only illuminates the fog more brightly. To see the shapes in the fog requires lowering your beams, peripheral vision, and the ability to see the relationships between the shapes, the road ahead, and the means of illumination. It also requires making implicit assumptions explicit and then challenging them. The first thing one “sees” using Builder’s image is that there is more than one future visible in the fog. These “alternate futures” are each different, internally consistent, and often equally plausible. Any one of them could become *the* future. Some are benign. Others are onerous. Taken together, these alternate futures bound the strategic planning space, help identify risks, and offer awareness of the different challenges and opportunities that *may* lie ahead. Alternate futures are descriptive, not predictive or normative. They are “planning stories” or “scenarios.” Aware of alternatives, planners can choose to reject or ignore any or all. The objective is to clarify the shapes in the fog to reduce surprise and, hence, risk for decision makers. After all, the decision maker might be *you*.

But how do we know we got it “precisely right” in these planning scenarios? Alternate futures aim not to be precisely right but merely plausible and approximately right. This position is preferable to stumbling blindly ahead, or tenaciously clinging to the present until it unexpectedly becomes a future for which we are ill-prepared. The process of generating alternate futures, while necessarily a creative process, is rigorous and methodical. Just as we know the past by inference, we gain insight into futures by the same process of inferential reasoning. We also know that competitive, for-profit businesses generate alternate futures at considerable expense and can show that profitability increases when planning looks far ahead. A business that fails to look ahead may miss a new market or lose market share. Armed forces that fail to look ahead can lose the nation.

We look ahead to avoid being surprised, and there are other methods of looking ahead besides alternative futures.<sup>4</sup> Methodologies may vary, and some are better than others, but all have a common objective: to provide insights into tomorrow so that present behavior can prepare us to cope with future demands.<sup>5</sup> Thus, the task is to look ahead, describe the operating environment, describe the coping skills this environment may demand, and then postulate a range of actions in the present likely to produce the desired results in the future.<sup>6</sup>

## **Unions and Intersections**

We are beginning to learn some things common to all futures: simply put, the soldiers, sailors, airmen, and Marines of 2020 or 2025 must become as “brilliant” as the tools they might have at their disposal. For example, the Marines’ *Sea Dragon* and the Army’s mobile digitized *Force XXI*—or whatever those become en route to the far future—cannot be understood or prosecuted by any but thoroughly trained and exquisitely educated forces. Add to this the growing possibility that engagement in nontraditional military missions is likely to increase, and that the armed forces are not likely to increase in size, then one begins to see that the education and training challenges are immense. A few examples illuminate the challenge.

What should planners study to enable them to envision a strike with precision-guided munitions against 5,000 targets simultaneously to produce the desired strategic effects? What kind of education is required to prepare a future combatant to go directly from an embarkation point in the continental United States (CONUS) to link up with a friendly coalition force to fight a common adversary in less than 12 hours after leaving home? How, for example, does one “train” a Marine for firefighting in California one week and, the next month, expect him or her to survive a firefight of the more hostile kind in combat with a uniformed enemy?

Recognizing the magnitude of these kinds of challenges—and continuing the quest to keep PME vital begun by Rep Ike Skelton—the DOD’s Office of Net Assessment has



sponsored workshops and conferences focusing on the military training and PME challenges posed by the future and by the RMA. In the conference reports, summary essays, and commentaries, similar themes begin to emerge. Whatever the actual future, there are useful unions and intersections in the environment of all futures. Armed with this awareness, we can chart or propose the waypoints leading to the future.

## **The Environment**

An examination of future studies indicates that the operating environment of the far future probably will have at least these five attributes important to those planning today's professional military education and training.<sup>7</sup>

*First, humans will still fight, and fighting could occur from anywhere on the planet's surface up to and including cislunar space.* Much will change between now and the far future, but it is foolhardy to expect human nature to change in one generation to the degree that there is no likelihood of organized conflict. Someone will always want the other guy's "stuff." The fights, when they occur, could occur in environments ranging from jungle to polar ice to city to the orbital heights. The fights could be with national armies, criminals, or irregulars. The state will not wither away, even though it may have more powerful competitors than what we have today.

*Second, the US armed forces will have become smaller; capability will be more tightly integrated; and speed, precision, and the ability to operate effectively in ambiguous circumstances will become the treasured operational values.* "Cost" will be as important a criterion as capability in organizing, training, and equipping this future force.<sup>8</sup> A cadre of nearly transcendent professionals—but not *six-million dollar men* or *robocops*—will constitute the force. The services probably will not merge into one service, nor are we likely to create a space corps or an information corps. We will still need a means to develop experts in land warfare, naval warfare, and air and space warfare—including the information operations that cross-cut all those combat media. This force will work side-by-side with many contracted and interagency personnel. All members of this force of the future must understand their individual contributions to the whole and how the contributors are integrated to meet the objective. Knowing how to make "my part" of the force work right won't be good enough; I must know how "your part" works, too.

The gold standard for this force will be its ability to make rapid precision strikes, both physical and electronic-photonic, and operate effectively in situations that may have high ambiguity. Precision and engagement speed (strikes and restrikes) will compensate for smaller forces. Events will unfold so rapidly that time and timing become critical. The ability to act over great distances, to achieve desired strategic effects rapidly with a minimum amount of damage (including

damage to the ecosystem) or casualties, and to withdraw or terminate quickly may well deter many potential adversaries.

Third, *there will be swarms of interactive smart machines*. Builder called the information technology explosion “the key disturber” of our time.<sup>9</sup> “Brilliant” systems—with many of them being quite small—are the inevitable consequence of the explosion in computing power and information technologies. A lecturer at Air University suggested that there could be microchips in just about everything before the middle of the next century. These little microchips would make “dumb” things smarter. When the microchips communicate with a central processing unit, they will constitute a “smart” network. When smart networks communicate, almost brain-like systems will emerge. Today, retired Adm William Owens and others describe this phenomenon as the coming “system of systems.” In 30 years so much “intelligence” will have been embedded in everything, with so many of these things interacting with humans, that we are more likely to describe the armed forces of the future as an “organism of organisms.”

Fourth, *coalitions will be the norm*. Technology and a common dedication to improving human quality of life will combine effectively to shrink the planet and lead to a greater harmonization of interests, without a loss of cultural or national identity. The electronic internetting of economies, the tremendous increase in routine leisure and business travel, and the ease of person-to-person contacts will facilitate greater cooperation. Threats to the interests of one of our global partners will imperil us and other global partners more than they do today, and we will act in concert with our partners. Military-to-military exchanges, coalition training exercises, and actual operations will link the allied warriors of the planet and promote a kindred spirit among them. We must and will preserve the ability to act unilaterally, but—like it or not—coalition operations will be the norm.

Fifth, *tomorrow’s subordinates and leaders will be different from today’s*. While this conclusion may have the ring of the authentically unremarkable to it, we tend to forget that people in the distant future will not be exactly the same as 1995 people propelled unchanged into the future. The same genetic material will be influenced by a vastly different environment. Some analysts observe that often ignored social changes may be the driving force of all change, including changes in technology. Thus, we need to remain aware that the “led” of the far future will be conditioned by events and forces en route to the future that we cannot foresee today. By the first part of the next century, they may appear as different from our perspective as the leaders and led of 1965 seem when we recall them today. While you and I may appreciate other music, tomorrow’s *leaders* seem to prefer MTV, *Hootie and the Blowfish*, and *Snoop Doggie Dogg*. We can only imagine what *their* subordinates will favor.

Our leaders will change, too. By 2025 we will have had nearly half a century of jointness in the US armed forces and the speed bumps of today will have been flattened.

The demographic composition of the Congress also will be different. Today, fewer than 40 percent of the Congress have served in the armed forces. Thirty years from now the percentage may be much smaller. An important element of continuity is that our armed forces will remain respectful of the president, beholden to the law, including all the laws made by different Congresses between now and the far future, and will remain under tight civilian control.

## The Output

Given the five likely attributes of the future environment, to complete our model we must next examine the desired output as a prelude to describing the input and the military education and training contribution. To cope and succeed in a world with the attributes postulated, what kinds of skills and behaviors are required? In the most compressed terms possible, and given the attributes of the future environment, education must help military professionals *at least* acquire this kind of knowledge, learn these skills, and have these behaviors:

1. *A constantly improving understanding of human motivation and the interpersonal skills necessary to achieve cooperation to attain the desired objective or achieve the desired effect.* In other words, the essence of leadership may be the ability to act with an understanding of what makes people tick. Harry S. Truman defined leadership as “making people do what they don’t want to do and like it.” Understanding why humans of different backgrounds and cultures (or services) behave the way they do in different circumstances is integral to understanding the sources and nature of human cooperation, friction, and conflict. To prepare military professionals for success in the far future, they must learn more about leadership and human behavior—their own, their subordinates’, and their adversaries’.

2. *A strong commitment to right conduct that almost invariably results in right behavior.* Note the qualifier “almost.” Because human nature will not change much, and because freedom to choose is important, there *will be* misconduct and mistakes in spite of our best efforts to prevent them. In 30 years our democracy will be more mature and will have evolved, but it will be based, as it always has been, on our passion for the goodness of individual liberty and our belief that people ought to be respectful of the law. As public servants in a society that cherishes its free press, we will be scrutinized more closely than they are today. A military that loses public support may be in more trouble than one which loses a battle. Education can provide the confident assurance of virtue, right conduct, and the fidelity to core values. Professional military education must impart the values that build character.

3. *The eagerness to discover new tools, the ability to think creatively of new uses for existing tools, the initiative to innovate, and the ability to know and willingness to take acceptable risks.* The tools and machines available for everything, including fighting, could be as numerous in the far future as they are marvelous.<sup>10</sup> Gazing back to

1965 and comparing the technologies available then to those available today, space systems (except for spacelift), stealth, and sensor improvements stand out initially as military innovations. The powerful information technologies and the advances in biochemistry and medicine were developed by the private sector. Even so, the armed forces of 1996-2025 must have the knowledge and the incentives to identify and select those emerging developments that can enable dominant military capability: the basic sciences of chemistry and physics; discoveries and innovations in pharmaceuticals, electronics, air and space industry; and information technology. All of us need to know more about space and space operations because our quality of life and success in battle will depend increasingly on them.

Certainly, the areas of technical competence that *training* must provide are more numerous, but education aims at big constructs acquired in more complicated ways. Knowing the environment and the desired output, what then is the input?

### **The Input**

The president of the United States in 2025 probably is in high school today. The chairman of the Joint Chiefs of Staff and the chiefs of staff of America's services of the far future are cadets, midshipmen, lieutenants, or captains today. The environment and experiences that will have formed them will be significantly different from the experiences that formed today's warriors. Thus, we begin with a different input: somewhat different people with a somewhat different orientation.

### **The Thirteenth Generation**

The differences in this generation are significant.<sup>11</sup> The present generation is the first generation to have grown up with television and matured with computers, video games, and portable communications devices. Most are "wired," and "the net" is just another "really cool" place. They are fitter and healthier than we are, and their offspring likely will be even healthier. They are destined to live longer. They "recycle" because it's obvious to them—"like get a *clue*, dad"—that humans *ought to* care for the planet and the environment. They have experienced more (and earlier) than past generations. They want "more" and are willing to take risks to get more. They are enthusiastic and impatient. They demand stimulation, excitement, and speed in their lives. Many are in family situations with a single parent, multiple step-parents, or absentee parents. They are loyal fans of people and teams and brand names. They expect and demand diversity. They are choosy, and some are private and protective of their "stuff" and their "space." Most are good people, even considering that some are good people in bad circumstances. They will come to us because we offer them challenges and responsibilities they cannot get elsewhere.<sup>12</sup> Thus, the question becomes, "What must we do in PME today and tomorrow to educate folks *like these*—the military leaders of the next century?"

One answer is to ignore their differences and assert that we will force them into the cookie-cutter of our traditional professional military education system; an environment, John Warden once remarked, “Socrates would be comfortable in.” But remember, they will come to our hallowed halls already trained and will expect no less challenge in education than they experienced in training and, for that matter, “at home.” The traditional approach is not likely to work. Rather, PME must come at the right times, offer them the right set of experiences, help them to navigate to the right information in the sea of available information, encourage them to use the nearly risk-free laboratory of the PME university to experiment and innovate, use technology to place them in unusual circumstances and environments, and guide them to make connections and arrive at conclusions they can test for themselves. If we can *envision* alternate futures, we can use technology to create them as virtual realities. If they cannot get all the genuine experiences we believe they will need to survive and succeed, we must strive to give them many *near-genuine* ones. If we can use technology to help them learn to operate in the virtual reality of these alternate futures, we help to prepare them to cope with the demands of whatever “the” future will offer. *The role of the professional military educator in the future is more important, not less important.* Those of us responsible for PME must, in short, prepare each of our charges to be a “Brilliant Warrior.”

Brilliant does not mean “an IQ of over 140” or “SAT scores of at least 1,500.” It means that we have taken people *already committed* to the warrior profession and must train and educated them in such a way that by 2025, as compared to today, they will be brilliant—smart, adept, agile, savvy—professional warriors. Take away the gizmos of Robert Heinlein’s *Starship Trooper* and use that image to envision the best in tomorrow’s warriors. They should have all the attitudes and behaviors that allow them to survive, succeed, and lead others in whatever future we find ourselves. They must be lifelong learners, thinkers, and prudent risk-takers. Our gift to them is a PME system that forces them to think, encourages them to learn how to learn, and gives them the confidence that they will know what to do in new operating environments because we’ve given them the opportunity to *experience* these alternate environments. Their gift to us, in return, is that we can have high confidence that they know how to behave and will not let us down. They are, or will be, the champions of the warrior profession, the guardians of democracy, and the protectors of *our* future.

Recall I asserted that there will be fewer warriors in the future and that cost will rival capability as a criterion for organizing, training, and equipping the force. As alternative approaches to PME are evaluated, the two suggested criteria are (1) effectiveness: the desired knowledge is acquired and the right behavior results; and (2) cost: the highest value and best return on investment results.<sup>13</sup> Both criteria must be applied with an awareness of the changes that will occur *naturally* between now and the far future.<sup>14</sup> The debate has begun; it is now time to enliven it.

## Forming Brilliant Warriors

The alternatives that might meet the specified knowledge and behavioral objectives are many. Choosing from among the alternatives will define *specific* characteristics of a PME system that must *also* choose its *general* characteristics. The process of choosing is itself difficult: today there are public laws to satisfy; the Joint Staff is involved; and the services, training commands, and using commands are all participants in the process. Tomorrow, future strategy reviews, force restructure, roles and missions commissions, and new public laws also can be expected to affect choices.

### General Characteristics of a Future PME System

As the services become more integrated over time and the size of the defense establishment shrinks, efforts will be made to reduce infrastructure costs and investment. Today, each of the services has both a command and staff college *and* a war college. Tomorrow, the services may be represented by robust “departments” on one campus—a move the British are making. Another alternative, of course, would be to combine what are today intermediate- and senior-level schools into one school for each of the services, and transform the National Defense University into general and flag officer PME.<sup>15</sup> Today, a warrior is likely to attend resident PME both at the intermediate level *and* at the senior level, devoting 20 or more months to in-residence education. Tomorrow, resident PME might be for periods of much shorter duration. Today, selection for resident PME is made by the service. Tomorrow, joint selection boards may identify officers to attend resident PME.

Today, PME is technology-poor. Tomorrow, and if the private sector is encouraged, resident PME could have powerful technologies. These technologies would allow creation of different virtual realities and use resident PME as the crucible for learning experiences that may not be duplicated in or provided to the field.<sup>16</sup> For example, we may wish the warrior to experience operating in a known environment, such as Somalia or Bosnia. But we may also want to provide the warrior “the experience” of adapting to a less certain or future environment.

Today, PME is discontinuous and episodic. Tomorrow, resident and nonresident education may see warriors *continuously* educating themselves in a deliberate lifelong learning system. Today, civilians on the faculty of PME institutions may have “tenure.” Tomorrow, they may be contract employees, visiting scholars from civilian institutions, and former warriors who have “been there and done that . . . well.”<sup>17</sup> Today, much of the core of most PME curricula is built around a study of Clausewitz or Mahan and the great campaigns of history. Tomorrow may see curricula built around providing stressful experiences in virtually real leadership situations and in employing joint doctrine and combined arms in coalition war games, along with ethics education, and regional studies. Envisioning, creating, and teaching such a curriculum requires educators of impressive competence.

All of these—and more—choices and challenges, and the debates that will most assuredly attend them, await us. And “us” is all of us: the Congress, special panels and commissions, the Office of the Secretary of Defense, the Joint Staff, the commanders in chief, the services, training and education commands, and the troops. My guess is that those of us responsible for providing PME will remember the tongue-in-cheek challenge of General Rokke’s *Rule Number 5*: “As academies, we will advise others to change, but will likely ensure that revolutionary change takes place most slowly within our own organization.”<sup>18</sup> This will not do. If we do not adapt, innovate, and lead-turn the need, then we are without merit and not fit to lead, let alone educate.

### **Specific Characteristics of a Future PME System**

Even as the choices that determine the general characteristics of a system intending to produce Brilliant Warriors are being made, more specific choices must be made also. The specific elements chosen must, like the general ones, meet some criteria. I proposed effectiveness and cost. The aim is to bring the powerful learning *experiences* of life, leadership, and warfare into PME. It is experience that may remain the best teacher. As Lao Tze argued centuries ago, “If you tell me, I’ll listen. If you show me, I’ll see. If I experience it, I’ll learn.”<sup>19</sup>

The function of PME is to produce effective warriors who behave properly. The form that PME takes is determined by its function, by the environment, and by the characteristics of the people to be educated. Given the behavioral objectives postulated, and recognizing that the specific characteristics of a future PME system will be affected by the choices influencing the general shape of PME, what are the alternatives? I frame these alternatives as questions, and the questions are not intended to be either mutually exclusive or exhaustive. The conclusions reached—my answers—are hypotheses for testing and debate. They include the following:

• **A constantly improving understanding of human motivation and the interpersonal skills necessary to achieve cooperation to attain the desired objective or achieve the desired effect.**

- More psychology, anthropology, or social science?
- Interactive learning with artificial intelligence as a tutor or more classroom teachers?
- Virtual reality systems that allow the student to live in future environments?
- More role-playing, case studies, biography?
- Increased international officer and civilian enrollment?
- More theoretical models to study and evaluate?
- More “virtual” travel or military-to-military exchanges?
- Studies of mathematics and chaos theory?
- Multidisciplinary teaching teams?

—More history or less?

Brilliant Warrior, as I envision it, requires that distance learning keep the force in continuous PME.<sup>20</sup> Yet, even distance learning will be tiered: all learners receive a customized curriculum, and the more eager students receive a more challenging curriculum than the others. While some warriors are nonetheless in PME, they may remain at the “maintenance” level their entire career. Only the top percentage of a year group--those who have demonstrated the potential for future command--will attend resident PME. The foregone conclusions should *not* be that resident PME be nearly one year long, nor that it must occur at traditional sites. This resident PME of the future could be a series of shorter resident-learning opportunities. These learning opportunities aim to provide those experiences that distance learning cannot provide. Chief among these is experiencing living and performing in the stressful circumstances of alternate futures. Thus, resident PME must begin to provide a more experiential curriculum that bears on the problems of conflict, human relations, and military leadership. Knowledge is about making connections and choices, so the approach taken is necessarily multi-disciplinary. Likewise, the course must be multicultural. The participation of international officers and civilians must increase. One series of in-resident learning opportunities might focus air officers on experiencing joint and coalition air and space operations in an alternate future environment. A different series tailored for naval officers would allow them to experience future operations in their operational medium. These PME resident learning opportunities might come several times a year between the 10- and 15-year points—some of them intentionally on short notice—and prepare the warriors for initial large command and senior staff responsibilities. Those exceptionally well qualified, as indicated by selection for general or flag rank, would go on to the National Defense University of the future at just past the 20-year point. These concerns are listed below:

• **A strong commitment to right conduct that almost invariably results in right behavior.**

- More ethics education or less?
- Deeper study into the American system of government?
- A curriculum that requires making difficult personal resource allocation choices?
- Placing students in alternate future environments with high ambiguity and uncertainty?
- More health and fitness activities or less?
- More seminars or fewer seminars or no seminars?
- More or less reading and writing?
- More personal mentoring or less?

Professor Dick Kohn of the University of North Carolina and others express concerns about civil-military relations that demand attention.<sup>21</sup> For America to maintain its leadership position, it must have leaders who understand the American ideal, the way



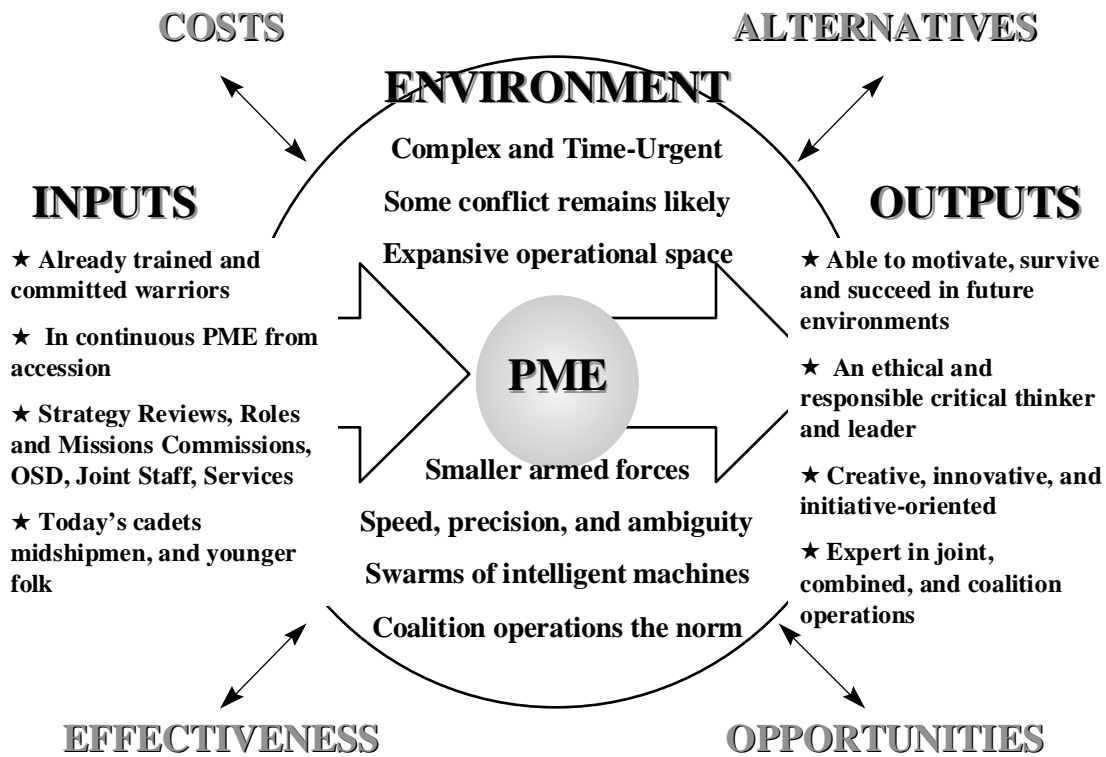
in which the government and its decision-making processes work, and the Constitution. These leaders must also be educated in the service's core values and in ethics. It is on these pillars that distance learning in the five- to ten-year time frame ought to be built, since civilian educational institutions may not emphasize them to the degree *required* for professional warriors. In all cases, resident education needs to broaden awareness of the challenges that may be encountered in the future, and technology could allow the warriors to experience them by performing in virtually real futuristic environments. These concerns include the following:

• **The eagerness to discover new tools, the ability to think creatively of new uses for existing tools, the initiative to innovate, and the ability to know and willingness to take acceptable risks.**

- A wargame-centered curriculum?
- A research-centered curriculum?
- A book-centered curriculum?
- More studies on the relationships between technology and war or less?
- Formal education and experience in creative thinking?
- Formal education in logic, rhetoric, and critical thinking?
- A mandated curriculum or a self-selected curriculum?
- Opportunities to experiment with and fight different force structures?
- Formal education in operations research and operations analysis?
- More emphasis on the sources of conflict and change or less?

Brilliant Warriors must be critical thinkers. Professor I. B. Holley of Duke University identifies the lack of education in critical thinking as a serious shortfall in today's PME curricula. Critical thinking skills are enhanced by a curriculum that emphasizes research. The French currently use a research-centered model in their joint senior PME today. Research into the past may be less germane to the Brilliant Warrior than disciplined and creative thinking about the future, but the value of studying the past is that it warns us about repeating mistakes in the future. More and better wargames (including analytical wargames) need to bolster the resident curriculum to improve critical and creative thinking. Studies of joint forces and capabilities—of the “here's how Joint Operation Planning and Execution System works” or “a battalion looks like this” or “an F-15E does that” variety—which are not “educational,” do not require critical thinking, and today clutter the curricula of even senior PME, would fill the 10-to-15-year interval of continuous distance learning. Readings and interactive discussions in strategy and history, using advanced distance learning, would provide the basic discernment necessary to be a warrior leading warriors. Performance in distance learning courses should be a factor in selection for resident PME.

The illustration below summarizes features of the Brilliant Warrior model.



**Figure 1. The Brilliant Warrior Model**

### Choosing Wisely

Military training and PME are critical components of the national security strategy. Military training and PME thus intersect the interests of three of our most conservative institutions: the military, education, and the government. These institutions are not as averse to change as they are slow to change and quick to resist unnecessary change. We have brilliant educators to help meet the goal of producing Brilliant Warriors for the future, but what we lack is vision—where we want PME to go and what we want PME to be. PME classrooms may be wired and students may be issued laptops, but—without vision—these may be little more than unavoidable, unimaginative, and interesting improvements.

There is no time like the present to begin thinking and debating the changes necessary to keep PME relevant and valuable. The future, whatever it proves to be, will be our measure. Unless we act in the present, thinking about the future becomes so much intellectual arm-waving. We cannot expect to have Brilliant Warriors to face the future unless we begin preparing today. This essay suggested some ways, but these are not the

only ways and they are not *all* the ways.<sup>22</sup> We are not free to dodge the obligation to choose: PME *will* change. That being so, we should choose wisely.

## Notes

<sup>1</sup> The views expressed are ideas. They are not necessarily the officially held views of the Air Force, the Air Education and Training Command, or Air University.

<sup>2</sup> A definition of training provided by I. B. Holley is “to develop proficiency by instruction and practice or drill; training equips one to do repetitive tasks skillfully.” He defines professional military education as a way “to cultivate the mind to make sound decisions in unique situations; education equips one to cope with uncertainty and confusion.” I. B. Holley to Lt Gen Jay W. Kelley, 6 February 1996.

<sup>3</sup> Carl Builder, “Guns or Butter: The Twilight of a Tradeoff?” (May 1994), a presentation to the USAF Air University National Security Forum, Maxwell AFB, Ala. Used with permission.

<sup>4</sup> The National Intelligence Estimates combine linear trends and extrapolations with human judgment. The “footnotes” of formal disagreement provide alternatives for consideration. Some analysts look at future “trends” to predict when specific changes will occur and their probability of occurrence. Alvin and Heidi Toffler shun trends in favor of making judgments about the “second order effects” of changes that combine. *WIRED* magazine published an entire “scenario” issue dedicated to alternate futures. *Scientific American* dedicated its 150th Anniversary issue to an exploration of key technologies in the twenty-first century. Most recently, the Air Force Scientific Advisory Board published an insightful glimpse into the future in *New World Vistas*. And there are useful books—by Adm William Owens, Paul Kennedy, Peter Schwartz, and John Peterson—that aim to illuminate the world of tomorrow.

<sup>5</sup> The best way to anticipate the future may be to work to shape it. By generating alternate futures the organization is better prepared to avoid less desirable ones and pursue a better one.

<sup>6</sup> Richard C. Chilcoat, “The ‘Fourth’ Army War College: Preparing Strategic Leaders for the Next Century,” *Parameters* (Winter 1995-96), 3-17. While there is plenty of information available for strategic planners, much of it needs further analysis and reflection before it can inform decision making in specific areas. Our concern here is military education and training. Maj Gen Dick Chilcoat’s essay does this by using the operating environment of the future and the future Army described in *Force XXI* to closely link the Army’s premier professional military education school and its curriculum to tomorrow’s demands.

<sup>7</sup> These are what I derive from analysis and synthesis, and limited space does not allow me to engage in limitless justification of this list. Others add other technical and operational attributes: coherent and simultaneous operations, asymmetry, the presence of cruise missiles or weapons of mass destruction, information dominance, and others. Rather than categorize the attributes so narrowly, I have described them in broader terms.

<sup>8</sup> Dr Gene McCall, et.al., *New World Vistas: Air and Space Power for the 21st Century* (Summary Volume), December 1995, 4-5.

<sup>9</sup> Builder.

<sup>10</sup> If the tools are “numerous,” the objects themselves could be small because of advances in nano-technology and micro-electromechanical machines. I don’t envision an armed force larger than today’s force.

<sup>11</sup> Col Donald R. Selvage, United States Marine Corps (USMC), “Recruiting the Corps of the 21st Century,” an address presented to the USMC Reserve Officers Association, Chicago, Ill., 16 September 1995. See also Office of the Assistant Secretary of Defense for Force Management, “1994 Youth Attitude Tracking Study.”

<sup>12</sup> The latest USMC recruiting advertisement video offers potential recruits dangerous tests, trials by fire, the chance to combat evil in the form of video-game-like, computer-generated image of an enemy. If the candidate passes these tests, he or she is offered the reward of permanent transformation. It is an approach specifically designed to appeal to the target market and my guess is that it will work.

<sup>13</sup> The precise delineation of cost, value, and return on investment as metrics remains difficult. Because of the difficulty, PME largely has evaded the “green eyeshade” folk. The ultimate metric is victory in our nation’s wars. Thus, we cannot hold up the pre-WWII German *Kriegsakademie* as a model on the one hand and use the metric of victory on the other. Future cost computations might include such variables as the cost of time away from primary duties, relocation and travel costs, and the overall costs of the PME system

(infrastructure, personnel, recurring expenses). Value can be calculated by determining performance at different costs. Return on investment might be the amount of time served in primary duties compared to the amount of time in resident PME.

<sup>14</sup> For example, for us to specify that “PME needs more information technology” is not particularly insightful. PME cannot avoid acquiring more information technology because one cannot forecast an environment where improvements in information technology do not occur naturally. The real issue is to specify the information technologies *for education* that keep pace with need and with the information technologies used in training.

<sup>15</sup> This alternative would send “operators” to the National War College and “acquisition executives” to the Industrial College of the Armed Forces as an alternative to what is today *Capstone*.

<sup>16</sup> Nicholas Negroponte, *Being Digital* (New York: Vintage Books, 1995), 116-28.

<sup>17</sup> Consider that two forces at work are (1) further reductions in the size of the armed forces and (2) increased life expectancies for Americans. Given those two factors, one can easily imagine a large pool of retired and highly qualified commissioned and noncommissioned officers—already receiving some level of retirement income—willing to offer their services as PME faculty members at competitive costs.

<sup>18</sup> *Conference Report: Professional Military Education and the Emerging Revolution in Military Affairs* (SAIC Document Number 95-6956), 22-23 May 1995. Rokke’s Rules: (1) Projecting the future nature of war is more akin to a floating craps game than an exact science; (2) future PME will need to participate in student learning from dust to dust; (3) the major drivers of RMA currently are outside the military; (4) the path to RMA may run through some, all, or none of our respective institutions; (5) as academies, we will advise others to change, but will likely ensure that revolutionary change takes place most slowly within our own organization; (6) Yamamoto and Rommel did as much for the aircraft carrier and combined arms warfare in American military as 20 years of effort at Newport and Leavenworth; (7) to a greater extent than in the past, the RMA train is fueled by engineers and basic scientists ... as apart from social scientists and humanities folks; (8) the information component of the RMA is inherently joint, interdepartmental, and transnational; (9) ultimately, NDU’s role in RMA ... relative to service counterparts ... will be proportional to the extent that planes, ships, and tanks are marginalized; (10) PME jointness, like good Aquavit, is best in moderation and when accompanied by Army, Navy, Marine and Air Force ‘chasers.’ Used with General Rokke’s permission.

<sup>19</sup> Cited in *SPACECAST 2020*, “Professional Military Education (PME) in 2020,” L-26.

<sup>20</sup> The Air Force chief of staff recently mandated a forcewide “mentoring” program. The result will be that the existing gaps in educational experiences will be filled, and every officer in the Air Force will be in continuous education.

<sup>21</sup> Richard H. Kohn, “Out of Control: The Crisis in Civil-Military Relations,” *The National Interest* (Spring 1994), 3-17.

<sup>22</sup> Additional motivation ought to come from awareness that the United States is not the only nation aiming to improve its professional military educational technology. See Wang Jianghuai, “Warfare Simulation: Research and Application in High-Tech Warfare,” 1 December 1995, in Foreign Broadcast Information Service-CHI-96-018, 26 January 1996, 20-21.

**Brilliant Force  
and the  
Expert Architecture that Supports It**



A Research Paper  
Presented To

Air Force **2025**

by

Lt Col David Atzhorn  
Maj Laura DiSilverio  
Maj Kevin Joeckel  
Maj Mark Ware

August 1996

## **Disclaimer**

*2025* is a study designed to comply with a directive from the chief of staff of the Air Force to examine the concepts, capabilities, and technologies the United States will require to remain the dominant air and space force in the future. Presented on 17 June 1996, this report was produced in the Department of Defense school environment of academic freedom and in the interest of advancing concepts related to national defense. The views expressed in this report are those of the authors and do not reflect the official policy or position of the United States Air Force, Department of Defense, or the United States government.

This report contains fictional representations of future situations/scenarios. Any similarities to real people or events, other than those specifically cited, are unintentional and are for purposes of illustration only.

This publication has been reviewed by security and policy review authorities, is unclassified, and is cleared for public release.

## *Contents*

<i>Chapter</i>	<i>Page</i>
Disclaimer.....	ii
Illustrations.....	iv
Tables.....	iv
Executive Summary.....	v
1 Introduction.....	1
2 Required Capability.....	4
Models.....	4
Instructional System Development.....	4
Life Cycle.....	6
Drivers.....	7
Social Structure.....	8
Technology.....	9
Nature of Knowledge/Learning.....	9
Nature of Warfighting.....	11
ET2025 Imperatives.....	11
3 System Description.....	14
Agile Education.....	14
National Knowledge Superhighway.....	17
Academic Centers of Excellence.....	19
Expert Tutor.....	20
Distance Learning.....	24
Hyperlearning.....	27
Enhanced Screening.....	32
4 Concept of Operations.....	36
5 Recommendations.....	40
<i>Appendix</i>	<i>Page</i>
A Technologies and Capabilities Summary.....	44
Bibliography.....	46

## *Illustrations*

<i>Figure</i>		<i>Page</i>
2-1.	Instructional System Development Model .....	5
2-2.	Life-Cycle Model .....	6
2-3.	Drivers .....	8
3-1.	Notional System Model .....	24

## *Tables*

<i>Table</i>		<i>Page</i>
1	Technologies and Capabilities .....	45



## *Executive Summary*

This paper demonstrates that a new military education and training architecture, supported by investments in key technology components, will produce a brilliant force to meet the challenges of 2025.

Several drivers will shape the 2025 environment and foster assumptions from which derive the required capabilities for education and training in 2025 (ET2025). Our engagement in non-traditional missions will increase. Military operations will be highly complex and joint as well as combined. The demand for highly trained people will intensify. The pace of technological progress will increase. Thus, we must produce “brilliant warriors.” To do so, the military must provide continuous (career-long), on-demand learning tailored to the individual, incorporating technologies that optimize the learning environment. This “agile” education and training system will be capable of rapidly changing in concert with the external environment.

The functions and processes of ET2025 will closely resemble today’s system in that air and space forces must still be concerned with the transfer of knowledge, skills, and wisdom from one source to another. What will be different are the methods and architecture used to accomplish that transfer. Although most of the examples in this paper deal with training, the architecture will support either training or education. Education and training will be available to anyone, anytime, anywhere by way of a new architecture consisting of the national knowledge superhighway, academic centers of excellence for curriculum development, and expert tutors (EXTOR)—all personal artificial intelligence agents. The technologies the military must leverage to enable agile learning are artificial intelligence, virtual reality (and its improvements to simulation), and

improvements in computing and communications. In addition, advances in hyperlearning—expanded use of emerging technologies to create a “whole-brain” learning environment—will create air- and spacepower experts in the shortest possible time and at the lowest possible cost. Enhanced screening tools will further reduce costs by training the right people for the right job.

Together, these concepts form the basis for a new education and training architecture: highly efficient and effective education and training, individualized, on demand and just in time—a paradigm to meet the challenge and produce the brilliant force of 2025.

# Chapter 1

## Introduction

Remember Mr Spock from *Star Trek* and his “Vulcan mind meld”? By placing his fingertips on another person’s cranium, Spock could effect the transfer of images, knowledge, data, and memories from his brain to theirs, or vice versa. The transfer was quick, cheap, tailored (Spock could extract only the information he wanted), and permanent, all characteristics which the air and space forces of 2025 could use to measure the efficacy of their own training and education programs. If we look at education and training, at its simplest, as being the transfer of knowledge or skills from one person or source to another, Spock’s Vulcan mind meld could become the paradigm for education and training in 2025, hence ET2025.

Education and training *aren’t* simple, however, and the mind meld won’t serve as the cornerstone of the ET2025 architecture for several reasons: its technologically infeasible, manpower-intensive, and requires the collocation of “teacher” and “student.” Recognizing these inadequacies, though, helps us frame criteria which will support a stronger education and training architecture in the future, regardless of the stresses confronting our forces.

Although air and space missions, structures, and technologies may have changed by 2025, education and training still will be an important (perhaps *more* important) element of successful mission accomplishment. Further, the fundamental interaction of education and training—the

transfer or development of knowledge or skills—will not change. What *will* change, and what we intend to explore in this paper, are the selection processes for identifying personnel for specific education and training programs, the process by which the transfer of knowledge or skills takes place, and the means of evaluating the end result.

The final evaluation of ET2025 will occur on future battlefields. Success in future operations will demand military professionals intellectually and technically prepared to dominate our adversaries across the full continuum of competition. While technology will provide the tools to engage and defeat our adversaries, education will leverage the most powerful factor in the war-winning equation—the human mind. And training will enable military professionals to use those tools to best advantage.<sup>1</sup>

Understanding the process by which we establish this foundation for battlespace dominance requires a definition of the terms. *Education* develops the intellectual capital required for success and prepares us for future success on many fronts. It develops intellectual constructs that enable visionary military leaders to develop the tools essential to future victory and the ability to use them to achieve their desired effect. It also prepares future leaders to respond quickly, accurately, and decisively to unanticipated and ambiguous situations. By at least one definition, the true test of education is success in environments not fully understood or existing today.<sup>2</sup>

If the test of education is success in environments not existing or understood today, the test of training is competence in environments that do exist and are understood today.<sup>3</sup> *Training* develops the physical as well as mental capital—the technical skills of our warriors—necessary to execute highly complex, technically challenging military tasks in the face of a hostile

adversary. It creates competence in using the tools required for military tasks and produces the capability to perform specific military tasks effectively and efficiently.

While education and training differ in outcomes, the process by which we do both, and the tools we use are similar, if not the same. Thus, when referring to the process of training and/or educating, we will use the abbreviation TRED throughout this paper. We look at TRED, at its simplest, as being the transfer of knowledge or skills from one person/source to another. If specifying a particular outcome (knowledge or skills), we will use the terms *education* or *training*, respectively, as defined above.

The year 2025 will resemble 1996 in at least one respect: the outcome of military operations will reflect the education and training of the participants. However, the TRED process *must*, and *will*, be remarkably different. If our nation expects its military forces to wage war successfully in 2025 and to anticipate the requirements for waging war in 2050, we must revolutionize our TRED process. This process—ET2025—must be revolutionary and will have but a single purpose—creating the “brilliant force” capable of dominating the battlespace of 2025.

### Notes

<sup>1</sup> Lt Gen Jay W. Kelley, “Brilliant Warrior” (Unpublished article, Maxwell AFB, Ala.: Air University, 1996), 1.

<sup>2</sup> Ibid., 2.

<sup>3</sup> Ibid.

## **Chapter 2**

### **Required Capability**

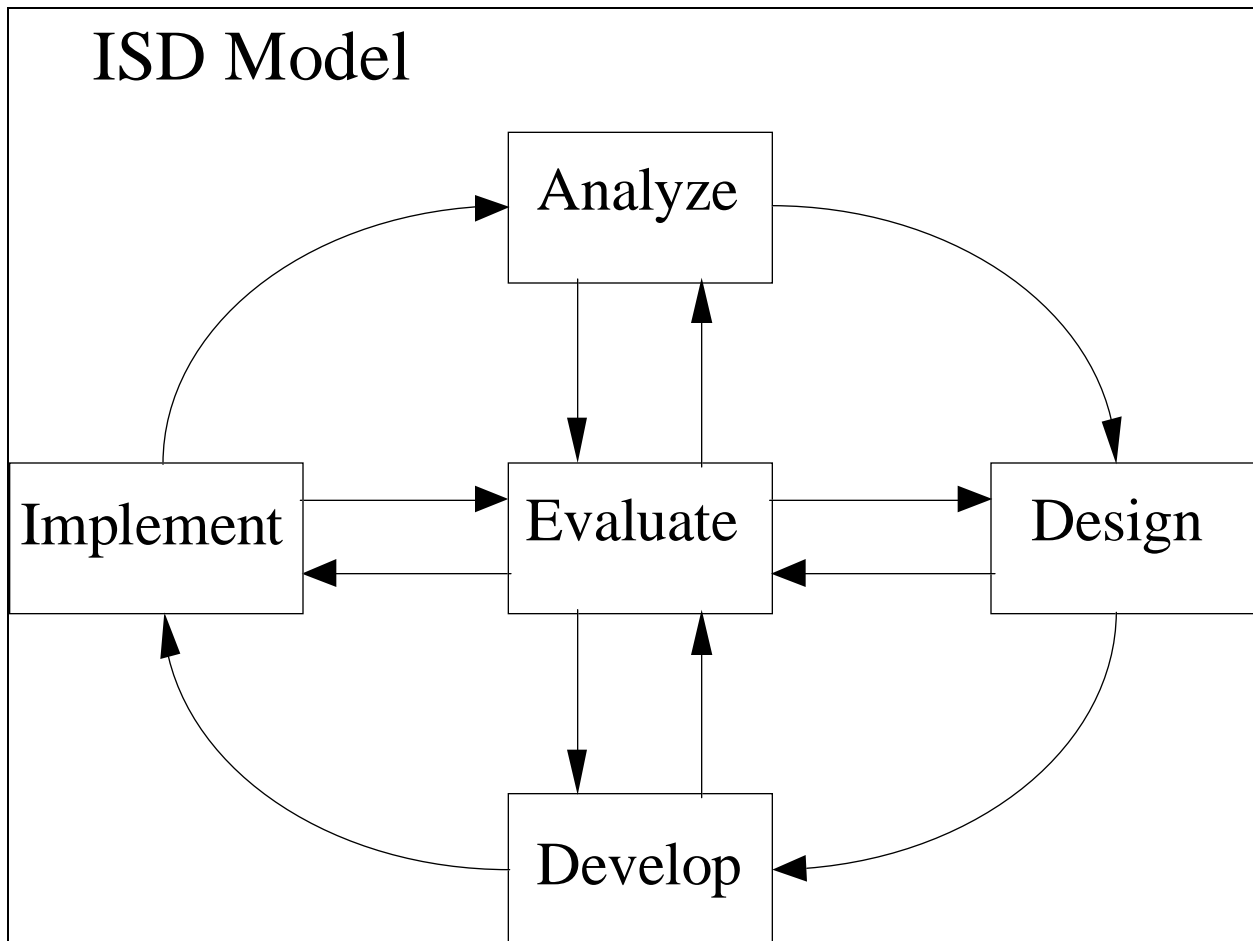
Articulating a coherent vision for 2025 TRED requires a framework for analyzing 2025's TRED imperatives. This paradigm logically will reflect processes for educating and training—or transferring knowledge and skill—and will provide a framework from which we can make useful observations. It will illuminate critical processes internal to the broader “education and training” process, as well as external systems that impact the efficacy of TRED programs. Finally, it must reflect what we know and what is prudent to assume about the future as it will be in 2025. The models that demonstrate the critical processes, together with the drivers that will help define the environment in which it must operate, will illuminate the imperatives for ET2025.

### **Models**

We use the instructional system development (ISD) and life-cycle models to illustrate the significance of education and training for 2025.

#### **Instructional System Development**

The ISD Model represents the process involved in the actual conduct of education and training: it is likely the most popular instructional design model in use today (fig. 2-1).<sup>1</sup>



**Figure 2-1. Instructional System Development Model**

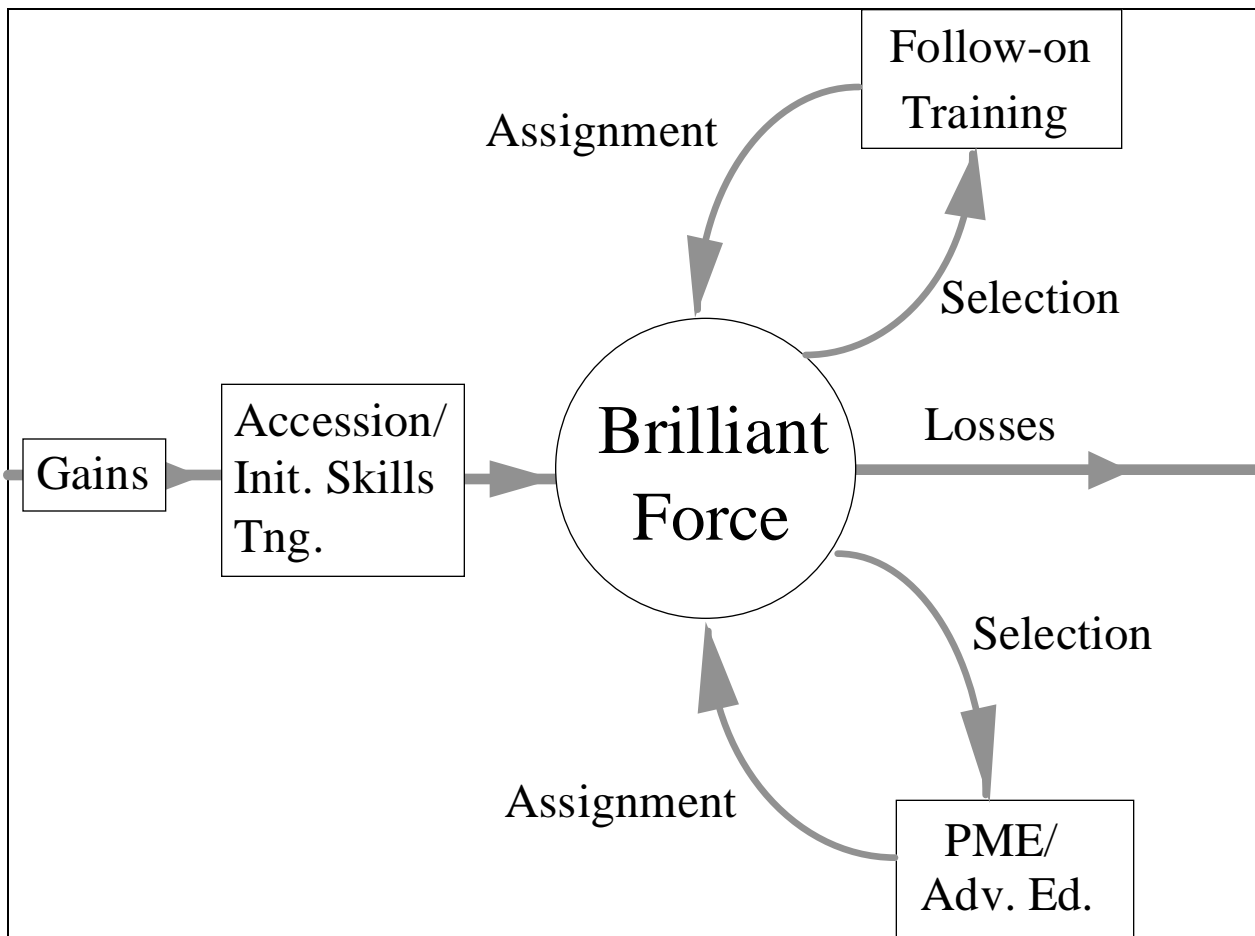
The ISD Model consists of five individual processes: analyzing a “system” to understand it completely, designing a method to achieve the desired outcomes, developing the courseware to achieve the outcomes, implementing the resulting courseware, and then evaluating the development system throughout to validate the process and the results.

This model illuminates the individual processes critical to Air Force TRED programs. The successful military education or training program rests on the capability to develop efficient and effective courseware and the tools to execute that curricula. The ISD Model tells us a successful TRED program requires: an accurate awareness of specific service needs, the specific

knowledge, skills, and aptitudes (KSA) required to execute military operations, and the ability to accurately measure students' KSA before, during, and after training.

### Life Cycle

A generic life-cycle model depicts the cradle-to-grave nature of institutional education and training (fig. 2-2).



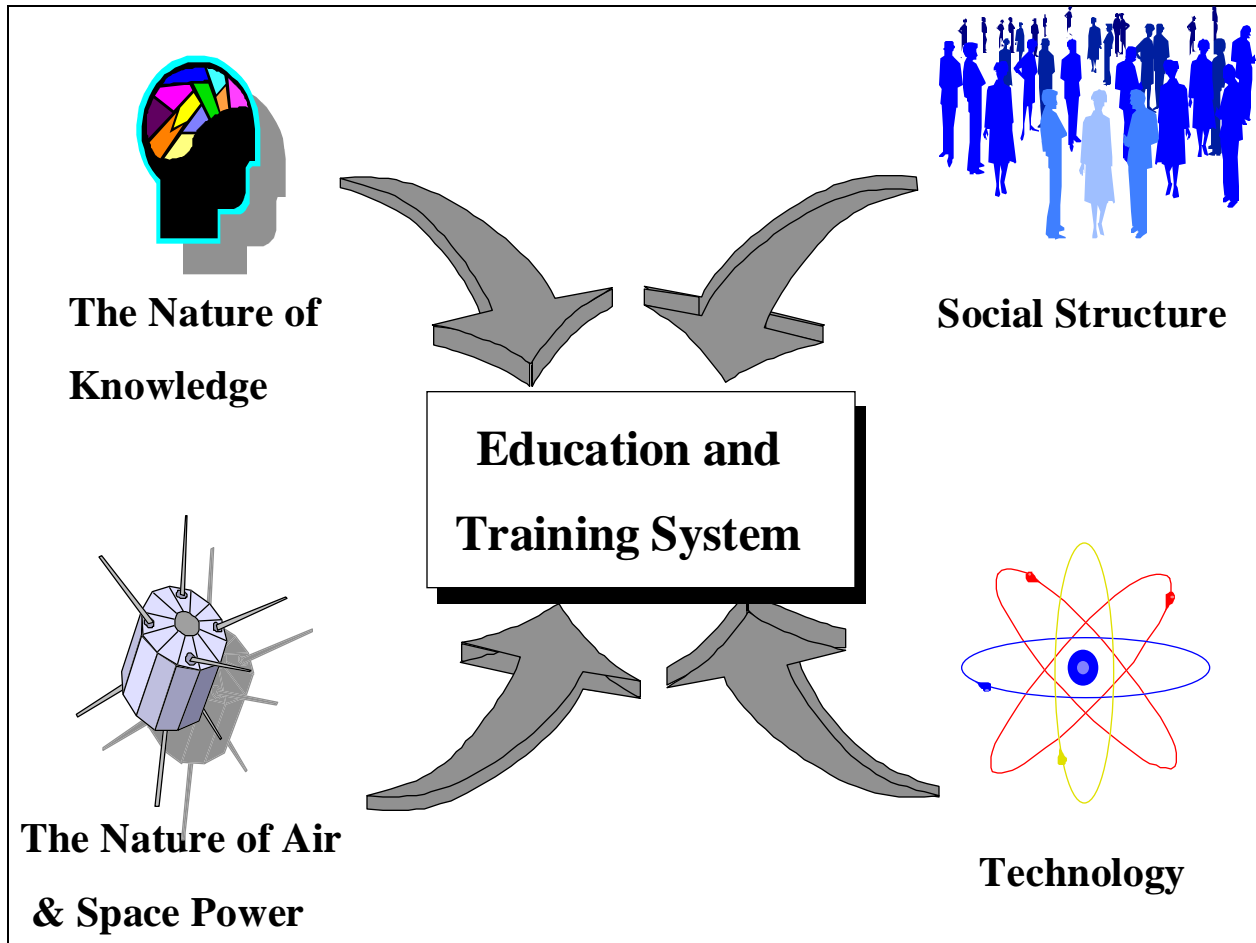
**Figure 2-2. Life-Cycle Model**

The life-cycle model illuminates those processes external to actual TRED programs that impact the brilliance of the force. They include accession programs and policies, advanced TRED selection mechanisms, post-TRED placement policies, and retention tools.



## **Drivers**

Developing a coherent vision for ET2025 requires at least a rudimentary understanding of the world in which it must operate. Christine A. Ralph MacNulty of Applied Futures offers insights into the process of mastering the future. She argues one key to future success is understanding what is happening in the external operating environment: to assess the spectrum of activity external to the organization, particularly with respect to developments in social, technological, and other driving forces.<sup>2</sup> A second essential to preserving the future is to look at an organization—or, for our purposes, a process—and understand its purposes and functions, how those functions could be performed better, and whether these will continue in the future. Having already addressed the former—purpose and function—we can answer the latter only with some understanding of the environment of 2025—and of the drivers that will create and enable it. We shall examine four such drivers that will be critical to the education and training process (fig. 2-3).



**Figure 2-3. Drivers**

### **Social Structure**

The warriors of 2025 will come from the “knowledge society,” a society enmeshed in the information revolution. This information society will demand more and more “knowledge workers”—workers having significant formal education and the ability to acquire/apply theoretical and analytical knowledge. However, this demand will occur in a society that may be unable to produce the required quantity of knowledge workers. In *The Road to 2015* John L. Peterson notes two trends heightening demand for knowledge workers in the future: an aging US population and an education system that graduates too many students ill-equipped for an information-based economy.<sup>3</sup>

Additionally, the warriors of 2025 will enter the service with different generational baggage from the warriors of 1995, or even 2005. Growing up in the technological age, they will be comfortable with computers, video games, and instant access to information. They also will be less patient, more accustomed to instant gratification, and demand stimulation, excitement, and speed in their lives. And they might seek out the military for challenges and responsibilities not found elsewhere.<sup>4</sup>

### **Technology**

Revolutionary and evolutionary technological development will challenge ET2025 in several ways. Technology will dramatically and rapidly change the tools of war and drive changes in the KSA required to wage war. The rapid pace of technological innovation also will require military professionals to anticipate the impact of emerging technologies on war-fighting capability and assess the implications of technological breakthroughs. ET2025 must be agile and flexible enough to satisfy these demands—and it must adapt to TRED challenges and opportunities more efficiently than our adversaries. Additionally, ET2025 must be flexible enough to incorporate emerging technologies as they apply to the learning process.

### **Nature of Knowledge/Learning**

The changing nature of knowledge will have a significant impact on ET2025—it will truly be not what you know that is important but what you know. The exponential increase in what we know and what we learn will continue to make “knowledge” and “understanding” increasingly fleeting states of mind. It is becoming increasingly difficult to “know” and “understand” at levels

of the past. In 2025 we will have to know how to know, how to decide what is important to know, to know what we don't know, and how to go about getting it.<sup>5</sup>

The nature of what we know will challenge ET2025, as the fundamentals that served us well in the past will fail us in the future. In *The Age of Social Transformation*, Peter F. Drucker provides insights as to how our definitions and concepts surrounding the TRED process must change with the changing nature of knowledge. First, he argues that the quest for and accumulation of advanced knowledge must continue well past the age of formal schooling. Next, he writes, our vision of an educated person must evolve. An educated person will be someone who has learned how to learn and who continues to learn throughout his or her lifetime. Further, a formal degree or testimonial will no longer validate someone's education, performance capacity will. Additionally, learning will become the tool of the individual, and knowledge will exist for the most part only in its application. Finally, Drucker believes the generalist will exist no longer.<sup>6</sup> This new methodology will dictate better use of "teams" to solve problems, since it will become increasingly difficult for one individual to grasp all necessary knowledge.

Closely related to the nature of knowledge is the nature of learning, which plays a complementary forcing role in envisioning ET2025. Leaps in our understanding of the cognitive process itself will offer insights into the nature of learning and provide opportunities to enhance the learning process. This growing sophistication about the nature of learning, for example, points towards individual learning and customized learning environments as critical concepts in an effective and efficient educational process.<sup>7</sup> Future discoveries in areas of nontraditional intelligences—spatial, musical, kinesthetic, interpersonal, and intrapersonal—also may offer opportunity to exploit new venues for educational purposes.<sup>8</sup>

## **Nature of Warfighting**

The nature of 2025's military forces will drive the TRED process that supports it. Two characteristics deserve our consideration. First, if current trends serve as a benchmark for the future, the military forces of the United States' must be prepared to participate in operations of varying complexity, from low-intensity conflict through full-scale war and across the ever-growing spectrum of "operations other than war." Concurrent with a commitment to a wide variety of missions, a United States that becomes more inextricably engaged around the world will commit its military forces to a high operations tempo. This tempo will distinctly impact the design of ET2025: forces generally will not be available to support long-duration TRED programs, and this ops tempo will limit the opportunities to train on operational systems.

### **ET2025 Imperatives**

The brilliant force that will dominate the 2025 battlespace will require a TRED environment—ET2025—to do so. ET2025 must incorporate the characteristics—and critical internal and external process illuminated earlier--and do so in the world of 2025 as suggested by the drivers. ET2025 must demonstrate certain operational characteristics and satisfy critical military needs. These, taken together, form the ET2025 imperatives:

- ET2025 must prepare brilliant warriors and leaders to act decisively in ambiguous and changing environments. It must prepare technologically aware and adept warriors. It must focus on developing wisdom instead of knowledge and on acquiring how to learn techniques as well as critical skills.

- ET2025 must provide the opportunity for continuous learning, on demand, any time, and anywhere. It must ensure minimal loss of productive job-related activity.
- ET2025 must recognize and adapt to individual differences. It must tailor TRED programs to each individual, his or her immediate TRED needs, and individual preparation and inherent cognitive and physical skills and aptitudes to achieve an optimum learning style.
- ET2025 must overcome barriers to effective learning within technological, physiological, and ethical constraints. It must incorporate technologies and learning environments that will increase human performance.
- ET2025 must be agile and flexible in responding to a rapidly changing external environment. It must quickly recognize emerging TRED needs. It must possess an agile and a responsive curricula development process. It must adapt and incorporate emerging TRED technologies.
- ET2025 must take advantage of improvements in simulation and modeling technology to provide realistic individual and team TRED alternatives. It must incorporate technologies to create virtual realism, to introduce human behavior into the simulation process, to network individual simulators for group and small-unit training, and to provide cost-effective training alternatives.
- ET2025 must enhance Brilliant Force by exploiting obvious synergism with service personnel management tools. It must exploit personnel classification technologies that enable matching personal KSA with required job skills. It

must match TRED programs with follow-on job requirements. It must enter into a partnership with accession, retention, selection (for TRED programs), and assignment policies to increase total-force capabilities.

- ET2025 must exploit education and training partnerships with sister services and national agencies, civilian universities, and commercial training programs.

It should focus on those KSA unique to Air Force and military operations and seek to consolidate education and training for more common TRED requirements.

### Notes

<sup>1</sup> Lt Gen Jay W. Kelley, “Brilliant Warrior,” (Unpublished article, Maxwell AFB, Ala.: Air University, 1996), 4-5.

<sup>2</sup> Christine A. Ralph MacNulty, “Social Change: The Often Ignored Driving Force” (Paper for the Industrial College of the Air Force, 20 January 1995), 2.

<sup>3</sup> John L. Peterson, *The Road to 2015: Profiles of the Future* (Corte Madera, Calif.: Waite Group Press, 1994), 15.

<sup>4</sup> Kelley, 7.

<sup>5</sup> Although deciding what is important to know (and, therefore, what is important to teach) is a critical element of any training or education program, we do not address it in this paper. Our emphasis is on building a system and a process which will enable the military of 2025 to teach anyone, anything, at any time. Thus, the *what* becomes less important to identify in advance as the *how* becomes more efficient and responsive.

<sup>6</sup> Peter F. Drucker, “The Age of Social Transformation,” *The Atlantic Monthly* 274, no. 5 (November 1994): 64–68.

<sup>7</sup> Individual learning is the focus of this paper. Team training, as in unit readiness training, will remain a necessity for the Brilliant Force of 2025; however, this paper does not discuss the processes or materials related to group training, except where they overlap with individual education and training.

<sup>8</sup> Jan Davidson, “White Paper: Multiple Dimensions to Learning,” 1–5. On-line, Internet, 15 March 1996, available from <http://vital.davd.com/vlpress/white.html>.

## **Chapter 3**

### **System Description**

The models, drivers, and assumptions above shape the TRED system to optimize learning in 2025. The ET2025 architecture is “agile education,” a combination of just-in-time training, training on demand, and tailored training made possible by expected advances in artificial intelligence (AI), virtual reality (VR), holography, and communications and computer technologies. Within the agile education system, the concepts of the national knowledge superhighway (NKS), academic centers of excellence, expert tutor (EXTOR), distance learning, and hyperlearning receive special attention. An additional section discusses the need for sophisticated screening processes to better match individual capabilities with military needs and some of the technologies under investigation.

### **Agile Education**

The military TRED community has investigated the concepts of just-in-time training, training on demand, and tailored training for a number of years, but no coherent plan for implementing these ideas has emerged. The value of such initiatives should be obvious: training tailored to the individual and the job to which he or she is assigned, provided when and where convenient to the trainee/trainer, would save the military time and money and make the force more flexible.



At the current time, service training and education caters to the average trainee and takes a predetermined length of time, regardless of the individual abilities of the students. For example, undergraduate flying training (UFT) students begin training on the same day, complete the same number of training sorties, and graduate a year later. The aforementioned system has been termed a pipeline: students crawl in the training pipeline together and pop out the other end in a clump, ready for assignments to the operational force. In times of dwindling budget and manpower, the pipeline is not (if it ever was) an efficient method for training.

Curiously enough, the world of manufacturing has a concept we can borrow and apply to TRED. It's called agile manufacturing. Agile manufacturing is the latest trend in industries where mass marketing has given way to "niche" marketing, where mass production of a standardized product has evolved into mass customization of personalized goods.<sup>1</sup> For example, the computer industry already has embraced agile manufacturing to a great extent. The customer can order a computer over the phone, specifying the precise processors, memory, monitor, and peripherals desired. One of the main purposes of agile manufacturing is "to get the product from concept to marketplace very quickly."<sup>2</sup>

Considering an appropriately trained and educated military member as the "product" and the gaining commands or agencies as the "marketplace," one begins to see the possibilities of agility when applied to TRED. Alphonso L. Hall, a plant manager for General Motors and a guru of agile manufacturing, talks of an agility analysis which is a "rigorous cost, responsiveness, quality, and performance test that can be applied to equipment, processes, and people. In addition, the test asks whether or not equipment and people are reconfigurable to make new products, and if the products themselves are reconfigurable."<sup>3</sup> The four standards Hall applies—cost, responsiveness, quality, performance—could equally well apply to TRED. Simple changes in

language show how easily we can transfer the concepts of agility to TRED. Military personnel are, of course, “reconfigurable” through TRED. The military should aim for truly agile education or agile TRED by 2025. Such a system would respond virtually instantaneously to the needs of the customer by identifying and teaching the right individuals to accomplish the mission—a combination of the tailored training and just-in-time concepts floating around now.

Consider the following scenario. It’s 2025. A cyberterrorist group has threatened to destroy France’s economy if their demands aren’t met. The US responds to France’s plea for assistance, and the secretary of defense asks the JPC (Joint Personnel Center) to assemble a team to stop the terrorists. Skimming through their databanks of information about individuals’ skills, knowledge, aptitude, and learning ability, JPC personnel identify 20 people for the task force. Agile TRED specialists immediately assess the TRED needs of each of the task force members and construct individualized programs (using virtual reality, simulation, and AI “agents”) which the members complete at their current locations. Some members receive only one or two blocks of instruction, some receive six, seven, eight . . . whatever they need, based on their current KSA levels and the task they must complete. Completely trained for the mission, the task force assembles (physically, if necessary) and neutralizes the cyberterrorists. They disband and return to their previous jobs or go on to new assignments, receiving necessary training en route.

To accomplish missions like these, the services need a new paradigm for training. The omnipresent image of a superhighway may be useful in reorienting our thinking away from the pipeline metaphor. The new TRED system should more nearly resemble an infinite highway with on-ramps and exits convenient to the trainee. The trainee will get on the highway at a point convenient to him or her and congruent with his or her current KSA and mission assignment. The trainee will exit the superhighway when he or she has learned the tasks or materials required or

desired. No longer will military personnel be trapped in a pipeline, waiting to complete unnecessary blocks of education or training and awaiting a preordained graduation day to move on to their gaining unit. The new system should allow students to enter training at whatever point their individual abilities dictate, give them precisely the training they need, and certify them when they've mastered the tasks/ideas, not on a predetermined date.

### **National Knowledge Superhighway**

Agile learning has one prerequisite which training and education have required: courseware designed in collaboration between subject matter experts and instructional program developers. However, the imperatives of ET2025 dictate that much of the curricula take a different form and function. The requirement for an agile curriculum development process, distance learning capabilities with learning on demand, and an active learning experience dictate the need for two critical system components: a central server hosting expert interactive courseware and specific training modules to serve the critical TRED needs of all DOD distant end users (the national knowledge superhighway) and a software-driven automated courseware development system incorporating expert systems technology to support it.

The automated courseware development system is a natural extension of the computer-aided design/engineering systems in use today. It incorporates emerging expert systems technology, the ability to automate production rules associated with instructional systems development, and the ability to model and replicate the human learning process to rapidly develop expert interactive courseware to support our national TRED needs. Likely to be available to courseware developers well before 2025, this capability will be essential to ensuring military forces can adapt quickly to the rapidly emerging TRED requirements of 2025.

While the technical capability to develop expert interactive courseware likely will exist before 2025, the ability to rapidly develop TRED tools in response to emerging requirements will face formidable challenges. In “Advanced Training Systems for the Next Decade and Beyond,” R. Bowen Loftin and Robert T. Savely, note that one of the greatest barriers to the development of expert systems has been, and likely will continue to be, the acquisition of the expert knowledge of a particular skill, task, or aptitude necessary to develop production rules.<sup>4</sup> Course content teachers and subject matter experts will remain critical nodes in ET2025. The expert courseware supporting 2025’s NKS will depend on the military’s ability to understand and to catalog/classify the specific KSA associated with each specialty and/or TRED objective. It will depend also on the capability to translate this expertise into a form exploitable by expert interactive teaching tools.

The NKS enables ET2025’s architecture to support the overarching notions of agile learning with tailored, on-demand, just-in-time learning capabilities available at a distance. It hosts the resident interactive courseware and training modules and links distant end users with the subject matter experts located in various DOD and accredited civilian centers of excellence. Similar in theory to the information superhighway, the NKS differs significantly in practice. It hosts not unfiltered information but accredited, interactive courseware designed to support initial skills training, follow-on refresher training, and the advanced education needs of military forces operating on land and sea and in the air and space. Further, it is secure. It will maintain strict access controls, allowing only specific courseware developers to place educational materials onto the server.

## **Academic Centers of Excellence**

Selected DOD and civilian institutions—the ET2025 Academic Centers of Excellence (ACE)—form the backbone of the agile learning capabilities of 2025. These centers of excellence, often the same sites responsible for developing the remaining resident TRED programs for the military and civil service forces (Maxwell Air Force Base (AFB), National Defense University, Fort Leavenworth, Harvard University, and other similar places), will be responsible for developing solutions and anticipating or reacting to existing and emerging TRED requirements. We anticipate each service will have one or more ACE to support service-specific TRED needs, and each service will provide the primary materials necessary to support the TRED requirements of joint and coalition forces.

ACE will be critical nodes in 2025. The best institutions will not merely add new technologies to their existing twentieth century structure. Rather, top-quality ACE will act as facilitators of learning; they will be repositories of the best in education and educational systems, ready to tailor the program to the needs of the students. Information technology will continue to reduce the need for students to travel to the information; educational centers will excel in moving the information to the student, reducing travel costs, and supercharging education and training agility.

The critical roles of an “electronic” educational institution built to meet the learning needs of the 21st Century will be as follows: to provide information on education and training needs and opportunities; to provide quality control; to provide accreditation, through independent assessment of learning; to develop coherent curricula, where appropriate; to broker and validate courses and materials from other education and training suppliers; to make it easy for teachers and learners to use communications technology to import and export multimedia learning materials; to network learners and instructors; to create high quality educational multimedia materials in an easily accessible form; to conduct research into education and training needs; to apply new technologies, as they develop, to education and training, and to evaluate their use.<sup>5</sup>

On the other hand, our DOD campuses will not become “ether” universities. Critical skills essential to effective military operations—leadership, discipline, motivation, teamwork, team building—will still require face-to-face interaction. But the electronic medium will reduce the amount of time spent in conventional classroom learning situations. Students will accomplish these lessons at home or at their assigned stations.

Clearly though, a center of excellence must evolve over the next 30 years to fulfill the need for high-quality educational multimedia curricula. This center of excellence, whether a pure DOD endeavor or a partnership with private industry, must be capable of producing large quantities of complex interactive training software for the highly capable educational systems of 2025. Air University at Maxwell AFB is the logical choice to lead in this role.

The academic centers of excellence will provide the courseware input to the education and training architecture of 2025. A new capability—the expert tutor—will help to manage the output.

### **Expert Tutor**

The expert tutor (EXTOR) will provide the interface between ACE and the end user—the student. An individualized, personal expert interactive training aid, EXTOR will satisfy many ET2025 imperatives. Focusing on knowledge application and learning, it will allow the user continuous learning opportunities. It will also tailor the learning process to the individual’s specific TRED needs and inherent cognitive skills and learning style, and it will incorporate state-of-the-art technologies for learning enhancement and virtual realism.

EXTOR is the generation after next of the computer aided instruction (CAI) capabilities currently in use in many training environments. Interactive Courseware documents many of the

systems' benefits in the TRED environment: increased training effectiveness, increased student participation and interest, increased knowledge retention, reduced time in training, reduced attrition levels, and reduced life-cycle training costs.<sup>6</sup> Clearly, CAI is congruent with ET2025's imperatives: it is reasonable and prudent to assume third- or fourth-generation CAI systems will be an integral part of and critical to the success of ET2025.<sup>7</sup>

NASA's intelligent computer-aided training (ICAT) capability has taken CAI to the next level, demonstrating impressive results in the application of expert systems to CAI. A modular system designed to emulate the behavior of an experienced instructor in the training process, ICAT has demonstrated the capability to provide trainees with much the same experiences as they could gain from the best on-the-job training programs.<sup>8</sup> EXTOR will take CAI at least one step beyond ICAT. Evolving from further research into expert systems, it will use expert systems and artificial intelligence to convert CAI into an instructional media to instruct, diagnose, and evaluate.<sup>9</sup>

Part of a modular, global learning environment, EXTOR enables and promotes active and individual distant learning. It is the expert computer interface to link the end user (student or trainee) with interactive courseware resident on the national knowledge superhighway (NKS). Serving as each individual's personal assistant, it will access information from available sources and present it in a format suited to the user's individual learning style. EXTOR consolidates many of the functions performed by NASA's ICAT system into a single, user friendly software interface performing the many functions. It allows the learner access to distant courseware and information via the NKS and NDB manages the training session carries out active and interactive tutoring based on its knowledge of the individual's optimum learning style watches for common student errors and provide corrective feedback maintains and updates a database containing

trainee's performance history and designs and executes increasingly complex training exercises based on its knowledge of the course objectives and individual's current KSA level and demonstrated weaknesses.<sup>10</sup>

EXTOR will be a lifelong learning companion for each service person. First used during accession testing, it will replace the current battery of skill and aptitude tests. It also will map each individual's KSA to determine suitability for Air Force operations and assist in initial placement. Mapping each individual's learning styles, it will determine the optimum learning approach to apply in subsequent training sessions. EXTOR also will serve several valuable institutional functions. It will perform personnel diagnostic, tracking, and assessment functions to assist in accession measurements and decisions, personnel classification systems, active skill-level certification, and selection processes for advanced training, follow-on education, and assignments.

EXTOR will require the integration of several critical technologies currently undergoing research on a limited basis and will require their availability on a wide scale. These requirements will include advancements in cognitive modeling and the ability to model the learning process; the development of expert systems, including the use of neural networks and fuzzy logic; the ability to acquire or develop knowledge to interface with EXTOR; and the development of virtual reality creation techniques to build and exploit each individual's optimum learning environment and learning style.

The combination of the first two technologies—cognitive modeling and the ability to model the learning process—will underpin the EXTOR of 2025. Current research into the study of the nature of knowledge and of human learning will result in the theoretical constructs necessary to build 2025's expert tutors. Fuzzy logic and neural networks, among other alternatives and



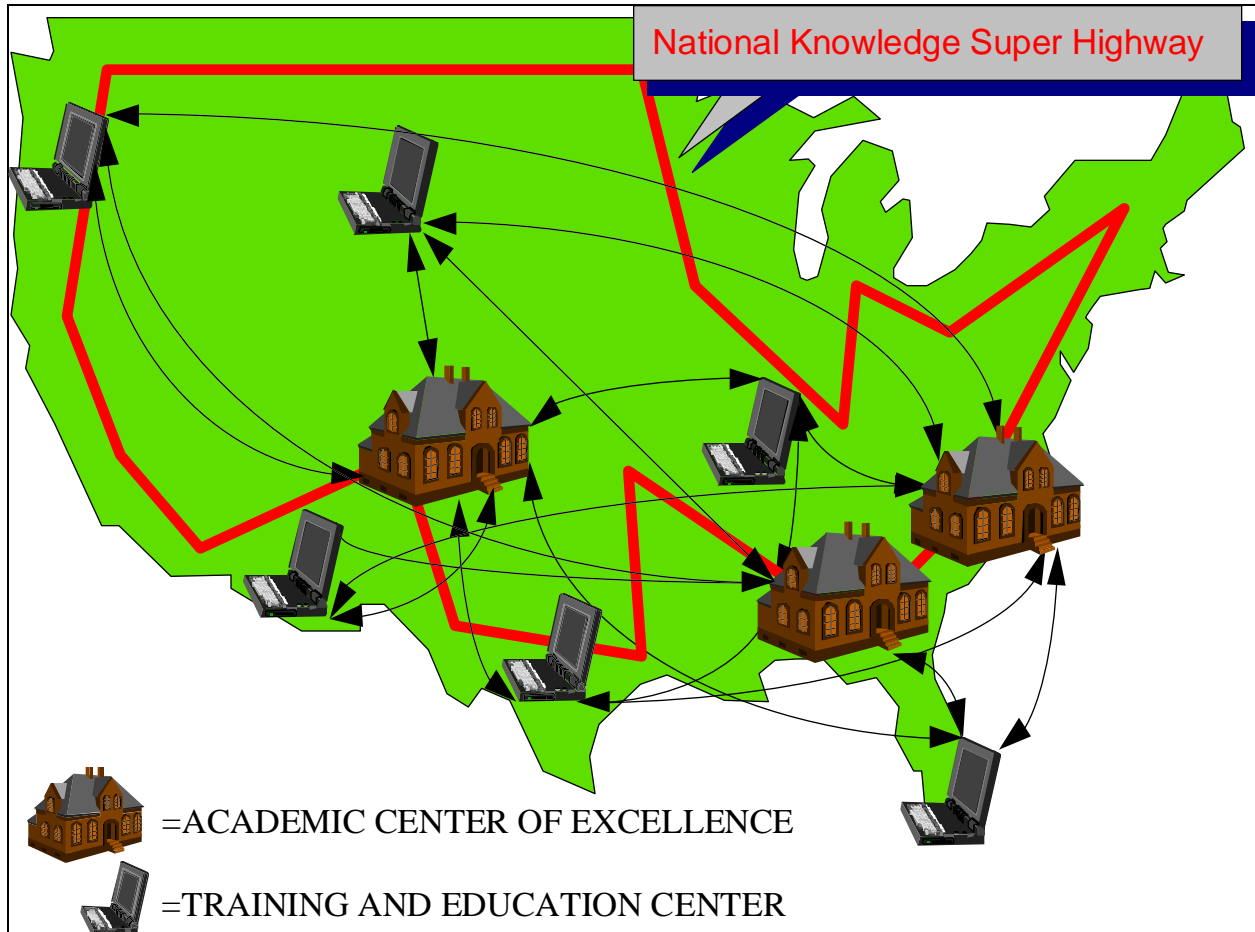
advancements in cognitive modeling techniques, may enable 2025's expert tutor to understand and to adapt to individual growth and learning processes. Loftin and Savely suggest fuzzy logic and neural network technologies will enable expert tutors to represent student mental states more accurately, assess individual KSA development and learning patterns, model individual trainees, adapt training to the individual's behavior to provide the optimum learning environment, and track and respond to complex lines of inquiry.<sup>11</sup>

EXTOR will also leverage state-of-the-art virtual environments to enable fully interactive distant learning. Cost has been one of the limiting factors in the application of virtual reality to the education and training environment. However, costs should decline in this area sufficiently by early in the twenty-first century to make this technology affordable for educational institutions.<sup>12</sup> By 2025, the technologies associated with virtual reality should enable this capability to be exploited for education and training purposes on a far-reaching scale.

Combining intelligent CAI with other emerging technologies and developments in advanced cognitive research offers great potential for further significant advances in autonomous, self-directed education and training tools, mainstays of agile TRED. According to the authors of "Plugging In: Choosing and Using Educational Technology," computer-based technologies derived "from artificial intelligence and research in cognitive science promote [active] learning. Such systems help learners think through complex, authentic problems; take charge of their own learning; and develop products for teaching or use in the real world."<sup>13</sup> The authors also state these systems, together with expert instructors, integrate media to provide sophisticated expert systems for learning complex concepts, help students develop advanced learning skills, diagnose student performance, adapt the level and sequence of problems based on student performance

and suggest directions for future learning, and simulate the use of emerging technologies and decision making to address complex real world problems.<sup>14</sup>

The EXTOR and its associated capabilities embody a key concept to lead the Air Force closer to agile TRED, with particular emphasis on tailored TRED available on demand. A notional system is depicted below in figure 3-1.



**Figure 3-1. Notional System Model**

### **Distance Learning**

The armed forces are no stranger to the distance learning concept, and considering the aforementioned drivers and required capabilities, the stewards of air and space power would do

well to position themselves to take further advantage of advances in this area. Distance learning may be the bridge to connect Air Force TRED in 1996 to the truly agile system postulated for 2025.

Both now and in the past, distance learning in the military has been a small, albeit significant slice of the education “pie.” Correspondence courses have filled selective niches, mostly to provide PME courses in lieu of in-residence attendance. However, the assumptions and drivers discussed earlier require a change to this limited approach to distance education. Obviously, the services must develop the capability to increase the availability, quality, and quantity of training and education to meet the demands of mission complexity; and we must be capable of doing it cheaply and efficiently. The distance learning concept of operation may hold the key to tackling the challenge.

The distance learning concept is gaining steam in the business world. AT&T’s Center for Excellence in Distance Learning is giving industry systems that provide interactive visual teaching or training where the instructor and students are geographically separated but connected by electronic media. AT&T reports several benefits from this learning concept, including reduced travel costs, the flexibility to add students as needed without incurring additional expense, real-time course material updates, access to remote experts, and the ability to train more people and to do so more often.<sup>15</sup>

Clearly, the distance learning concept addresses many of the required air and space TRED capabilities for ET2025. Additionally, much of the technology to make distance learning effective is already available and in use. Consequently, the question now becomes one of predicting the advances in distance learning concepts and technologies—in such areas as signal

processing and display technologies--over the next 30 years and the actions the services must take to leverage advantages in this concept.

For example, effective, compelling, and efficient distance learning will require an improvement in signal-processing technology. An all-optical network would expand capacity so that the exchange of video and large computer files would become routine.<sup>16</sup> Although all-optical networks are now in their infancy, we may assume that optical networks, or another as yet undiscovered signal-processing technology, will erase the current limitations in network communications by 2025.

Likewise, advances in display technology could well revolutionize the distance learning concept. Currently, most display technology is based on the ubiquitous cathode ray tube, a technology developed more than 50 years ago. New display technology, whether holography or another new technology, may truly change the way we interact with digital information. Peterson points out that “if holographic information can be digitized and therefore transmitted (assuming adequate bandwidth) to remote locations, a whole new era will open up. ‘Picturephones’ may project the person on the other end of the line into the middle of your room as a ‘light sculpture.’”<sup>17</sup>

It is one thing to read the script of the president’s speech on your computer screen; imagine if the president were able to present the speech live, in your own living room or study, through the medium of a 3-D holographic image. More significantly for TRED purposes, imagine the greatest professors and thinkers of the day in your own living room, teaching you. A concept from the 2025 study, “Holographic Meetings,” suggests using this same technology for meetings, rather than education. This dual-use technology could present benefits in several arenas.<sup>18</sup>

Thirty years from now, advances in virtual reality technology could make each air and space professional's home a virtual education "center of excellence." As software evolves and computing power increases, virtual reality will be used to present models of all kinds of complex dynamic systems. Soon it will be possible to engage multiple senses simultaneously, engendering a total response from the mind and the body that will be more than the sum of its parts.<sup>19</sup>

## **Hyperlearning**

The current teaching paradigm emphasizes, as described by Asghar Iran-Nejad and George E. Marsh II in *Discovering the Future of Education*, a focus on the memorization of various concepts and facts, thereby effectively fragmenting the learning process to such a degree that the results are inapplicable to the real world.<sup>20</sup> This cognitive learning paradigm holds that knowledge has a separate existence from the physical nervous system--it can exist outside the learner, waiting to be memorized and internalized. Current curricula generally mirror this cognitive structure; important knowledge is identified as a "sample of behavior" or some other sort of objective. By highlighting these critical knowledge "nuggets," we attempt to simplify the internalization of knowledge by breaking these mountains of data into manageable pieces. The information revolution has reinforced this concept: computers process and store information, then they readily reproduce it as required. As Iran-Nejad and Marsh explain:

Another implication is that there is no more to learning than storing information. Thus, even in modern cognitive neuroscience the brain plays an incidental role in memory and virtually no role in learning beyond memory, as many leading neuroscientists view brain components as being more like static storage disks than biological subsystems with critical roles to play. As a result, anyone familiar with how computers process and store information can play the role of an expert on learning.<sup>21</sup>

This paradigm cripples our ability to apply new knowledge to real life. Further, it may degrade our ability to learn information efficiently and effectively. Infants learn at an exponential rate without having the ability to cognitively memorize and internalize. Rather, infants learn by sensory stimulation, by actively solving real-life problems, and by experience. “Children are born with a remarkable capacity to learn and they do learn successfully from whole-brain experiences during the first few years of their lives until, that is, they enter school.”<sup>22</sup> This “whole-brain,” experience, or hyperlearning, is central to our concept for learning in 2025.

The hyperlearning concept acknowledges the unique capacity of the brain to learn when immersed in a total learning environment, and it rejects the old paradigm of the brain as computer. People learn most effectively through whole-brain experiences rather than rote memorization of facts and concepts. The human brain does not evolve as a solution to memory requirements; rather, its evolution is the result of intentional and sometimes spontaneous responses to problems in natural environments, where inputs and stimuli to multiple senses are available simultaneously to contribute to learning.<sup>23</sup> What form would this system take, and might it be available in 2025?

If education is to improve, and it must improve if our society is to continue to thrive in an increasingly complex and competitive world, teachers must be experts in human learning and development and not just subject-matter technicians. *At the base of this is the ability to devise a system that relates instruction to real-world applications.*<sup>24</sup>

The recent Star Trek movie, *Generations*, began with the characters conducting a promotion ceremony on the deck of a sailing ship. In the movie, the sailing ship, as well as the entire ocean environment, were depicted as a virtual reality simulation produced by a device called a “holodeck.” Advances in virtual reality by 2025 could make the holodeck concept a viable answer to several required capabilities. More importantly, such a system would actively support

the hyperlearning concept.<sup>25</sup> Current trends in simulation technologies demonstrate some movement towards this concept.

Air Force flying training, a major user of simulators and simulation technology, provides some insights into current simulation efforts. For starters, the current generation of simulators is hardware intensive. As an example, one of the most recently acquired and complex simulators, the B-1B Weapon System Trainer (WST), relies on several large mainframe computers for digital processing and two large cockpit sections (for both pilot and aft stations), each mounted on a complex three-axis-of-motion hydraulic system to simulate flight. Several large cathode-ray tubes make up the visual (outside the cockpit) system. Actual panels and displays, including disarmed ejection seats, make up the cockpit. Consequently, the entire system is large, expensive, and maintenance intensive.

Two Air Force Institute of Technology (AFIT) programs demonstrate the movement towards virtual simulators and away from system-specific physical simulators. The first program, the virtual cockpit, is a low-cost, manned flight simulator of an F-15E. The pilot flies the simulator using a hands-on throttle and stick (HOTAS) and has the capability to drop bombs, as well as fire rockets and guns. What makes this simulator different from everything used in the past is the revolutionary display system. The pilot observes the in-cockpit and out-of-cockpit imagery through a head-mounted display. The only physical instrumentality in the Virtual Cockpit is the HOTAS.<sup>26</sup>

The second AFIT program provides us with another example of the move towards virtual simulation and of its benefits. The virtual emergency room will be a “state-of-the-art virtual reality environment for use within emergency rooms.”<sup>27</sup> Doctors will be able to access virtual records, monitor a “patient’s” vital signs, and view radiological and other diagnostic data. Virtual

patients will test each doctor's ability to respond to trauma, aneurysms, poisonings, and other time-critical medical emergencies.

The move towards virtual simulation offers another advantage: the ability to be networked to expand training realism. The simulation lab at the Institute for Defense in Alexandria, Virginia, provided the central effort in the development of the SimNet system. Through SimNet, participants around the world are networked together and fight on a virtual battlefield. Peterson describes one such scenario.

Ships in the Pacific can have real-time radar displays that look like the "battlefield" located in North Carolina. Army tankers in trainers in Fort Knox, Kentucky, look out of their sights and see the same location-only from each of their individual perspectives. Air Force pilots in California can "fly" missions in support of other participants from their trainers at the same time.<sup>28</sup>

Clearly then, the next generation of simulation technology will have several ground-breaking characteristics. First, there will be intensive use of virtual reality display systems to improve simulation realism to "suspend disbelief." Also, the new generation of simulators will be software intensive rather than hardware intensive. Next, simulators will be increasingly networked to expand training opportunities. And, finally, the services will exploit simulators in areas of endeavor other than flying training, such as the medical simulation noted above.

The question now becomes, "What will simulation training look like in 2025, and how should the air and space forces leverage themselves to take advantage of developing concepts and technologies?" It is reasonable to assume advances in display technology, computer processing speed, and signal processing will make simulators even more realistic, software intensive, and network capable. It is also reasonable to assume more and more training and education--both flying and nonflying--will be done in simulators. These advances in technology, along with an increasing reliance and emphasis on simulator training, may lead to a merging of simulator



training into a single simulator platform, much like the holodeck previously described. Users would enter the holodeck and direct the computer to load whatever simulation program they needed, whether an emergency room simulation, a flying mission, or an airfield defense scenario. Enhanced realism and network capabilities would make possible highly realistic, inexpensive, and possibly more frequent joint training exercises. This software-intensive system would reduce the need for expensive, single purpose, maintenance intensive hardware-based simulators. We could afford more of them. The simulators could meet a wide variety of training needs, including flying training, surgical procedures, bomb disposal, base defense, and air traffic control--all in the same versatile simulator platform.

The realism inherent in this platform also could provide otherwise unavailable training. If current trends continue, increasing air traffic, along with increasing urbanization, may seriously impact the availability of actual flight training, especially in the low-level regime. Low-altitude simulator training, with realism sufficient to “suspend disbelief,” is just one example where the capability of “superrealistic” simulators could overcome environmental limitations.

The networking capabilities of a holodeck style simulator opens up a vast number of training and education possibilities. Complex joint exercises could be accomplished entirely in the ether. Students completing professional military education could network in a virtual classroom then work through a significant crisis like the planetary defense action of 2015. Leadership training scenarios, from the battlefield to the Air Operations Center, could be simulated with convincing realism. The possibilities are limited only by imagination.

Such a virtual system boasts many advantages that answer numerous required capabilities: being software intensive, it would be relatively inexpensive as well as easy to update; it would answer the problem of difficult environmental constraints to realistic training; and, it would

provide realistic training for complex real-world scenarios. Most importantly, the system would conform to and shape the new paradigm of hyperlearning. Participants would be immersed in a total learning environment, bathed in sound, light, and sensations of touch, smell, heat, cold, and pain. Through rich combinations of highly realistic sensory stimulation, realistic problem solving, and the total suspension of disbelief, we may be better able to exploit our exponential learning capabilities.

### **Enhanced Screening**

Enhanced screening capabilities are a necessary precursor for agile TRED, the overall concept that incorporates the ideals of just-in-time learning, learning on demand, and tailored learning.<sup>29</sup> To minimize the demands upon the education and training process and to enhance the overall quality of the Brilliant Force, the military must be able to identify and select the right person to receive the right training at the right time.

When we think of screening today, we think of testing: physical, emotional, and mental. We screen a person's health with X rays, family history questionnaires, blood tests, and eye tests. We screen physical ability with tests of strength, dexterity, speed, and flexibility. We screen mental ability with psychological and intelligence tests. People are asked to interpret inkblots, to indicate preferences, and to make word associations to understand their personality and behavior traits. Intelligence tests measure ability to reason, think, and recall information. These types of tests help employers to decide whom to hire and whether person A or person B is better suited for a particular task. Many corporations use the tests, and the results from these tests indicate they work. More and more, the corporate world is using screening techniques to make decisions about people and their training and education. Why? Because this method is a cost-effective

way to ensure time and money are not being wasted on the wrong training for the wrong employee.

Joseph Matarazzo, winner of the 1991 APA Distinguished Professional Contributions to Knowledge Award, indicates emerging tests and their offshoots may offer some “different approaches” to the screening.<sup>30</sup> For example, biological tests (such as electrocardiogram readings), nerve response reaction time measurements and brain-imaging techniques may prove useful in predicting human performance in certain areas. Matarazzo predicts advances in these biological-physiological-behavioral processes will help us to measure intelligence and cognitive capacities.<sup>31</sup> The emotional quotient concept submitted to the 2025 study suggests we measure and screen for “qualities of the mind like empathy, discipline, fairness, tenacity.”<sup>32</sup> The author suggests such testing will allow the military to assess how an individual will react in a crisis situation more accurately. Using a variety of these screening techniques and then loading them into data systems will provide a multitude of opportunities for enhancing Air Force TRED in 2025. Indeed, accurate and updated screening is a prerequisite for the agile TRED system discussed earlier.

A variant of Armstrong Laboratory’s Intelligence Tutoring System (ITS) could be used to predict someone’s capabilities.<sup>33</sup> The futuristic versions of the ITS involve a VR tutor “with facial expressions and voice.” The student learns in an immersive learning environment wherein the “learners can move their own hands to pick something up.”<sup>34</sup> Not only will students learn tasks through kinesthetic feedback, they will have one-on-one lectures from VR tutors like Sun Tzu or Aristotle.

By immersing an individual into a VR situation, the ITS also can be adapted for screening. This variant—an intelligent screening system (ISS)—will provide individuals with a totally new

and unknown problem, evaluate the results of the individual's attempt to react and perform the desired tasks, and explore the individual's abilities to adapt and to learn. The ISS combines Matarazzo's measurement tools, data on the human brain, and advances in predictive neural-network technologies, which together might lead to identifying supercritical task ability. Imagine being able to identify and predict which individuals have the capacity for some presently unknown supercritical task. Or, not finding the perfect individual to accomplish a particular military task, imagine having the capability to identify the best qualified of those available for consideration. The military could not only identify the best qualified candidates, it could identify and tailor the specific type and quantity of training required to fully develop their skills—regardless of their initial knowledge or skill level. Advances in screening technologies need to be an integral part of the military's Brilliant Force architecture.

### Notes

<sup>1</sup> Editors, "Custom Manufacturing," *Scientific American*, September 1995, 160.

<sup>2</sup> Brian Moskal, "Son of Agility," *Industry Week*, 15 May 1995, 14.

<sup>3</sup> *Ibid.*, 12–14.

<sup>4</sup> R. Bowen Loftin and Robert T. Savely, "Advanced Training Systems for the Next Decade and Beyond," 1991, 10. On-line, Internet, 22 February 1996, available from <http://www.jjsc.nasa.gov/ccsb/ica/docs/NextDecade.html>.

<sup>5</sup> A. W. Bates, "Strategies for the Future," keynote address, n.p. On-line, Internet, 13 March 1996, available from <http://oilpatch.scheist60.bc.ca/papers/dusseldorf.html>.

<sup>6</sup> "Interactive Courseware." On-line, Internet, 18 April 1996, available from [http://www.sc.ist.ucf.edu/~OTT/1\\_2/index.htm](http://www.sc.ist.ucf.edu/~OTT/1_2/index.htm).

<sup>7</sup> 2025 concepts, no. 900088, "Interactive Books" and no. 900099, "Instructional Technologies to Enhance Leaders," 2025 concepts database (Maxwell AFB, Ala.: Air War College/2025, 1996). These concepts are essentially talking about EXTOR and its associated capabilities.

<sup>8</sup> Loftin and Savely, 2.

<sup>9</sup> "Interactive Courseware."

<sup>10</sup> Loftin and Savely, 6.

<sup>11</sup> *Ibid.*, 10.

<sup>12</sup> *Ibid.*

<sup>13</sup> Beau Fly Jones et al, "Plugging In: Choosing and Using Educational Technology," 4. On-line, Internet, 26 March 1996, available from <http://www.cic.net/ncrel/sdrs/edtalk/toc.html>.

<sup>14</sup> Ibid.

<sup>15</sup> AT&T Center for Excellence in Distance Learning. On-line, Internet, 13 March 1996, available from <http://www.att.com/cedl>.

<sup>16</sup> Vincent W. S. Chan, "All Optical Networks," *Scientific American*, September 1995, 57.

<sup>17</sup> Peterson, 62.

<sup>18</sup> 2025 concept, no. 900680, "Holographic Meetings," 2025 concepts database (Maxwell AFB, Ala.: Air War College/2025, 1996).

<sup>19</sup> Brenda Laurel, "Virtual Reality," *Scientific American*, September 1995, 70.

<sup>20</sup> Asghar Iran-Nejad and George E. Marsh II, "Discovering the Future of Education," *Education* 114, no. 2 ( ): 250.

<sup>21</sup> Ibid., 253.

<sup>22</sup> Ibid., 256.

<sup>23</sup> Ibid.

<sup>24</sup> Ibid.

<sup>25</sup> 2025 concepts, no. 200007, "Rehearsal for all Missions, in all Mission Media, Without Vehicle Movement" (PROPRIETARY), no. 900643, "On-Platform Initial Flying Training," no. 900175, "Virtual Reality Trainers," no. 900516, "Generation X Theater Level Combat Simulation," no. 900534, "Virtual Force 2025," no. 900629, "VR for Cultural Competence," and no. 900680, "Holographic Meetings," 2025 concepts database (Maxwell AFB, Ala.: Air War College/2025, 1996). These concepts outline various virtual reality/simulation ideas pertinent to 2025.

<sup>26</sup> Air Force Institute of Technology home page. On-line, Internet, 18 March 1996, available from <http://www.afit.af.mil>.

<sup>27</sup> Ibid.

<sup>28</sup> Peterson, 46.

<sup>29</sup> 2025 concepts, no. 900645, "Right Pilot," no. 900431, "Prescreening of Pilots," no. 900377, "Emotional Quotient," and no. 900569 900680, "PRE-TRAINED` SERVICE PERSONNEL," 2025 concepts database (Maxwell AFB, Ala.: Air War College/2025, 1996). Concepts, , , and refer to the need for enhanced screening mechanisms and are incorporated in whole or part in this section.

<sup>30</sup> Joseph P. Matarazzo, "Psychological Testing and Assessment in the 21st Century," *American Psychologist* 47, no. 8 (August 1992): 1009.

<sup>31</sup> Ibid., 1013.

<sup>32</sup> 2025 concept, no. 900377, "Emotional Quotient," 2025 concepts database (Maxwell AFB, Ala.: Air War College/2025, 1996).

<sup>33</sup> Valerie Shute and Joseph Psotka, "Intelligent Tutoring Systems: Past, Present and Future," (Air Force Material Command: Brooks AFB, Tex., May 1994).

<sup>34</sup> Ibid., 41.

## **Chapter 4**

### **Concept of Operations**

Kelly was born in the year 2005. Kelly's childhood years were spent playing video and virtual reality (VR) games, with some physical playground activity with other children. In 2010 Kelly began school and spent hours in front of a computer terminal at the interactive school desk. Few books were issued as the information was either read, heard, or seen by way of the computer. Students took almost all tests on the computer. Typing skills were honed, and writing skills were marginal. By 2020 Kelly was talking to an interactive system rather than typing. Keyboards were backups.

In 2025 Kelly joined the United States military forces and underwent a series of psychological, emotional, and physical tests to evaluate cognitive and physical skills and aptitudes. In addition, Kelly's last five years of school work was added to the Joint Personnel Center's KSA database. The tests showed Kelly was best suited for service as an Interplanetary Defense System technician.

Initially, Kelly entered basic military indoctrination and training. Kelly joined a class of 70 other new recruits for a three-to-six week indoctrination program. During the first two weeks, trainees were subjected to "historical training methods" where they experienced 1996 methods of military training. They increased their fitness level through cardiovascular and strength training

exercises, shot nonenergy type weapons, were restricted to certain activities, and learned to work together as a group. The DOD retained this training because it provided a foundation for later operations and instilled backup military fundamentals should modern techniques be rendered unusable.

Following the two-week group interaction, the trainees began their tailored training programs. This phase lasted one to three weeks, depending on the individual. Each trainee spent several periods per day in the TRED center where an individually tailored EXTOR helped the trainee to develop the balance of knowledge needed for induction in the military. This knowledge included leadership and followership techniques, values and ethics training, critical thinking skills, and military history, among other topics.

Upon induction as a T-0 (technician apprentice), Kelly moved on to the first duty station. Once there, Kelly checked into the TRED center for skill training. (Rather than traveling to a dedicated training base, Kelly could receive all skills training locally.) Kelly was introduced to the computer at the TRED center. The computer accessed all databases concerning Kelly's previous training and networked with the database for Interplanetary Defense Systems. The EXTOR synthesized all module training curricula with what it has already learned about Kelly's KSA and then tailored a training program. Kelly then became immersed in a VR holodeck to rapidly learn everything necessary to keep the Interplanetary Defense Systems operable. Kelly was then an initially qualified IDS technician and received the requisite pay raise and promotion to T-1.

One day Kelly was directed to participate in a combined exercise. Environmental limitations had for years prevented physically large military forces from actually exercising together. Since 2011, all major exercise had been conducted "virtually" with tremendous cost savings and

minimal environmental impact. Organized, planned, and executed by SimNet at Norfolk, the exercise involved several nations' military forces, as well as other organizations (United Nations, Centers for Disease Control, and Greenpeace). Prior to exercise kick off, Kelly visited the TRED center to update skills via EXTOR, which had identified new techniques since Kelly's last visit to the TRED center. Kelly's highly successful performance in the giant exercise earned Kelly a promotion to journeyman IDS technician (T-4). In addition, Kelly received a performance-based raise. Now Kelly was eligible for his next phase of military education.

On off-duty time, Kelly visited the TRED center to continue leadership and judgment education. The EXTOR provided Kelly the curricula online from the Maxwell Leadership Center of Excellence, and Kelly learned more about leadership, judgment, integrity, and military values. After completing these modules, Kelly reported to the Collaborative Leadership Laboratory (CLL) at Maxwell (7-10 days) for interpersonal bonding with peers and face-to-face leadership experiences and exercises. The Microbrewery in downtown Montgomery remains a premier site for after-hours bonding. Having completed CLL, Kelly returned to the original duty station.

A contingency arose and the folks at JPC identified Kelly from their database as possessing the appropriate KSA to participate in the operation. Notified of this assignment, Kelly reported to the TRED center, and the EXTOR shuttled off to the curriculum banks to retrieve courses on asteroid composition, trajectory physics, and language training—courses which Kelly completed before connecting with the rest of the ad hoc team through the holodeck to rehearse the entire scenario. If necessary, Kelly could have deployed with the rest of the specially selected team to fulfill specific military objectives.



Throughout a 20-year career, Kelly continued to learn and advance. Learning opportunities were always available and most military members took advantage of them to increase their rank, pay, and responsibilities.

## **Chapter 5**

### **Recommendations**

Technologies coming of age in the first quarter of the twenty-first century should make agile TRED possible. Several of the technologies inherent in the ET2025 architecture likely will be available well before 2025.<sup>1</sup> Nonetheless, it may be 2025 before these ideas and capabilities warrant the confidence necessary to allow their implementation on a global scale. For example, there will be great reluctance to allow automated, interactive courseware and expert training aids to replace the direct personal interactions upon which we traditionally rely for instruction, evaluation, and validation. Therefore, these concepts must undergo a significant validation process (10 years?) to prove their efficacy.

The armed forces must conduct validation testing of several major areas prior to embracing these capabilities to build the brilliant force. The services are currently developing learning ability measurement programs, advanced selection tools, and other personnel testing programs that will be available prior to 2025. However, prior to employing these technologies in Brilliant Force applications, the military must conduct significant validation testing in parallel with more traditional force maintenance tools to verify, validate, and build high levels of confidence in their performance predictive abilities. On a parallel note, the military must validate the performance of automated, interactive, and distance learning technologies by conducting a scientific analysis

comparing their performance with more traditional teaching methods. It is entirely possible the technology advocated to build the Brilliant Force architecture will not prove feasible for all types of TRED requirements. This analysis and testing period must illuminate which TRED opportunities demonstrate the greatest payback for applying future learning technologies to particular situations.

Agile TRED can become a reality for the air and space services of the future if we invest in the right technologies and discard the pipeline paradigm for TRED. Concurrent with revamping our TRED structures, we may also need to change our compensation (rank/pay) structures. Tom Broersma, a consultant specializing in developing high-performance learning organizations, suggests twenty-first century organizations, including government agencies, will operate more effectively if people are paid based on their knowledge and skills, rather than longevity. He further suggests that teams should evaluate their members based on performance, and then use performance to determine promotion and salary.<sup>2</sup> Among other things, this scheme would establish motivation for members to acquire TRED on their own, decreasing the on-duty time required to train personnel. To Broersma, effective organizations will view the capacity to learn—both individually and as an organization—as a competitive advantage and will view training as an investment strategy.<sup>3</sup>

As the services consider adopting new training paradigms, they also should consider adopting new training partners. To paraphrase Alphonso Hall, agile education requires an enterprise-wide view that takes advantage of forming alliances with other organizations to fulfill mutual goals.<sup>4</sup> The military should consider cooperation with academia and corporate America to meet TRED requirements in 2025. Many military specialties, particularly in medicine, engineering, and the sciences, have requirements that mirror the training requirements of their counterparts in the

civilian world. Would it not make sense in a future where educated, intelligent people will be at a premium, to encourage cooperation, rather than competition, with the corporate world?

Using the current reserve system as a point of departure, the military and the corporate world could arrive at some workable solution which would cut initial and continuing training costs for each and provide increased communication and understanding of each other's needs and goals.<sup>5</sup> Mutual investment in and development of agile training technologies—VR and AI--and sharing of those technologies, rather than of the human resources, might provide an alternate means of establishing cooperation with industry.<sup>6</sup>

Finally, it is likely that sophisticated education and training technologies and sophisticated screening tools may not prove to be cost-effective for all career fields or skills. To make the best use of these emerging technologies, the services should review their specific needs to identify mission-critical, service-unique skills and capabilities that could be well served by advancements in selection and TRED technologies. Further, the services also should work to identify those skills that could be provided through nonmilitary training, either before accession or through cooperation with industry. The concept paper, "Pre-Trained Service Personnel," also suggests this, noting the services could recruit personnel based on their educational and technical qualifications.<sup>7</sup>

Emerging technologies in education and training, suitably cultivated and appropriately validated, have tremendous potential to revolutionize military education and training. Advanced screening techniques, advances in artificial intelligence and artificial reality, and continuous improvements in computing and communications technology will enable a truly "agile" education and training architecture by 2025. This architecture, consisting of such elements as the national knowledge superhighway, academic centers of excellence, and expert tutors, will bring the

concepts of just-in-time learning, learning-on-demand, and tailored learning to fruition and will underpin the success of the Brilliant Force across the full spectrum of military operations.

### Notes

<sup>1</sup> Several other concepts submitted to the 2025 study detail technologies or ideas already accessible; they could be implemented in 1996 if anyone chose to do so. Thus, the following concepts are not included in this 2025 white paper: 900174, 900327, 900644, 900247, 900171, 900349, 900119, 900226, 900631.

<sup>2</sup> Tom Broersma, "In Search of the Future," *Training and Development*, January 1995, 39.

<sup>3</sup> Ibid.

<sup>4</sup> Moskal, 14.

<sup>5</sup> Kimball and Young, "Educational Resource Sharing and Collaborative Training in Family Practice and Internal Medicine," *Journal of the American Medical Association*, 25 January 1995, 320.

<sup>6</sup> 2025 concepts, no. 900174, "Contracted Support Infrastructure" and no. 900247, "Enhanced Total Force," 2025 concepts database (Maxwell AFB, Ala.: Air War College/2025, 1996). These concepts tie in with this. The first one advocates contracting out most support functions and becoming a single service. The most significant drawback to this would be the nondeployability of contracted personnel during hostilities. The second concept suggests a greater use of the guard and reserve forces which might be more feasible if a comprehensive program of cooperation with industry were initiated.

<sup>7</sup> 2025 concept, no. 900569, "'Pre-Trained' Service Personnel," 2025 concepts database (Maxwell AFB, Ala.: Air War College/2025, 1996).

## **Appendix A**

### **Technologies and Capabilities Summary**

Table 1 lists the key Brilliant Force concepts and subsystems, and isolates each with respect to the technologies and capabilities upon which it builds. The resulting matrix visually depicts two key notions: the technologies and capabilities most critical to the development of advanced learning and TRED architectures for 2025. It also depicts those concepts and subsystems relying on the broadest spectrum of technological advancements to achieve full utility.

From this chart, we can discern that the education and training architecture envisioned for 2025 relies heavily on continuing technological advancements in three primary areas: artificial intelligence, expert/adaptive systems, and computing power. Further, it appears that the concepts requiring advancements across the broadest spectrum of technologies include the full use of enhanced screening capabilities and the development of a hyperlearning capability.

**Table 1**  
**Technologies and Capabilities**

<div style="border: 1px solid black; padding: 5px; width: fit-content; margin: 10px auto;">CONCEPTS &amp; SUBSYSTEMS</div> <div style="border: 1px solid black; padding: 5px; width: fit-content; margin: 10px auto;">TECHNOLOGIES &amp; CAPABILITIES</div>	PHYSICAL/COGNITIVE TESTING	COGNITIVE MODELING	JOBS SKILLS CLASSIFICATION	PERFORMANCE PREDICTION	LONG-HAUL HIGH-BANDWIDTH COMM	ARTIFICIAL INTELLIGENCE	EXPERT/ADAPTIVE SYSTEMS	VIRTUAL REALITY/HOLOGRAPHY	ENHANCED COMPUTER PERFORMANCE
ENHANCED SCREENING	X	X	X	X		X	X	X	X
LEARNING ON DEMAND					X				X
TAILORED LEARNING		X				X	X		X
EXPERT TUTOR		X				X	X		X
NATIONAL KNOWLEDGE SUPERHIGHWAY					X				X
ACADEMIC CENTERS OF EXCELLENCE					X		X		X
HYPERLEARNING	X	X	X		X	X	X	X	X
AUTOMATED COURSEWARE DEVELOPMENT			X			X	X		X
INTERACTIVE ADAPTIVE COURSEWARE			X				X		X

## *Bibliography*

- Air Force Institute of Technology home page. On-line, Internet, 12 March 1996, available from <http://www.afit.af.mil>.
- AT&T Center for Excellence in Distance Learning. On-line, Internet, 13 March 1996, available from <http://www.att.com/cedl>.
- Bates, A.W. "Strategies for the Future." Unpublished keynote address for European Commission Telematics Applications Programme, 24–26 November 1994. On-line, Internet, 13 March 1996, available from <http://oilpatch.schdist60.bc.ca/papers/dusseldorf.html>.
- Broersma, Tom. "In Search of the Future." *Training and Development*. January 1995, 38–43.
- Chan, Vincent W. S. "All Optical Networks." *Scientific American*. September 1995, 56–59.
- Clark, Donald. "A System Approach to Training." On-line, Internet, 1995, available from <http://www.nwlink.com/~donclark/sat1.html>.
- 2025 concept, no. 900174, "Contracted Support Infrastructure," 2025 concepts database (Maxwell AFB, Ala.: Air War College/2025, 1996).
- 2025 concept, no. 900247, "Enhanced Total Force," 2025 concepts database (Maxwell AFB, Ala.: Air War College/2025, 1996).
- 2025 concept, no. 900377, "Emotional Quotient," 2025 concepts database (Maxwell AFB, Ala.: Air War College/2025, 1996).
- 2025 concept, no. 900569, "Pre-Trained Service Personnel," 2025 concepts database (Maxwell AFB, Ala.: Air War College/2025, 1996).
- 2025 concept, no. 900680, "Holographic Meetings," 2025 concepts database (Maxwell AFB, Ala.: Air War College/2025, 1996).
- "Custom Manufacturing." *Scientific American*. September 1995, 126–27.
- Davidson, Jan. "White Paper: Multiple Dimensions to Learning" 1–5. On-line, Internet, 15 March 1996, available from <http://vital.davd.com/vlpress/white.html>.
- Drucker, Peter F. "The Age of Social Transformation." *The Atlantic Monthly* 274, November 1994: 64–68.
- Gardner, Howard. *Multiple Intelligences*. New York: Basic Books, 1993.
- "The Human Genome Project." On-line, Internet, 18 August 1995, available from [http://www.ornl.gov/TechResources/Human\\_Genome/project/project.html](http://www.ornl.gov/TechResources/Human_Genome/project/project.html).
- "Human System and Biotechnology Volume (draft)." *New World Vistas Air and Space Power for the 21st Century* (1996).



- “Interactive Courseware.” On-line, Internet, 20 March 1996, available from [http://www.sc.ist.ucf.edu/~OTT/1\\_2/index.htm](http://www.sc.ist.ucf.edu/~OTT/1_2/index.htm).
- “Interview with Lewis J. Perelman.” *Seattle Times* (2020 world@seattimes.com), 28 November 1994.
- Iran-Nejad, Asghar and George E. Marsh II. “Discovering the Future of Education.” *Education* 114: 250.
- Jones, Beau Fly, et al. “Plugging In: Choosing and Using Educational Technology,” 4. On-line, Internet, 25 April 1996, available from <http://www.cic.net/ncrel/sdrs/edtalk/toc.html>.
- Kelley, Jay W. “Brilliant Warrior.” Unpublished article, Maxwell AFB, Ala.: Air University, 1996.
- Kimball, Harry R., and Paul R. Young. “Educational Resource Sharing and Collaborative Training in Family Practice and Internal Medicine.” *Journal of the American Medical Association* 273. 25 January 1995, 320–22.
- Kotter, John P. “Lifetime Learning: The New Educational Imperative.” *The Futurist*. November-December 1995, 27–29.
- Kulieke, M., et al. “Why Should Assessment be based on a Vision of Learning.” On-line, Internet, 9 February 1996, available from [http://cedar.cic.net/ncrel/sdrs/areas/rpl\\_esys/assess.htm](http://cedar.cic.net/ncrel/sdrs/areas/rpl_esys/assess.htm).
- Kyllonen, Patrick C., and Valerie J. Shute. *Taxonomy of Learning Skills*. Brooks AFB, Tex.: Armstrong Laboratory.
- Lateiner, Joseph S. “Of Man, Mind and Machine: Meme-Based Models of Mind and the Possibility for Consciousness in Alternate Media.” On-line, Internet, 10 December 1992, available from <http://www.dataspace.com/WWW/documents/consciousness.html>.
- Laurel, Brenda. “Virtual Reality.” *Scientific American*. September 1995, 70.
- Loftin, R. Bowen, and Robert T. Savely. “Advanced Training Systems for the Next Decade and Beyond,” 1991, 10. On-line, Internet, 13 February, available from <http://www.jjsc.nasa.gov/ccsb/ica/docs/NextDecade.html>.
- Lunken, Jonah. “Cognitive Modeling and Intelligent Tutoring.” On-line, Internet, 17 January 1994, available from <http://www.cc.gatech.edu/cogsci/educaton/courses/cs811/presentations/anderson.html>.
- MacNulty, Christine A. Ralph. “Social Change: The Often Ignored Driving Force.” Paper for the Industrial College of the Air Force, 20 January 1995.
- “A Manager’s Guide to Neural Networks.” On-line, Internet, 1995, available from <http://www.mindspring.com/~zsol/mgrguid.html>.
- Matarazzo, Joseph P. “Psychological Testing and Assessment in the 21st Century.” *American Psychologist* 47. August 1992, 1007–18.
- Melevede, Patrick E. “Neuro-Linguistic Programming, Frequently Asked Questions.” On-line, Internet, 17 December 1995, available from <http://ourworld.compuserve.com/homepages/patrickM/NLPFAQCS.htm>.

- Moskal, Brian. "Son of Agility." *Industry Week*. 15 May 1995, 12–17.
- Noam, Eli M. "Electronics and the Dim Future of the University." *Science* 270. 13 October 1995, 247–49.
- Peterson, John L. *The Road to 2015: Profiles of the Future*. Corte Madera, Calif: Waite Group Press, 1994.
- Ravitch, Diane. "When School Comes To You." *The Economist*. September 1994, 43–49.
- Robbins, Steve. "Neuro-Linguistic Programming: A Definition." On-line, Internet, 27 February 1996, available from <http://www.nlp.com/NLP/whats-nlp.html#name>
- Salvador, Roberta. "What's New in Artificial Intelligence?" *Electronic Learning*. January 1995, 14.
- Scott, William B. "Neurotechnologies Linked to Performance Gains." *Aviation Week and Space Technology*. 15 August 1994, 55–56.
- Shute, Valerie J. *Individual Differences In Learning From An Intelligent Discovery World: Smithtown*. Brooks AFB, Tex.: Armstrong Laboratory, June 1990.
- . *Learning Processes and Learning Outcomes*. Brooks AFB, Tex.: Armstrong Laboratory, June 1992.
- Shute, Valerie J. and Joseph Psotka. *Intelligent Tutoring Systems: Past, Present and Future*. AFMC: Brooks AFB, Tex., 1994.
- Shute, Valerie J. and Lisa A. Gawlick-Grendell. *If Practice Makes Perfect, What Does Less Practice Make?* Brooks AFB, Tex.: Armstrong Laboratory, 1992.
- Shute, Valerie J. and Carmen M. Pena. *Acquisition of Programming Skills*. Brooks AFB, Tex.: Armstrong Laboratory, 1989.
- Shute, Valerie J. and Patrick C. Kyllonen. *Modeling Individual Differences in Programming Skill Acquisition*. Brooks AFB, Tex.: Armstrong Laboratory, 1990.
- "TMI: Hemi-Sync(R) Learning Systems." On-line, Internet, 1994, available from <http://www.monroe-inst.com/programs/hemi-sync.html>. The Monroe Institute.
- "Training Partners . . . Computer Based Training at Your Desktop." On-line, Internet, 20 March 1996, available from <http://www.jmmahon.com/tpartner/index.htm>.
- Twiggs, Carol. "National Learning Infrastructure, Part 1." On-line, Internet, 14 March 1996, available from <http://sunsite.unc.edu/horizon/gem/gemtwigl.html>.
- USAF Scientific Advisory Board. *New World Vistas: Air and Space Power for the 21<sup>st</sup> Century*, Summary Volume. Washington, D.C.: USAF Scientific Advisory Board, 15 December 1995.

**Brilliant Warrior:  
Information Technology Integration  
in Education and Training**



A Research Paper  
Presented To

Air Force *2025*

by

Lt Col Carol S. Sikes  
Dr. Adelaide K. Cherry  
Maj William E. Durall  
Maj Michael R. Hargrove  
Maj Kenneth R. Tingman

August 1996

## **Disclaimer**

**2025** is a study designed to comply with a directive from the chief of staff of the Air Force to examine the concepts, capabilities, and technologies the United States will require to remain the dominant air and space force in the future. Presented on 17 June 1996, this report was produced in the Department of Defense school environment of academic freedom and in the interest of advancing concepts related to national defense. The views expressed in this report are those of the authors and do not reflect the official policy or position of the United States Air Force, Department of Defense, or the United States government.

This report contains fictional representations of future situations/scenarios. Any similarities to real people or events, other than those specifically cited, are unintentional and are for purposes of illustration only.

This publication has been reviewed by security and policy review authorities, is unclassified, and is cleared for public release.

## *Contents*

<i>Chapter</i>		<i>Page</i>
	Disclaimer.....	ii
	Illustrations .....	iv
	Executive Summary.....	v
1	Introduction.....	1
2	Mission and Goals .....	5
3	Roles and Responsibilities .....	9
4	Skills, Knowledge, and Competencies.....	18
5	Enabling Technologies.....	25
	Delivery Systems .....	28
	Development Systems.....	31
	Tracking Systems.....	32
6	Technology Assimilation .....	36
	New Organizational Structures .....	37
	Administrative Support.....	40
	Intellectual Property Regimes .....	42
	Fee-for-Service .....	44
7	Technology Integration.....	47
8	Conclusion.....	58
	Bibliography .....	61

## *Illustrations*

<i>Figure</i>	<i>Page</i>
1-1. The Adaptive Learning Environment Model.....	3
3-1. New Roles for Instructors.....	12
5-1. Personal Information Device.....	30
7-1. The Learning Triad.....	50
7-2. The Parallel Education and Training RMA.....	55

## *Executive Summary*

The Air and Space Force (ASF) of 2025 will be a smaller and far more technical force than even today's Air Force. It will be a matured third wave information age force, incorporating new technologies, new operational concepts, new tactics, and new organizational structures. The advanced weapons of 2025 will require brilliant soldiers, sailors, marines, and airmen. The military of the future will need warriors who are not only comfortable with high-technology equipment but can also deal with diverse people and cultures, tolerate ambiguity, take initiative, ask questions, and even question authority.<sup>1</sup> As a result, the ASF of 2025 will increase its emphasis on education and training to give its warriors the best possible learning opportunities in an effort to make them as productive as possible quickly and economically.

To achieve these goals, the ASF will develop an integrated adaptive learning environment (ALE) centered on four overlapping areas which impact education and training. These areas include the people involved in the learning process along with their changing roles and responsibilities; the evolving goals and objectives of education and training programs; the new skills, knowledge, and competencies required in the information age; and rapidly emerging information systems technologies such as high-capacity global networks, digital knowledge-bases, advanced software, and virtual reality systems.

Education and training in the information age will rely only partly on the application of advanced technologies; the human element will remain the most critical element to

successful information technology integration and exploitation. By 2025, we will see the advent of an educational revolution in military affairs (RMA), reflecting the paradigm shift from “providing instruction” to “producing learning.” Included in the RMA will be incorporation of other fundamental changes in the academic culture, curriculum, and teaching methods.<sup>2</sup>

The integration of technology for ASF education and training will be the key to developing “brilliant warriors.” If successful, technology integration will provide the best education and training possible for ASF personnel, units, and others. It will employ a variety of delivery media to allow learners around the world to engage in education and training activities tailored to their individual needs on demand. It will exploit computer technology to create ultrarealistic simulations that enhance training. It will make vast amounts of information through global networks and digitized libraries available to speed and improve critical decision making. Ultimately, it will harness the tremendous technical power of the information age to educate and train brilliant warriors who are better prepared to fight and win the conflicts of the future.

#### Notes

1. Alvin and Heidi Toffler, *War and Anti-War* (New York: Warner Books, Inc., 1993), 85.

2. Donald A. Norman, “Designing the Future,” *Scientific American*, September 1995, 160.



# Chapter 1

## Introduction

*Computing is not about computers any more. It is about living. . . . We have seen computers move out of giant air-conditioned rooms into closets, then onto desks, and now into our laps and pockets. But this is not the end.*

–Nicholas Negroponte, *Being Digital*

In 1996, we celebrated the 50th birthday of the first electronic computer. Since then computers have progressed rapidly, and recently our lives have been flooded with advances in information technology. Nicholas Negroponte, professor of media technology at MIT, highlights several examples of this phenomenon:

Thirty five percent of American families and 50 percent of American teenagers have a personal computer at home; 30 million people are estimated to be on the Internet; 65 percent of new computers sold worldwide in 1994 were for the home; and 90 percent of those to be sold this year [1995] are expected to have modems or CD-ROM drives. These numbers do not even include the 50 microprocessors in the average 1995 automobile, or the microprocessors in your toaster, thermostat, answering machine, CD player, and greeting cards.<sup>1</sup>

Experts project that these explosive trends in information systems technology will continue. Advances in the next 30 years through both public and private research, development, and production efforts should result in a matured high-capacity global information infrastructure (GII) by 2025. This GI will give virtually everyone

everywhere the possibility to connect to other people, digital libraries, and massive interconnected knowledge bases around the world.

Today, the Air Force is experiencing its own explosion in the use of state-of-the-art information systems. Desktop and laptop computers are proliferating through even more and more offices. Our bases are rapidly expanding their network infrastructures and connecting people into the Internet. We are implementing highly integrated, automated command and control and support systems.

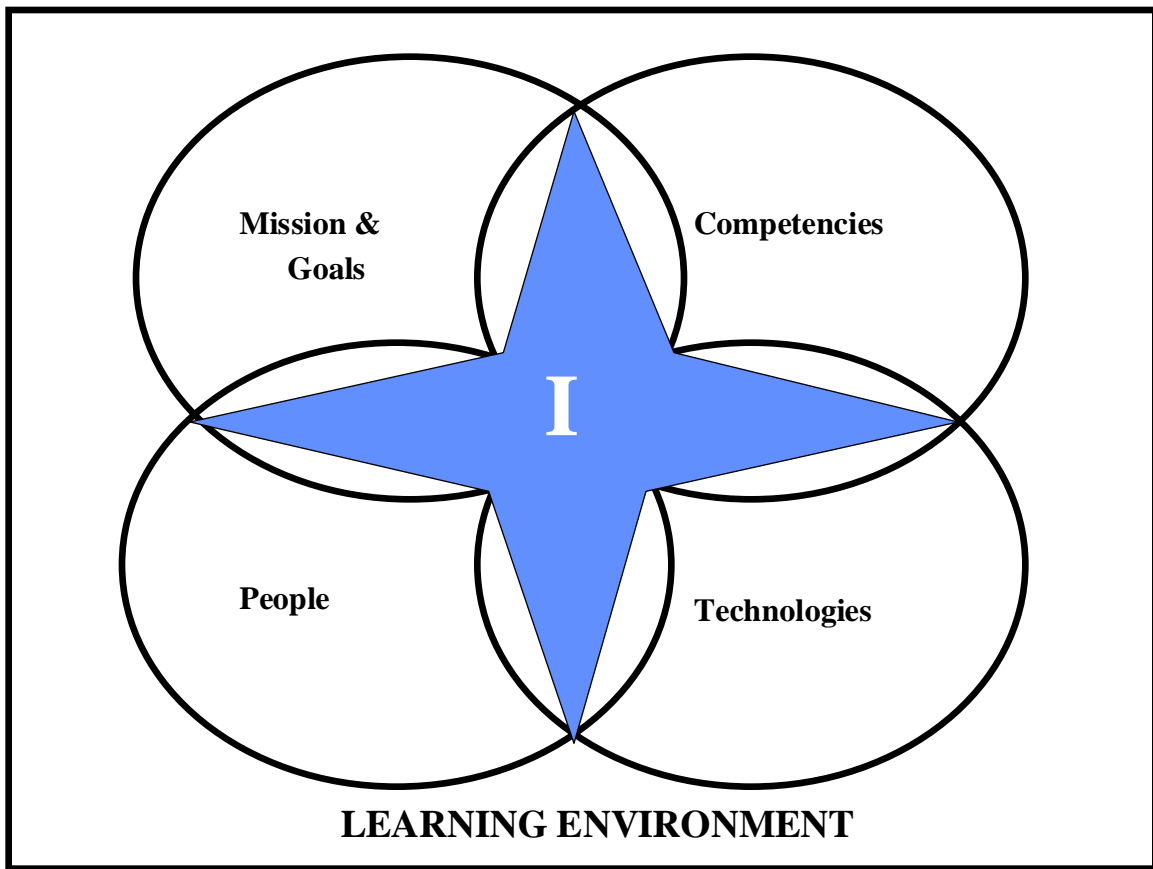
In 2025, the ASF will have to continue to exploit advances in technology to maintain its edge as the world's preeminent air and space power. Undoubtedly it will continue to use hi-tech applications across the force, but as the information age matures, one area will become even more important than before. That area is education and training.

As information becomes the capital commodity of the future,<sup>2</sup> we must ensure our people have the most current information possible about a wealth of topics. As futurists Alvin and Heidi Toffler note, information age "militaries place a massive emphasis on training and education at every level. . . . As in business, learning, de-learning, and re-learning has become a continuous process in every occupational category in the military. Training organizations are rising in the power-pecking order within the various military services. In all branches advanced technologies are being developed to speed learning."<sup>3</sup>

But technology is only one dimension critical to the success of information age education and training. To be effective and efficient in 2025, we must properly integrate technology into our education and training systems to keep us in front of the pack.

This paper examines four critical integration areas which we must consider as we migrate our current education and training systems into an effective ALE of 2025. Those

are (1) the purpose of education and training; (2) the required skills, knowledge, and competencies; (3) the people involved in the learning process; and (4) the technical capabilities and systems used to support it. As figure 1 depicts, integration is the central point at which these elements come together to form a whole. In addition, we will briefly discuss the process we recommend to properly integrate technology in the next 30 years.



**Figure 1-1. The Adaptive Learning Environment Model**

Our thesis is that a change to any one element of the learning environment will impact other elements forcing them to adapt in some way. The net result of all the changes can be a dramatically different learning environment. The process of managing these changes in order to produce the desired ALE is a function of integration.

To analyze the ALE model we first identify the missions and goals of education and training for the ASF of 2025. Next, we address the shifting focus of education and training in the information age and the implications of that shift for the people involved. We then look at expected changes in curricula based on new skills, knowledge, and competencies required in the hi-tech world of 2025. We then discuss future information systems technologies which will impact the ALE and some of the key issues involved in integrating these technologies. Finally, we present a process and some caveats we believe will be useful in helping implement a mature ALE by 2025.

Before we begin these discussions, however, we must identify the key assumptions which shape our concept of the future. These assumptions provide the backdrop from which our discussions proceed. They are as follows:

1. The ASF of 2025 will continue to value, support, and invest in the education and training of its members.
2. The proliferation of global information networks and technologies will be driven by the commercial sector. As the costs of these systems (hardware and software) decrease, they will become both available and affordable for use by the ASF.
3. Information and time will be key commodities of the future for all organizations. Technologies that enhance access to current and accurate information and save time for the user will be incorporated into the learning environment.
4. Technology integration will result in the development of content-independent learning systems that can be accessed by learners in various locations—either at home, at the workplace, or in the field—to satisfy a variety of education and training requirements, thus creating new learning environments.
5. The new learning environments will require new information service infrastructures, protocols and procedures, and support professionals possessing new expertise and skills.

#### Notes

1. Nicholas Negroponte, *Being Digital* (New York: Vantage Books, 1995), 5.
2. John L. Peterson, *The Road to 2015: Profiles of the Future* (Corte Madera, Calif.: Waite Group Press, 1994), 70.
3. Alvin and Heidi Toffler, *War and Anti-War* (New York: Warner Books, 1993), 172.

## Chapter 2

### Mission and Goals

*If we should have to fight, we should do so from the neck up, instead of from the neck down.*

—Jimmy Doolittle

The overall mission of education and training in the Air Force is to leverage the most powerful factor in the warfighting equation—human potential.<sup>1</sup> As we move into the twenty-first century and the information age, it will continue to be people who must fight and win our nation’s wars, and the military must continue to prepare its warriors to accomplish this awesome task. The growing possibility of engagement in nontraditional military missions emphasizes the need for a competently trained and thoroughly educated force prepared to meet a variety of future challenges. It is for this purpose that the ASF of 2025 will continue to value, support, and invest in the education and training of its members.

While military training and education both aim at achieving success in warfare—regardless of the nature or type of conflict—they each have a separate and distinct focus. Training is the process of teaching others specific skills to be performed under defined conditions.<sup>2</sup> It focuses on the psychomotor domain of learning and on performing

specified tasks in specified ways to a predetermined level or standard. Military training, for example, creates competence in using machines and equipment in the appropriate ways; it ensures that people can operate and maintain military systems used to fight wars. Education, on the other hand, focuses on the intellectual or cognitive domain of learning. It is the process of preparing others to solve problems and deal with situations not yet known or defined.<sup>3</sup> It is about learning how to learn and discovering what we do not know so that we may survive in the future. Military education focuses on the art of war and on developing insights and intellectual constructs that ensure we fight our wars smartly; it enables the warrior to envision future threats, engage in creative ways to resolve conflict, select the right tools and methods, and achieve the desired effect.<sup>4</sup>

Although the mission of education and training will remain essentially the same in 2025, new goals will likely evolve as a result of our growing dependence on information. The much-lauded coming of the information age or information revolution brings with it certain assumptions about the future that will impact the learning environment.<sup>5</sup> For example, the growth of information systems technologies will continue to increase the amount of available information and the speed at which it can be transferred. The continued globalization of society, substantial economic growth of multinational organizations, emergence of the knowledge worker,<sup>6</sup> increasing rates of technological advancements, and reliance on space-based assets and global networks are results of the information age. These trends are so significant that information is now considered a center of gravity for the military.<sup>7</sup> And developing “brilliant warriors” capable of success in the information age is becoming a function of education and training.

What are the desired characteristics of the brilliant warrior that can be translated into goals for education and for training? Foremost, brilliant warriors are professionals committed to ASF mission and values. In addition, they are expert in joint, combined, and coalition operations.<sup>8</sup> They are empowered individuals capable of creative problem solving both independently and in collaboration with others; they are able to apply theoretical and analytical knowledge. They have achieved mastery levels of performance and competence within a specialized career field; however, brilliant warriors also embrace change, can rapidly adapt to it, and are willing to take risks. Moreover, they are eager to discover new tools and develop innovative solutions for the problems they face. Finally, these professionals have a good deal of formal education and have acquired a habit of continuous learning.<sup>9</sup> These desired characteristics, when transformed into goals for learning, become the measures of success for education and training in the future. In other words, content and subject areas, learning theories and methodologies, and technologies that enhance the development of these characteristics in our brilliant warriors will be the elements integrated into the ALE of 2025.

Today, our military training institutions appear to be better prepared for their role in the future than are our educational institutions.<sup>10</sup> Military training has remained relevant and repeatedly re-engineered itself to take advantage of new theories of learning and advances in information technology. Our training processes are poised for the future. They are experiential and frequently conducted in realistic contexts using either simulations or real equipment and work-site facilities.<sup>11</sup> There is growing concern, however, that the theory of learning reflected in our current educational programs no longer reflects the needs and practices of our changing environment. Military educational

institutions have been slower to adapt to new insights about how people prefer to learn, slower to incorporate information technology, and reluctant to venture outside their hallowed walls.<sup>12</sup>

However, as we move to the future our brilliant warriors must increasingly merge knowledge and skill to quickly resolve the problems they face; the traditional lines which distinguish education from training will blur. As a result, we must shift our historic focus from separate education and training programs to develop content-independent learning systems and information networks to support them. In the next section we will explore this shift in emphasis and its implications for the people involved in the ALE of 2025.

#### Notes

1. Lt Gen Jay W. Kelley, “Brilliant Warrior” (Unpublished paper, Maxwell AFB, Ala.: Air University, 1996), 1.
2. Lt Gen Charles G. Boyd, briefing to Gen Merrill A. McPeak, CSAF, during the Education and Training Review conducted at the Air Force Wargaming Center, Air University, January 1992. This definition was later expanded upon by Dr John A. Kline, Air University Provost.
3. Dr John A. Kline, “Education and Training Today: Some Differences,” *Air University Review* 36, no. 2 (January-February 1985): 94–95.
4. Kelley, 2.
5. Lt Col Alfred M. Coffman, Jr., “Strategic Environmental Assessment for Modernization Planning,” Report of the Strategic Planning Division, Directorate of Plans, Headquarters United States Air Force, 6 June 1994.
6. Peter F. Drucker, “The Age of Social Transformation,” *Atlantic Monthly* 274, no. 5 (November 1994): 53–80. The term *knowledge worker* refers to the dominant working class of the information age. They replace the industrial workers who were predominant in the industrial age.
7. Coffman, 2.
8. Kelley, 5–6.
9. Drucker, 62.
10. This view is shared by members of the Air University staff and is reflected in General Kelley’s article.
11. Kelley, 1.
12. Ibid.



## Chapter 3

### Roles and Responsibilities

*There is an often-expressed fear that technology will replace teachers. I can say emphatically and unequivocally, IT WON'T. The information highway won't replace or devalue any of the human educational talent needed for the challenges ahead: committed teachers . . . and, of course, diligent students. However, technology will be pivotal in the future role of teachers.*

—Bill Gates, *The Road Ahead*

An article by Robert B. Barr and John Tagg, “From Teaching to Learning,”<sup>1</sup> offers an excellent exploration of education and training paradigms and the impact that changes will have on people interacting in the system. According to these authors, the old—or current paradigm—looks to the institution to provide instruction while the new paradigm expects the institution to produce learning. The shift then is from the instruction paradigm to the learning paradigm, and it requires both a new type of learner and a new type of teacher.

The instruction paradigm takes the means or method—called “instruction” or “teaching”—and makes it the primary purpose of education and training institutions. “To say that the purpose of colleges is to provide instruction is like saying that General Motor’s business is to operate assembly lines or that the purpose of medical care is to fill

hospital beds.”<sup>2</sup> This assumption illustrates the point that the focus should not be on instruction but rather on producing learning with every brilliant warrior. While it may take decades to understand all the future implications of the paradigm shift from providing instruction to producing learning, one goal is evident now. The learning paradigm opens up the truly inspiring goal that each new class of brilliant warriors will learn and know more than the previous class. “In other words, the learning paradigm envisions the institution itself as a learner—over time, it continuously learns how to produce more learning with each graduating class, each entering student.”<sup>3</sup> This concept of the learning organization is truly revolutionary and futuristic. The learning organization and the impact of the new paradigm on the structure of institutions are addressed in more detail later in this paper.

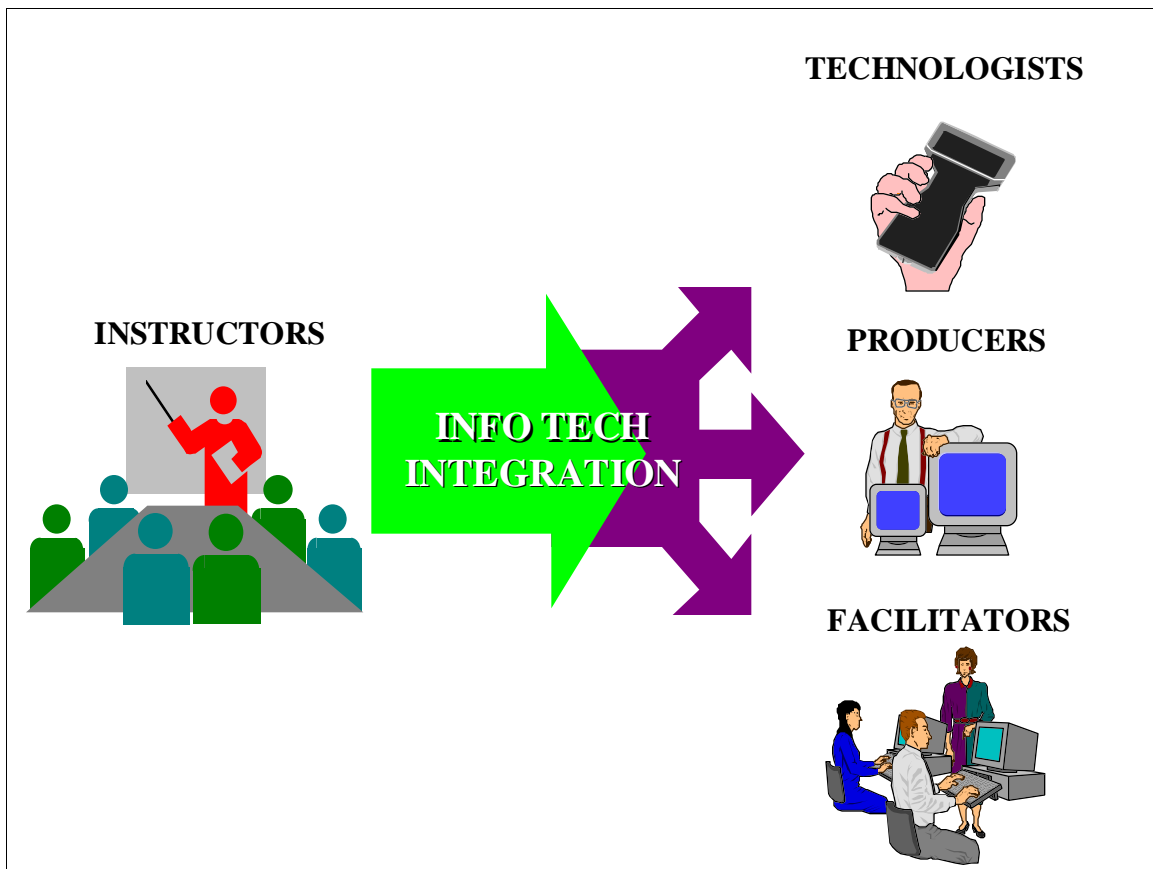
The plan for realizing this paradigm shift by 2025 begins with the understanding of continuing and lifelong learning and the impact of this concept on the individual.<sup>4</sup> Here individuals engage in learning as a lifelong process; adults as well as children participate. Regarding our ASF of 2025, the fact that our brilliant warriors of the future are adults is significant. Educational research has shown that adults are not simply “grown up children.”<sup>5</sup> Traditional methods of pedagogy, the art and science of teaching children, is in many ways different from andragogy, the art and science of teaching adults. Consequently, we must understand andragogy and incorporate its principles into our learning processes if we are to be successful.

Malcolm S. Knowles has given us four assumptions of andragogy.<sup>6</sup> They describe the characteristics of adult learners that have implications for how we should structure the ALE within the ASF. First, adults both desire and enact tendency toward self-

directedness as they mature, though they may be dependent in certain situations. Second, their experiences are a rich resource for learning, and they learn more effectively through experiential techniques of education such as discussion or problem solving. Third, adults are aware of specific learning needs generated by real-life tasks or problems; and adult education programs, therefore, should be organized around “life application” categories and sequenced according to learners’ readiness to learn. And finally, adults are competency-based learners in that they wish to apply newly acquired skills or knowledge to their immediate circumstances and are, therefore, performance-centered in their orientation toward learning. These characteristics help to describe the brilliant warrior and serve as yardsticks for measuring success in the future. In other words, instruction is more likely to be successful in the future if it is responsive to adult needs. Instead of teaching students specific answers to a set curriculum, instruction should help students learn how to ask questions and pursue their own answers.<sup>7</sup> It also should be adaptive to individual goals and learning styles, build on an individual’s prior knowledge, be experiential and realistic, and be applicable to the workplace.

As our perception of the learner’s role changes from a passive model to an active empowered model, we must also consider the changing roles and responsibilities of instructors in the ALE (fig. 3-1). In recent years the terms *facilitator* and *resource person* have developed more favor than “teacher” when discussing adult learning environments. Knowles specified new roles and responsibilities for facilitators that differ from traditional teacher roles—mainly that facilitators do not direct; rather they assist adults to attain a state of self-actualization or to become fully functioning persons. Likewise, resource persons do not direct. They assist adults in locating individuals and

material resources to complete learning efforts that the learners, themselves, have defined.<sup>8</sup> These ideas of Knowles imply that the instructors of 2025 will rarely direct learning. Obviously, some instructor-directed learning will be necessary, given the critical need for uniformity in some aspects of the military.<sup>9</sup> However, as noted above, self-directedness and effective decision-making ability will be characteristics of our future brilliant warriors, and the ALE will offer them the ability to exercise significant self-direction over learning. Moreover, instructors of the future will adapt their role to create the options and opportunities brilliant warriors will need to make good learning choices.



**Figure 3-1. New Roles for Instructors**

Knowles also lists some facilitator traits for andragogy that will become important for future instructors to possess.<sup>10</sup> Faculty must begin to acquire these traits in order for the paradigm shift from teacher to facilitator to occur within the learning environment. First, faculty must establish a physical and psychological climate conducive to learning by creating “a climate of humanness” that encompasses mutual respect among all participants, collaborative modes of learning, and an atmosphere of mutual trust. In addition, faculty must involve learners in mutual planning of methods and curricular directions to the extent possible and involve participants in diagnosing their own learning needs. They must encourage learners to formulate their own learning objectives when appropriate, and encourage learners to identify resources and to devise strategies for using such resources to accomplish these objectives. Then, acting as facilitators, they must help learners to carry out their learning plans and, finally, they must involve learners in evaluating learning, principally through the use of qualitative evaluative modes. These traits of the facilitator will be important for success in the traditional classroom setting as well as in the new global networked environment. They will become criteria by which we judge instructors and instructional systems in the future.

It is clear that these basic fundamental elements of andragogy are the building blocks for the paradigm shift in the roles and responsibilities of instructors, but other skills will be required of the instructor of 2025. Both educators and trainers must better understand the learning process, human motivation, alternative learning strategies, and evaluation techniques. They must understand and implement learning opportunities that enable the achievement of objectives, are situated in a real-world task or simulations, actively engage the learner, accommodate new ideas into prior knowledge, allow learners to

collaborate with others in a conversational, dialogical process, and allow for ample articulation and reflection on the part of the learner.<sup>11</sup> Put another way, instructors must be able to teach knowing-in-action—knowing how to do something as opposed to knowing about something; to stimulate reflection-in-action—the ability to restructure an action based on feedback; and to supervise action research—research based on the practitioner’s application and generation of knowledge in the form of prototypes or models that can be carried over to new practice situations.<sup>12</sup> For example, the development of learning software—the practitioner’s application of knowledge—will be a valued form of academic research for ASF educators and trainers in 2025.

In addition, instructors must leverage information technologies to enhance the learning environment and must be proficient users of classroom technologies and distance learning media. While the availability of smart software, authoring systems, curriculum development models, and media selection aids will enable instructors to manage the instructional systems design (ISD) process,<sup>13</sup> the aids alone will not be enough. Instructors will need to work with production programmers, information technologists, information “gatekeepers,” and other support professionals (discussed in greater detail in the technology assimilation section of this paper) in order to use multimedia technologies and multimode processes in the future. As virtual reality increasingly is used to simulate warfighting environments and techniques, instructors must understand how to “mix Disneyland, Hollywood, and the Silicon Valley,” orchestrate video cameras, and stage-manage special effects.<sup>14</sup> Also, instructors must interact with contractors in the private sector responsible for developing software applications, and they must understand the acquisition process.

To use information technology properly, instructors of 2025 must understand how it supports the learner. David H. Jonassen, professor of Instructional Systems at Penn State University, describes the proper roles of learning technologies necessary if learners are to acquire the survival skills needed for the twenty-first century. Not only must instructors use information technologies as delivery vehicles and controllers of instruction, they should ensure these technologies become facilitators of thinking and knowledge construction in their own right.<sup>15</sup> Instructors must continuously employ the traditional functions of information technology as tools used for accessing information, for representing ideas and communicating with others, and for generating products. And they must begin to see technology as an intellectual partner or mind tool for knowledge construction<sup>16</sup> and as context<sup>17</sup>.

As a mind tool, according to Jonassen, technology must be used for articulating what learners know; for reflecting on what they have learned and how they came to know it; for supporting the internal negotiation of meaning; for constructing personal representations of meaning; and for supporting mindful thinking. Accordingly, instructors must use technology to augment rather than automate human intellect and interaction and to amplify intellectual processes.<sup>18</sup> As context, Jonassen explains that technology must be used for simulating meaningful real-world problems and situations; for representing beliefs, perspectives, arguments, and stories; for defining a controllable problem space for student thinking; and for supporting discourse among a knowledge-building community of learners. Instructors in the future must make certain that technology engages the learner in knowledge construction, not reproduction; conversation, not reception; articulation, not repetition; collaboration, not competition; and reflection, not prescription.<sup>19</sup>

To be successful in the future, our instructors must merge the skills of the human factors engineer, the cognitive psychologist, the information systems technologist, the subject-matter expert, the instructional systems designer, the curriculum developer, the Hollywood director, the mentor and teacher, and the learning resource person. Continuous professional development and increasingly sophisticated curriculum development tools will be the means for learning facilitators to adapt to these changing roles and responsibilities. The ASF of 2025 will embrace structures and vehicles that build professionalism among its instructors, create a supportive working environment, and provide incentives for innovation.<sup>20</sup> In the future, educators and trainers will become active consumers and producers of knowledge and research in order to create a culture of ongoing learning that questions the traditional paradigm.<sup>21</sup>

In addition to changing roles and responsibilities of the people involved with the ALE of 2025, the information age will also challenge the ASF's brilliant warriors to master new subject areas beyond the typical skills and knowledge emphasized in today's education and training programs. These new subject areas are the topic of our next section.

#### Notes

1. Robert B. Barr and John Tagg, "From Teaching to Learning," *Change*, November-December 1995, 13.

2. Ibid.

3. Ibid., 14

4. This notion of lifelong learning originated with the development of continuing higher education or CHE.

5. Lynn B. Burnham, "Teacher Traits That Facilitate Adult Learning," *Education Digest*, March 1983, 32-35.

6. Malcolm S. Knowles, *The Modern Practice of Adult Education: From Pedagogy to Andragogy* (New York: Cambridge Books, 1980), 43-44.

7. Roger C. Schank and Chip Cleary, *Engines for Education* (Hillsdale, N.J.: Lawrence Erlbaum Associates, 1995), 13.

8. Knowles, 44.



9. Stephen Kenney, "Professional Military Education and the Emerging Revolution in Military Affairs" (Unpublished paper of the Science Applications International Corporation), 8.
10. Malcolm S. Knowles and associates, *Andragogy in Action: Applying Modern Principles of Adult Learning* (San Francisco: Jossey-Bass, 1984), 14–18.
11. David H. Jonassen, "Supporting Communities of Learners with Technology: A Vision for Integrating Technology with Learning in Schools," *Educational Technology*, July-August 1995, 60–63. Jonassen discusses the seven qualities of learning as active, collaborative, conversational, reflective, contextualized, intentional, and constructive.
12. Donald A. Schon. "Knowing in Action, The New Scholarship Requires a New Epistemology," *Change*, November-December 1995, 27–34.
13. AFM 136-2234, *Instructional Systems Development*, 1 November 1993.
14. James Der Derian, "Cyber-Deterrence," *Wired*, September 1994, 158.
15. D. H. Jonassen, J. P. Campbell, and M. E. Davidson, "Learning with Media: Restructuring the Debate," *Educational Technology Research and Development* 42, no. 2 (1993): 31–39.
16. Jonassen, 62.
17. Ibid.
18. Linda M. Harasim, *Online Education Perspectives on a New Environment* (New York: Praeger Publishers, 1990), 40.
19. Jonassen, 62.
20. Al Luke, chair, United States Department of Defense Distance Learning Workshop, Report of Special Interest Groups, Conference held at National Defense University, 23–24 March 1994. Participants discussed the need for professional development and organizational incentives in order to stimulate distance learning productivity.
21. Judy Swanson, "Systematic Reform in the Professionalism of Educators," *Phi Delta Kappan*, September 1995, 36–39. Includes a discussion of selected universities engaged in systematic reform.

## Chapter 4

### Skills, Knowledge, and Competencies

*War is a human endeavor, fought by men and women of courage. The machines, the technology, help; but it is the individual's skill and courage that make the crucial difference.*

—Gen Gordon R. Sullivan, *Army Focus*

The ASF of 2025 will incorporate new learning theories into both formal and informal education and training programs—many of which will be customized to accommodate individual learning styles and delivered to the learner at various locations; at home, at the work site, or in the field. Inherent in the approach to learning is the presumption that brilliant warriors will work in new information age organizations as both independent learners and team problem solvers. Not only will the brilliant warriors learn in a greater variety of ways and environments, they will possess certain skills, knowledge, and cognitive processes in order to be comfortable and productive in the information organization. In addition, they must learn new competencies and master new content areas in order for the ASF to meet its goals for education and training.

Several cognitive skills—mental abilities—will be required for both independent and collaborative learning to occur in the era of electronic connectivity and the information age. Brilliant warriors in 2025 must be masters of cyberspace, able to manipulate

networks and hi-tech systems with ease. In addition, they will have to deal with unlimited amounts of information as they communicate and collaborate with others across the global information infrastructure (GII). As a result, brilliant warriors must understand cyber systems and the principles of connectivity. They must also be able to organize, analyze, and synthesize information and recognize the patterns and structures of connections to others. Moreover, they must appreciate and relate to diversity—our potential connections to others. And they must understand and facilitate communications verbally, spatially, and mathematically—the tools to make connections possible.<sup>1</sup> These requirements imply that the military curricula of the future “must cover a range of academic disciplines that includes basic and engineering sciences as well as humanities and the social sciences.”<sup>2</sup>

Future brilliant warriors will combine these cyberspace information skills with required problem-solving cognitive skills such as the ability to apply multiple solutions to a wide-range of problems and analyze detailed feedback; the ability to determine conditions of applicability and nonapplicability based on alternate approaches to each problem; techniques for developing and evaluating alternative courses of action (COAs), and techniques for testing hypotheses. Also the brilliant warrior must develop mental models and communicate the content of those models, including assumptions, and utilize tools and procedures that enhance the retention of information.<sup>3</sup> Based on these requirements we can expect to see more interactive learning, virtual reality simulations, artificial intelligence, smart software, and more theoretical models to evaluate in the future. By 2025, these required skills and processes will be developed and enhanced by

technology-mediated instruction simulators, and smart computers using either education or training scenarios.

In addition to acquiring the above information and problem-solving skills, brilliant warriors will be required to master new metacognitive skills to succeed in the information age. These include such network-related areas as digital literacy, the ability to quickly focus attention on and shift from various visual and auditory stimuli, verbal and nonverbal communications skills for electronic conferencing, dictating skills for voice activated systems, typing (in order to operate left-over equipment using keyboards as input devices), digital graphics development, and netiquette—the etiquette of network conferencing and social interaction.<sup>4</sup> Moreover, brilliant warriors of 2025 will have to master coping and stress reduction skills to keep their cool in the face of information overload. Since the information age will also impact the civilian arena, we anticipate that the public schools of 2025, or their equivalent, will require mastery of these metacognitive skills before our brilliant warriors enter the ASF. If not, however, the organization will use informal means to instill them.

Two other goals of the ASF of 2025, mentioned earlier, will find an enhanced place in the formal curriculum of the future. These are core values and creative thinking. One can expect to see increased emphasis in the curriculum on leadership and ethical behavior, a deeper study of American political and economic systems, more options to study logic, rhetoric, and critical thinking, and improved opportunities for innovation, experimentation, research, and evaluation.<sup>5</sup> Additionally, more emphasis will be placed on the affective learning domain, values clarification, appreciation for right conduct, and professional standards of behavior.

In the future, as is generally the case now, there will be a division of individual learning objectives into four broad categories or competencies—core competencies, functional competencies, assignment specific competencies, and support programs.<sup>6</sup> Although these categories will continue to have broad application in the future, their specific objectives will change based on the changing needs of the ASF. For instance, there will be new core competencies required of brilliant warriors in addition to some of the old ones. Core competencies refer to requirements that are central to professions as a whole and are required for all members of the profession. For example, there are core competencies for all professional military personnel, all acquisition professionals, or all avionics specialists. Mastery of core competencies might be required for entry into a profession, such as areas taught in precommissioning programs or for promotion. The ASF of 2025 will be increasingly concerned with core competencies, and documentation of their mastery will become critical. New core competencies for the future might be developed for content areas such as space and space travel, information warfare, operations other than war, joint and coalition warfare, and the revolution in military affairs.<sup>7</sup>

Functional competencies are career-field specific. Again, some careers will cease to be important in the future as others come into existence or gain in importance. In an effort to ensure competency in the information age, the ASF will increase emphasis on information engineering, human factors engineering, artificial intelligence, and software engineering. Entirely new careers might be uninhabited combat air vehicle (UCAV) operator, information systems technologist, sublethal weapons expert, psychoinformation warrior, and offensive space warrior.<sup>8</sup> In order to be functionally competent, the brilliant

warrior must possess a variety of specified knowledge and skills that are career related. This category is expected to grow in the future as more specialization will be required of personnel.<sup>9</sup>

Assignment specific competencies refer to the knowledge and skills required to do a particular job or to perform a job-specific task. These competencies will depend on the nature and scope of the job and will be taught at the point in time when they are needed. For example, a pilot who becomes a joint campaign planner will be taught—through a computerized individual learning module—how to properly format and develop required joint documents after assignment to the new job where that competency is required. In other words, teaching a skill will occur at the point when it is needed and learning is relevant. Just-in-time education and training, made possible by the widespread availability of expert systems, will be the preferred method to assure assignment specific competencies are met.

Special and support programs are those that are available in the private sector, other government agencies, or civilian academic institutions. These programs will become more important in the future. The brilliant warrior of 2025 must possess advanced academic degrees and professional certifications in order to function as a knowledge worker in the information age.<sup>10</sup> The ASF will use the GII and distributed learning environments to facilitate new collaborative arrangements, consortia, and contract options with numerous agencies, businesses, and institutions around the world to support its brilliant warriors. Even if the traditional role of public institutions of higher education declines,<sup>11</sup> other options will become available through the private sector or through

cooperative worldwide arrangements with business and industry having similar education and training requirements.

As we know more about adult learning and the way individuals interact and synthesize this knowledge with what we know about the mission, goals, and competencies of ASF education and training, we begin to envision the learning environment of the future. Incorporate all this with what we know about the enhanced capabilities of technologies, and we have all the pieces of the puzzle. The next section identifies information technologies that have promise for future education and training and discusses how the ASF of 2025 might use them.

#### Notes

1. Ralph Brauer, "The Internet as School, Or Welcome to Our MUD Room," *Technos* 4, no. 3 (Fall 1995): 14–21.

2. Lt Gen Ervin J. Rokke, "Military Education for the New Age," *Joint Forces Quarterly*, Autumn 1995, 22.

3. Donald A. Smith, Paul J. Sticha, and John E. Morrison, "Soldier as Adaptive Problem Solver" (Paper presented to Roundtable Conference on Military Training and the Potential Revolution in Military Affairs, Fort Monroe, Va., 13–14 December 1995): 6.

4. The term is attributed to Linda M. Harasim, 1991, in *Defense Research Studies* 5, "Conferencing Issues and Decisions," *Learning without Boundaries* (New York: Plenum Press, 1994), 18.

5. Lt Gen Jay W. Kelley, "Brilliant Warrior" (Unpublished paper, Maxwell AFB, Ala.; Air University, 1996), 13–14.

6. James S. McMichael, director, Acquisition, Training and Career Development Policy, The Pentagon, memorandum to John A. Kline, Air University, subject: white paper, The Acquisition Education and Training Program, 15 October 1993.

7. Paul J. Berenson, "Revolution in Military Affairs, Some Implications for 21st Century Army" (Paper distributed to Air War College 2025 participants by the Scientific Advisor to Commanding General, US Army Training and Doctrine Command, 12 May 1994).

8. These technical capabilities, not careers, are referred to by the Air Force Scientific Advisory Board in its report, *New World Vistas; Air and Space Power for the 21st Century: Summary Volume* (1995).

9. Peter F. Drucker, "The Age of Social Transformation," *Atlantic Monthly* 274, no. 5 (November 1994): 68. Although forecasters predict the need for broadly educated personnel, this will not preclude the need for career specialists. Cross-training in two or

more related career fields may be required as the total number of personnel declines. Drucker predicts the need for a highly specialized workforce in the future. Also, the Scientific Advisory Board, *New World Vistas*, discusses the need for highly trained technical personnel.

10. Drucker claims that formal education will be even more important in the future than it is now.

11. Lewis J. Perelman, *School's Out: A Radical New Formula for the Revitalization of America's Educational System* (New York: Avon Books, 1992), 50. Perelman claims that the "social institution commonly thought of as education will be obsolete and ultimately extinct as the dinosaurs."



## Chapter 5

### Enabling Technologies

*We are quickly moving toward the time when anyone can get any kind of information to almost anyone else, anytime. We are also increasingly moving information instead of people. And we're essentially doing it instantly.*

—John L. Peterson, *The Road to 2015*

Experts generally agree that by the year 2025 we will have an information infrastructure available which will provide almost everyone global, high-capacity connectivity at a cost comparable to today's telephone and Internet charges.<sup>1</sup> At the end of this powerful infrastructure, we will have low-cost personal information devices (PIDs) which will give us integrated voice, video, and data capability in a package smaller than today's notebook computers.<sup>2</sup> Moreover, these PIDs will have computing power and speed virtually equivalent to the human brain<sup>3</sup> and will have access to massive knowledge bases around the world. All these capabilities combined have the potential to significantly alter the way people learn in the ASF. Shortly we will examine the specific technologies which promise the capabilities we have described. First, however, let us imagine the learning available to us in a world of micro-supercomputers and worldwide connectivity.

First, we'll look at a young laser radar technician in the field in 2025. Engineers have just developed a new modification to the system he's responsible to operate and maintain. Instead of sending him back to Keesler Air Force Base for supplemental training, the engineers work with educational experts to develop a virtual training module for this modification. Immediately before they upgrade the radar system, they electronically transmit this training module to all the field units and technicians affected by this change. Then our technician, using his PID hooked to virtual reality viewers and gloves, will work through this multimedia training module. The module gives him all the information he needs about the upgrade along with a simulation which allows him to practice new operational and maintenance procedures until he has achieved mastery. In addition, the training module will be able to answer questions the technicians have about the new procedures, and for any questions that stump the training module, the technicians will have immediate access to system experts either through E-mail or a video phone call. In this case system experts and educational specialists can provide just-in-time, system wide training without the expense of temporary duty trips or full-time classroom instructors.

Next, we'll look at a young major enrolled in joint professional military education (PME). Her seminar mates are scattered across the country, and several times each week they converge in a video teleconference to discuss PME topics with their faculty leader. All their lesson materials come to them through electronic media. A typical leadership lesson, for example, would have extracts of classic leadership texts for them to read along with clips from classic films on that leadership topic and lectures from leadership experts and senior military/civilian leaders for them to watch. When they "meet" to discuss this lesson, their faculty leader has instant access to any of this material, all of it digitized, to

emphasize key points and clarify any confusion. Then after the lesson, the leader can electronically administer a test to see how well the students have mastered the material. With instantaneous feedback, the leader can quickly correct any problem areas revealed through the test. For research, these PME students have at their immediate disposal a wide-range of government, university, and commercial knowledge bases available through their PID and the electronic network; they are not limited to the base library. They can research their paper, write it, and submit it electronically without ever having to leave their base. And if they have any questions, they will have quick access to their seminar mates and their faculty leader. In this scenario, the virtual seminar offers many of the benefits of the current residential program. An effective distance learning program such as this could significantly reduce the need for an in-residence version of PME.

Finally, let's examine two pilots from separate units who are training to fly a mission together. They each connect their PID to one of their unit's personal simulator kits and then hookup to each other via the multilevel secure network. Their simulation program is downloaded and synchronized so they can simulate flying their unmanned aerial vehicle (UAV) training mission together at their respective home bases. In addition, the simulation program has been automatically updated in a matter of minutes with the latest real-time intelligence, reconnaissance, weather, and mission planning information. As a result, these pilots can fly this simulated training flight under conditions as close as possible to their upcoming mission. During the simulation, the fidelity of the virtual reality program allows the pilots to experience the sortie as a real two-ship UAV formation. Each action by one pilot immediately registers a realistic change in the second pilot's simulated environment. At the end of the training flight, the pilots have actually

experienced flying together in conditions virtually identical to those they will face in their actual mission.

These scenarios are typical of the types of training and education we conduct in the armed forces today and will likely need past 2025. Common to them is the fact that by 2025 our brilliant warriors will be able to conduct most of their learning without having to undergo expensive temporary duty trips. Multipurpose PIDs and miniaturized virtual reality systems will obviate the need for expensive stand-alone simulators at each operational location. The GII will instantly connect learners with the people and information they need no matter where they are.

With that backdrop, we will now discuss the kinds of information systems technologies that promise us such immense capabilities by 2025. We'll group these technologies according to the three general types of functions that they will serve in the ASF's ALE. Categories include delivery systems which allow the learner to access information, simulations, teleconferences, or other learning products; development systems which allow education/training technologists,<sup>4</sup> facilitators, supervisors and others the capability to develop effective learning programs and services; and tracking systems which allow commanders, individual learners, supervisors, and personnel specialists to manage learning requirements and progress.

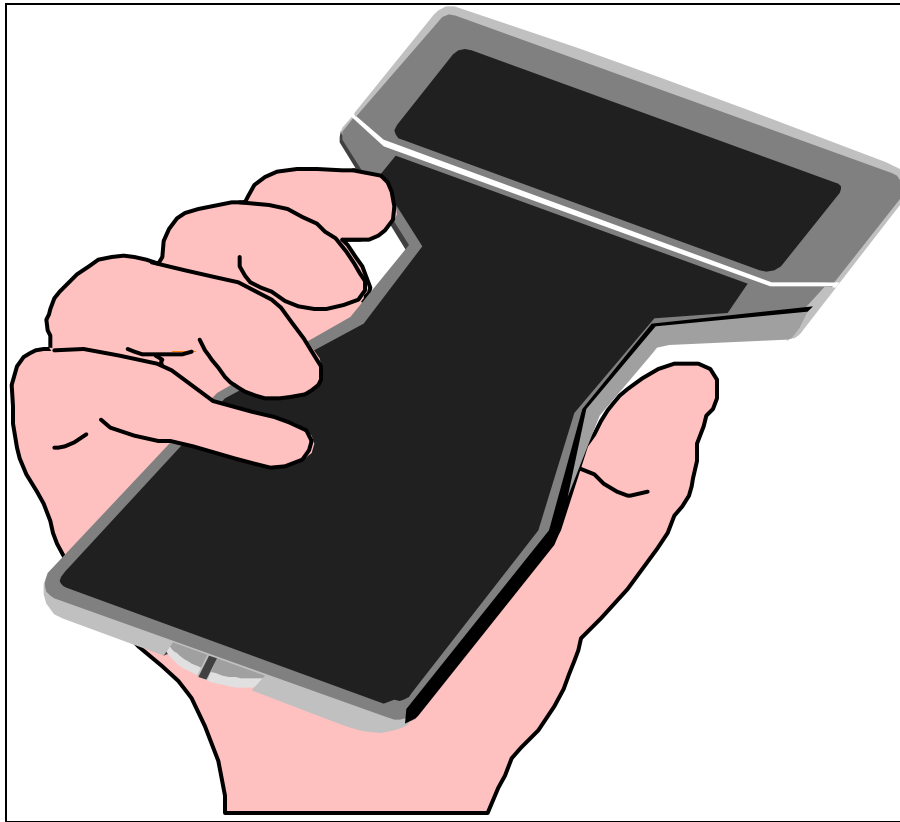
### **Delivery Systems**

Advances in information systems are occurring at such a rapid rate that we see a new generation of technology every 18 to 24 months. With this rapid advancement, even major progress becomes evolutionary instead of revolutionary. In our 2025 project,

we've been told to think in terms of double leap advances. In the information systems arena, however, it's probably more appropriate to think in terms of quick "hops" instead of "leaps." If we conservatively project current advances over the next 30 years, we should progress at least 15 hops in information systems technology beyond where we are today. Experts generally agree that the seeds of 15-hop progress are strongly rooted in today's emerging technologies. Advanced networking technologies such as matured fiber optic links,<sup>5</sup> and new/improved high-capacity commercial satellite constellations (including geostationary and low-earth-orbit systems)<sup>6</sup> with laser links<sup>7</sup> will give almost everyone the possibility for low-cost access to the worldwide high-capacity information infrastructure—the GII. Moreover, new data/video compression techniques<sup>8</sup> will allow us to transmit huge amounts of information across this infrastructure with amazing efficiency. In just the last five years, we've been able to reduce the bandwidth required for high-quality video from around 45 million bits per second to just 1.2 million bits per second.<sup>9</sup> In 30 years, further advances in compression and bandwidth capabilities will allow us to deliver enormous amounts of information through the GII very quickly, cheaply, and reliably.

At the end of this massive GII will be incredibly powerful end-user devices and embedded microprocessors which will enable both individuals and groups of learners to access the capabilities of the adaptive learning environment (ALE). Nanotechnology<sup>10</sup> and microelectromechanics<sup>11</sup> promise us high-speed, multipurpose PIDs which will cost about the same as current desktop computers and have a computing capability roughly equivalent to the human brain! In addition, these PIDs will come in small packages—small enough to hold in a hand or wear on the arm (fig 5-1).<sup>12</sup> They will also have

wireless connections to other user devices such as wall-mounted high-definition video screens, speakers, and virtual reality simulation devices. In addition to supercomputing PIDs, peripheral devices and other objects (e.g., doors, furniture, appliances, etc.) will also be widely computerized with powerful imbedded microprocessors which will be able to interact with the PIDs to enhance network information.<sup>13</sup> Explosions in virtual reality hardware/firmware,<sup>14</sup> TV technology, and other similar devices are already giving us a preview of the incredible hi-tech possibilities which will be an everyday reality by 2025.



**Figure 5-1. Personal Information Device**

## Development Systems

Obviously sophisticated software will be an integral part of the delivery systems available by 2025. Moreover, software will play a critical role in the development systems used to produce ALE materials in 2025. Advances in fuzzy logic/neural networks<sup>15</sup> will give us smart software systems which will allow PIDs to serve as automated assistants for humans. These will help education/training technologists to design better software systems and provide high-fidelity simulations tailored for a wide variety of education and training scenarios.<sup>16</sup> In addition, similar software will help keep track of learners' needs and preferences. These information age assistants, which Nicholas Negroponte calls "digital butlers"<sup>17</sup> will then be able to search various sources across the GII to compile the right information in the right format for the learner on demand.

In other areas, voice recognition systems, automated language translators, and similar software systems<sup>18</sup> will allow people of different countries to communicate with ease and without the use of a keyboard. This will greatly enhance the quality and ease of combined training with one or multiple allies. In addition, multilevel security (MLS) software systems coupled with low-cost personal identification systems (e.g., fingerprint, retinal scan, deoxyribonucleic acid [DNA] identification devices, etc.) will provide the security necessary to allow learners to use the ALE and GII with confidence.<sup>19</sup>

Other related technical advances will enhance software development to spur very efficient and effective ALE methods and materials. Advances in visualization technology will enhance the three-dimensional aspect of virtual reality simulations and other educational presentations.<sup>20</sup> Developments in what Lewis J. Perelman calls "brain

technology”<sup>21</sup> will not only help software developers, both human and automated, to build better educational systems but also will allow enhanced learning to take place from the inside out. For example, advances in cognitive science, human factors engineering and biochemical technology are already spawning promising developments in “new computer technology that mixes organic and inorganic elements,”<sup>22</sup> more effective human-machine interfaces, the inclusion of emotional elements in simulation models, and brain-enhancing chemicals. By 2025 these developments, combined with access to numerous knowledge bases available worldwide, should allow the ASF to acquire and/or develop a wide-range of ALE products and services designed to improve the thinking and learning skills of our brilliant warriors. These will range from simple education/training presentations to extremely challenging, high-fidelity simulations, all tailored to each learner’s, or unit’s, need deliverable anywhere on demand.

### **Tracking Systems**

Despite enormous advancements in the GII and systems development capabilities, the ASF of 2025 will still need to know the status of its members’ training and education. Fortunately the advances noted above in both delivery and development systems will enhance the ASF’s efforts in this area, too. Advances in cognitive science, smart software, and human factors engineering will give us sophisticated aptitude, achievement, and preference evaluation tools. These will allow the ASF to accurately select and channel its brilliant warriors into career areas best matched to both them and organizational needs. These advanced evaluation tools will then help ASF personnel experts establish learning goals for each new brilliant warrior. From this point, the ALE



will automatically update individual records once a member has accomplished a learning task. This information will be stored in integrated corporate knowledge bases accessible to authorized members.

Because multiple options and parallel scenarios will exist, the ASF will embrace a flexible ALE management structure consisting of on-line enrollment and tracking systems that interface with personnel records and readiness information. The system will enable any student or training manager from any location to access data through a PID on the student's career path, individualized learning plan, and corresponding educational/training requirements. The student or trainer will be able to see which core competencies and proficiencies have been mastered to date, levels of readiness, and remaining deficiencies. The database will display available learning options, time frames for completion, and other pertinent information. Individuals will be able to select the appropriate programs, courses, and formats—whether resident or distance learning, individualized or supervised, at home, on-the-job, or in the school house, etc., and instantaneously enroll. Upon enrollment, the system will trigger the appropriate response—whether to process temporary duty instructions, or to activate instructional delivery in the appropriate distance learning format to the individual or training supervisor, at the appropriate place and time. As individual brilliant warriors successfully complete their learning objectives, the tracking system will automatically update the appropriate records.

Virtually all of the information technologies described above are already emerging from the hi-tech laboratory into the marketplace. We don't know exactly what products will emerge, because specific predictions in this dynamic arena are difficult. As Joel Swerdlow notes, "To know where information technologies are taking us is impossible.

The law of unintended consequences governs all technical revolutions.”<sup>23</sup> Regardless of the exact nature of future systems and devices, by 2025 our brilliant warriors everywhere should be harvesting the mature fruits of the continued explosion in hi-tech capabilities. However, these technologies present us with not only tremendous opportunities but also with some daunting challenges which the ASF must overcome to create a well-integrated ALE in 2025. The next section discusses these challenges.

### Notes

1. John L. Peterson, *The Road to 2015: Profiles of the Future* (Madera, Calif.: Waite Group Press, 1994), 30.
2. *Ibid.*, 59–60.
3. Lewis J. Perelman, *School's Out: A Radical New Formula for the Revitalization of America's Educational System* (New York: Avon Books, 1992), 29–31.
4. USAF Scientific Advisory Board, *New World Vistas: Air and Space Power for the 21<sup>st</sup> Century* (unpublished draft, the human systems and biotechnology volume, 15 December 1995), 18.
5. Jack M. Sipress, “Undersea Communications Technology,” *AT&T Technical Journal*, January-February 1995, 4–7. Undersea advances are also discussed in the following: “Undersea Cable Upgrades Proven Feasible,” *AT&T Technical Journal*, January-February 1995, 2–3; and Peterson, 35–36.
6. Peterson, 190–91.
7. USAF Scientific Advisory Board, *New World Vistas: Air and Space Power for the 21<sup>st</sup> Century*, summary volume (Washington, D.C.: USAF Scientific Advisory Board, 15 December 1995), 20.
8. Otis Port, “Sifting through Data with a Neural Net,” *Business Week*, 30 October 1995, 70.
9. Nicholas Negroponte, *Being Digital* (New York: Vantage Books, 1995), 17.
10. Ed Regis, “It’s a Small, Small World,” *Reason*, December 1995, 28–34. Additional aspects of nanotechnology are discussed in “Artisans of the Tiny,” *The Economist*, 30 September 1995, 97–98; and “Quantum Caverns: A Thousand Points of Light,” *AT&T Technical Journal*, January-February 1995, 3.
11. Richard Lipkin, “Teeny-weeny Transistors,” *Science News*, 6 May 1995, 287.
12. Perelman, 36.
13. *Ibid.*, 27–28.
14. Jane Ellen Stevens, “The Growing Reality of Virtual Reality,” *BioScience*, July-August 1995, 435–39. Additional information on the rapidly expanding world of virtual reality is in “Virtual Reality for Soldiers,” *The Futurists*, November-December 1995, 44; and Steven A. Booth, “Hot Stuff Eye Candy,” *Rolling Stone*, 10 August 1995, 66.
15. Perelman, 31–33.

16. Dee Howard Andrews, Lynn A. Carrol, and Herbert H. Bell, "The Future of Selective Fidelity in Training Devices," *Educational Technology*, November-December 1995, 32–36.
17. Negroponte, 150–52.
18. Peterson, 64–66. Perelman, 33–34, also discusses these advanced capabilities.
19. Institute for National Strategic Studies, *Strategic Assessment 1995* (Washington, D.C.: Government Printing Office, 1995), 153.
20. Perelman, 39–41. Three-D presentations are also discussed in Clarence A. Robinson, Jr., "Virtual Teleconferencing Spurs Factory, Medical Collaboration," *Signal*, April 1995, 15–18.
21. Perelman, 44.
22. *Ibid.*, 44–47.
23. Joel L. Swerdlow, "Information Revolution," *National Geographic* 188, no. 4 (October 1995): 5.

## Chapter 6

### Technology Assimilation

*Constructing an information organization requires a new moral vision of what it means to be a member of an organization and a revised social contract that combines members of a firm together in ways radically different from those of the past.*

—Shoshana Zuboff

In their article, “Scholarly Communication, Academic Libraries, and Technology,” authors Richard Eckman and Richard Quandt emphasize that the mere existence of hardware and software does not give direction to future implementation of technology.<sup>1</sup> We must seriously consider how to direct technology to successfully integrate it for our ASF purposes in 2025. Three areas are of particular concern. First, effective technology integration will drive the decentralization of academic institutions and create new infrastructures which, in turn, will generate new roles for support personnel, publishers, scholars, and librarians.<sup>2</sup> Second, advanced technologies will allow easy modification and tailoring of previously distributed information and educational works; but it will also create the need for effective mechanisms to authenticate and protect the integrity and academic quality of such works. Third, technology integration will intensify the need to

account for the revenue interests of commercial information vendors in order to protect intellectual property rights. Below we will examine each of these issues in greater detail.

### **New Organizational Structures**

As the ASF integrates information technology across its many functions and organizations, brilliant warriors at all levels will gain unprecedented access to computing and information resources. If used correctly, these resources could generate increased efficiencies that will give our military the competitive edge needed for survival through the twenty-first century. Consequently, the ASF of 2025 will require all its members to manage complex information and use it to create value for their individual organizations.<sup>3</sup> To this end, the force will empower users at all echelons to make decisions traditionally reserved for higher bureaucratic and supervisory layers. New flat information age organizational structures will emerge as the norm by 2025. Bill Gates, the chairman and CEO of Microsoft Corporation, describes what is likely to happen to organizations as they enter the information age.

Information technology will affect much more than the physical location and supervision of employees. The very nature of almost every business organization will have to be reexamined. This should include its structure and the balance between inside, full-time staff and outside consultants and firms. . . . If communication systems are good enough, companies don't need as many levels of management. Intermediaries in middle management, who once passed information up and down the chain of command, already aren't as important today as they once were.<sup>4</sup>

Already the military functions as a flat, decentralized organization during war.<sup>5</sup> This trend will continue as the use of advanced information technologies makes command and control and intelligence information readily available throughout the force. And the

increased use of technology to successfully support flat wartime operations will transfer to peacetime operations as the GII matures. The mission-oriented orders of wartime—which allow leaders and soldiers in the field to interpret information and make decisions based on commander’s intent—will extend to other operations. By 2025, the ASF will have a new mission-oriented organizational structure which empowers brilliant warriors throughout the force to know and do more. Newly energized and reorganized learning institutions will emerge in 2025 to meet the challenges of the information age and the postulated revolution in military affairs (RMA) that will result.<sup>6</sup> The concept of the RMA is explained in chapter seven of this paper.

In 2025, the ASF learning institutions, like many civilian academic institutions, will be transformed from large centralized campuses to dispersed information and service network channels.<sup>7</sup> Residence requirements will diminish as distance learning opportunities grow. Increasingly, schools will deliver learning materials to students via the network. Technology will permit professors and educators to telecommute their services to students in ways that de-emphasize traditional academic physical and bureaucratic infrastructures in favor of widely distributed environments. Students will identify a school not by a distinct location, campus, or building, but rather by a brand or franchise of network media through which they access services and courses.<sup>8</sup>

Advancements in distance learning technologies are beginning to create new education and training infrastructures within the military.<sup>9</sup> Although distance learning has existed for decades in the form of printed correspondence courses or videotaped programs, these traditional methods did little to transform the classroom. Traditional distance learning activities were seen as passive and not on par with active, face-to-face

instruction delivered in the seminar environment. Often instruction became obsolete in the months it took to produce and distribute the courses. But new interactive technologies make real-time interaction and feedback possible, enable large audiences to participate, and provide quality instruction. In fact, evaluations have shown that when appropriate media are used, distance learning is at least as effective as resident instruction.<sup>10</sup> Technology will continue to reduce the need for students to travel great distances at great expense to attend courses in residence. Instead, students increasingly will come together in virtual residence. However, this does not mean that the traditional classroom, or campus, will become completely obsolete.

In the military context, the mission of the ASF of 2025 will dictate that the service retain control, standardization, and uniformity over many aspects of education and training of its brilliant warriors. Consequently, education and training technologists will incorporate standardized material into learning products. In addition, the military's unique requirements for cohesiveness, team camaraderie, and physical fitness will drive retention of some standardized residence programs. For instance, accessions education, initial unit and skills training, some leadership and professional quality development, and core values education will be conducted via resident programs which incorporate numerous hi-tech learning tools. Although scaled down significantly, the modernized schoolhouse, with the necessary administrative component and infrastructure, will continue to exist to provide standardized resident learning opportunities.

## **Administrative Support**

As much as things will change by 2025, some areas will remain constant—such as the need for administrative support. The integrated hi-tech development, delivery and tracking systems which make up the revolutionary adaptive learning environment will create the need for an administrative infrastructure consisting of network librarians or “gatekeepers” who will manage academic programmatic issues, negotiate site licenses, and help users navigate through the information superhighway.<sup>11</sup> These gatekeepers will make extensive use of automated assistants to manage information spread across a widely distributed world of academic communications. The automated assistants will scan virtual libraries, select information, and build lesson plans or packages according to established end-user or instructor priorities. Gatekeepers will help instructors and students manage information in ways that best meet their learning objectives.

Additionally, in 2025, the ASF will need specialized personnel to ensure that brilliant warriors receive broadcast-quality learning materials. These production programmers, drawn from the communications and marketing (television, film, etc.) disciplines, will be expert in “edutainment”<sup>12</sup> and will help instructors develop multimedia presentations that maintain the attention and interest of learners. By 2025 these highly skilled professionals will be able to access sophisticated, commercial-quality digital production capabilities in order to create dazzling learning products for our brilliant warriors.

Advanced systems management processes will also be in place by 2025 to help education technologists, instructors, and students use learning systems more efficiently. In an effort to control the cost of information exchanges, to prevent overload on individuals and networks, and to ensure the privacy of its members, organizations of 2025



will establish new procedures, invoke new protocols, and implement smart software agents. On-line systems will be in place that will guide both producers and users of ALE materials to the most efficient communications medium based on the purpose of the interaction.<sup>13</sup>

Decision-aids and software agents will help instructors identify the best method of transmission to accomplish desired tasks based on educational, environmental, economic, and other limitations. For example, the system will guide them away from satellite-delivered, full-motion video teleconferencing, if on-line computer conferencing will accomplish the task at a lower cost. Likewise, the system will guide instructors away from synchronous voice transmissions if asynchronous data transmissions would accomplish the task. Also, brilliant warriors at all levels will be able to activate on-line filters to prevent unwanted message traffic and to instantaneously sort incoming messages based on a user-established set of protocols and priorities. All voice activated systems as well as E-mail systems will have caller identification (ID) features and a full-range of systems-generated answering services to scan and screen messages and activate automatic replies. Nicholas Negroponte describes the type of editing systems that will be available in the future in his book, *Being Digital*.

The answer lies in creating computers to filter, sort, prioritize, and manage multimedia on our behalf—computers that read newspapers and look at television for us, and act as editors when we ask them to do so. This kind of intelligence can live in two different places. It can live . . . at the transmitter and behave as if you had your own staff writers . . . or in the receiver...depending on your interests, habits or plans for the day. The future will not be one or the other, but both.<sup>14</sup>

## **Intellectual Property Regimes**

As discussed above, the delivery systems available in 2025 will allow brilliant warriors to access immense amounts of information from virtually infinite sources through the GII. This wide-open access to information presents profound implications for information integrity, and the ASF of 2025 will have to provide mechanisms to guarantee the academic integrity of the materials it makes available over the net. Likewise, the force must protect the interests of its members who publish over the net. The former will be aided by the academic accreditation process; the latter by the enactment of commercial copyright laws appropriate to cyberspace.

The Southern Association of Colleges and Schools (SACS) has taken the lead in establishing standards and criteria for academic institutions offering distance learning courses and programs. These criteria are intended to ensure the quality of the overall academic programs delivered through networks and other distance learning media. They require adequate planning, systematic evaluation of instructional results, processes for monitoring curriculum changes, provisions for student support services, and appropriate orientation and evaluation of faculty using the distance learning systems.<sup>15</sup> The ASF of 2025 will need to work with the SACS or other accrediting agencies to ensure that its academic programs meet all applicable standards for distributed learning materials. Only in this way will the brilliant warriors of the future, who may never come face-to-face with an instructor, know they are receiving quality and timely information over the GII.

Through the GII, education technologists and brilliant warriors will use digitized virtual libraries consisting of works converted into and created in electronic format.<sup>16</sup> These virtual libraries will provide access to the intellectual and cultural information and

knowledge people need in order to learn, work, and prosper.<sup>17</sup> Yet the potential of this integrated network of learning resources will not be realized if the informational, educational, and entertainment products protectable by intellectual property laws are not effectively safeguarded when made available over the GII.

The ASF will get help in this endeavor to authenticate and protect the intellectual products of its members by the private and commercial sectors. Publishers, for example, are very concerned about the ease with which electronic publications can be copied and shared. Publishers bring risk capital to bear when they recognize the need for new publications and can bring economies of scale to the development of the virtual libraries. But these owners of intellectual property rights will not be willing to put their interests at risk if systems are not in place that protect their interests. Because their survival depends on the revenue stream which depends on copyright protection, publishers' property rights must be protected before they will make large investments in the digitization and distribution of data over the network. Therefore in the integrated information technology environment of 2025, a new intellectual property regime must exist that will protect the legitimate rights and commercial expectations of people and organizations who create works for use over the GII. Users must have the broadest possible access to the widest variety of music, literature, art, dance, and film on terms that, in the language of the Constitution of the United States, "promote the Progress of Science and useful Arts."<sup>18</sup> To get there, timely adaptation of intellectual property laws to respond to technological advances will be necessary to serve copyright owners and to ensure that the body of creative works available over the GII continues to grow.

## **Fee-for-Service**

In line with intellectual property protection, integration regimes of 2025 will include provisions for fee-setting, licensing, and payments for use of copyrighted materials. Information will be a primary commodity of the future in the new information economy. While most information exchanged over the Internet is free today, that will change in the future. First, as commercial providers continue to expand their networks and service offerings, they will also develop new marketing schemes and tariff structures to attract users.<sup>19</sup> Instead of subscribing to a single carrier for service, multiple options, and variable rates will be available to the user. Users will be able to choose a carrier in real-time and on demand for each individual transmission based on the most favorable rate. Users will access the network and transfer payment in the same transaction. Second, experts who offer their expertise and services through these systems (e.g., those who deliver lectures over conferencing systems) will charge honoraria and consulting fees.

Also, digital publishing houses will establish copyright, intellectual property, and licensing fees for digital publications accessed over the networks. Monetary transactions will occur over the networks in a real-time, fee-for-service basis as payment-for-data exchanges with authors, publishing houses, and experts occurs.<sup>20</sup> New budget and on-time accounting systems will be necessary. In the final analysis, publishers and information providers in 2025 will make use of innovative technology as well as tried and true legal devices such as licensing agreements and contracts to regulate information use and to prevent unauthorized access to data by nonpaying parties.

Now that we've discussed each of the four elements which influence the future ALE, we will turn to a brief discussion of how we believe we should get there in 2025. We will

examine a few suggestions for effectively integrating technology and some caveats which we must keep in mind as we proceed.

#### Notes

1. Richard Eckman and Richard Quandt, "Scholarly Communication, Academic Libraries, and Technology," *Change*, January-February 1995, 40.

2. *Ibid.*, 43.

3. Shoshana Zuboff, "The Emperor's New Workplace," *Scientific American*, September 1995, 164.

4. Bill Gates, *The Road Ahead* (New York: Penguin Books, 1995), 153.

5. Communications platforms enable theater commanders to link directly with the national command authorities.

6. Educators and trainers currently are discussing the implications of the revolution in military affairs for education and training organizations and the structure of institutions. This subject was debated at a conference sponsored by the Office of the Secretary of Defense (Net Assessment) at US Army TRADOC, Fort Monroe, Va., 13–14 December 1995.

7. Lewis J. Perelman, *School's Out: A Radical New Formula for the Revitalization of America's Educational System* (New York: Avon Books, 1992), 57.

8. *Ibid.*

9. Distance learning environments for the Air Force are described in "Curriculum Analysis and Media Selection Guide" (Paper prepared by the Distance Learning Working Group, Maxwell AFB, Ala.: Air University, 4 February 1994). Distance learning programs for the Army are described in the Army Science Board Study, "Distance Learning: The Continuing Evolution of the Digital Army Classroom," prepared by the Information Technology Laboratory, USAE Waterways Experiment Station, 5 October 1994.

10. Adelaide Cherry and Phillip Westfall. Briefing to Air University commander on status of distance learning programs at Air University, Maxwell AFB, Ala., Headquarters Air University, Plans Division, August 1994.

11. Paul Metz, "The View from the University Library," *Change*, January-February 1995, 33.

12. Cyndee Miller, "Software That's Fun and Educational—That's 'Edutainment'," *Marketing News* 27, no. 9 (26 April 1993), 2.

13. Air Force Modernization Planning, AETC Education Mission Area Plan, AETC/XORE, 19 July 1995. The Mission Area Plan (MAP) describes deficiencies and proposed solutions for education. The Education and Training Management System (ETMS), a system currently under development, will possess some of the attributes mentioned in this section.

14. Nicholas Negroponte, *Being Digital* (New York: Vantage Books, 1995), 20.

15. Southern Association of Colleges and Schools, "Policies, Procedures, and Guidelines of the Commission on Colleges" (Decatur, Ga., 1992).

16. *Comments on the Draft Report of the Working Group of Intellectual Property Rights*, US Copyright Office, September 1994, 29.

17. *Intellectual Property and the NII*, Draft Report of the Working Group of Intellectual Property Rights, July 1994, 6.

18. Congress's authority to grant intellectual property right is derived from the US Constitution art. 1, sec. 8, clause 8.

19. G. A. Redding and J. D. Fletcher, "Technical and Administrative Issues in Distributed Training Technology," in Robert J Seidel and Paul R. Chatelier, ed. *Learning without Boundaries, Technology to Support Distance/Distributed Learning*, Defense Research Series 5 (New York: Plenum Press, 1994), 85–86.

20. Hal Varian, "The Information Economy," *Scientific American*, September 1995, 161–62.

## Chapter 7

### Technology Integration

*My God, if there was anything that helped us get through those eight years, it was plebe year. And if there was anything that screwed up that war, it was computers.*

—Vice Adm James B. Stockdale

Today, the Air Force has already begun its process of integrating information systems technology into its activities. Some Air Force functional areas, such as command and control and intelligence enjoy significant benefits of advanced computer systems and wideband connectivity. Others have barely begun. In the education and training arena, we have started to implement a satellite distance learning network, and we are upgrading many of our correspondence courses with multimedia capabilities. However, we have a long way to go before we arrive at a mature ALE, so as we proceed along our integration journey, we would be wise to learn some “how to” guidelines for technology integration derived from academic and civilian organizations. There is a growing body of information in this area as more and more organizations are trying to integrate technologies into their operations. They are learning what to do and what not to do. We should glean all we can from their experiences.

The first guideline comes from education and technology experts Kenneth Green and Steven Gilbert. They suggest that effective technology integration should occur over the course of several years in a well-considered implementation cycle.<sup>1</sup> The first stage of this cycle involves some planning, investigation, and experimentation. During this stage the organization recognizes that some of its people can work better/faster using computers, and it allows small groups to proceed.

The second stage is characterized by frustration. Here the organization marks a few years of planned capital investment in technology. The results are often surprising increases in operating expenses with little reduction in other areas. They also experience significant, unexpected delays in implementing even the most obvious applications.

Stage three involves a few years of readjustment where costs and annual investments in technology stabilize while capacity continues to grow and new functions develop. (Or, the organization rejects “automation” and/or leaves the business that was being automated.)

Finally, in the last stage, the organization achieves new levels of efficiency and effectiveness as a result of its technology investments. In this stage the organization is no longer pursuing its old objectives or working in old ways, because technology has driven it to alter many of its core business processes.

At the end of this cycle we find that the successful integration of information technologies is almost always associated with significant structural change—the kind of change that educational institutions routinely resist. Often budget limitations and school traditions are the cause of this resistance in civilian education institutions, and these in turn fuel two basic problems in technology integration. Green and Gilbert emphasize that



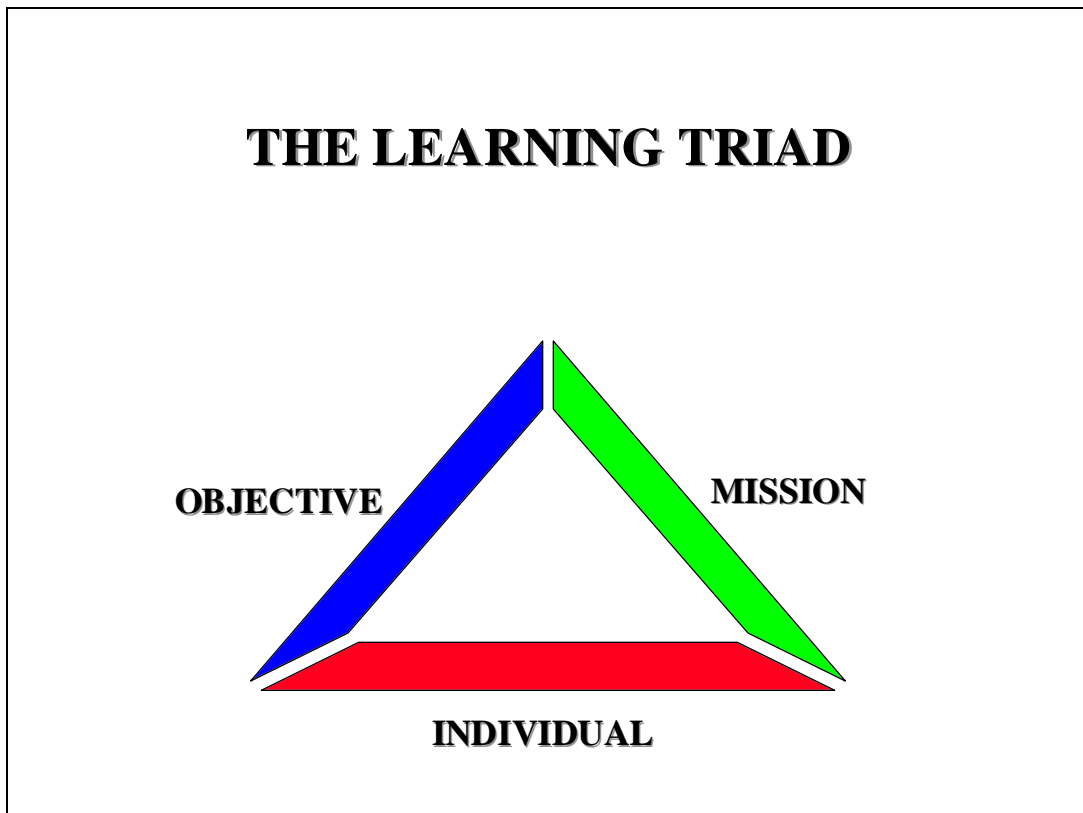
“infrastructure and limitations in user support are the central issues that prevent colleges and universities from reaching stages 3 and 4 in the educational use of information technology.”<sup>2</sup> In fact, they note that colleges and universities often operate at one-half to one-fifth of the support levels normally invested by corporations, suggesting that important support tasks are “probably not being done well or right, or at all.”<sup>3</sup> As noted above, the ASF of 2025 will need the high capacity of the GII and a significant support staff in order for our ALE to succeed. Moreover, while today’s Air Force has embarked on the technology integration process, we must keep our vision in focus over the next several years to ensure we successfully achieve stage 4 across the force by 2025.

Our second suggestion serves as an adjunct to this lengthy implementation process. We must remember the most overlooked of Jack Edwards’ rules for getting started on technology: Solve problems—don’t buy toys.<sup>4</sup> As we proceed to integrate technology to build our adaptive learning environment, we must determine the learning problems we need to overcome and then target the technologies we need to resolve them. We cannot afford to allow “cool” technology to overshadow the more critical goal of educating and training our brilliant warriors. Technology must not be the focus of our integration efforts; people and their ability to learn must remain central.

We believe that these rules present an excellent foundation for integrating technologies that will hold true through 2025. Moreover these suggestions present **three caveats** we must remember in order to smartly integrate technology en route to the ALE.

**The medium isn’t the message.** Obviously, this corresponds closely with the suggestion to solve problems with technology instead of buying toys. Even the most sophisticated technology will not change the fact that the mission of education and

training in 2025 will be much the same as today—to give brilliant warriors the best possible learning opportunities. We want to make them as productive as possible as quickly as possible and then keep them productive throughout their careers. As information systems technology and human factors research mature, we envision the emergence of a content-independent ALE of 2025 which can deliver what *New World Vistas* calls “Precision Guided Training.”<sup>5</sup> In much the same way that precision guided munitions can strike a very specific target, the ALE will be able to specifically tailor learning materials to a particular brilliant warrior’s own individual learning styles, to his/her required learning objectives, and to the unit’s mission goals.<sup>6</sup> These factors constitute the learning triad shown in figure 4.



**Figure 7-1. The Learning Triad**

To develop an ALE which can quickly respond to the dynamic relationships among these three factors, we must capitalize on those technologies which are content independent. Then our education/training technologists can concentrate on content, secure that the appropriate medium will deliver it tailored to a particular learner's need when and where required. Here the medium, the technologies, become transparent and the focus remains on the information and the learner.

**It will not happen quickly.** The process described above emphasizes that successful integration of technology does not happen immediately; it takes place over a matter of years. While money and the state of technology both influence the length of this process, one of the key factors is people. Significant evidence suggests that technology grows much faster than our society and its members can adapt to it. As Shoshana Zuboff of the Harvard Business School notes, "So far patterns of morality, sociality, and feeling are evolving much more slowly than technology."<sup>7</sup> In today's Air Force, we see this phenomenon every day. People express their frustration with a new computer system they don't understand; they vent their anger at incoming E-mail lists which seem to mushroom despite diligent efforts to work through them; they resent having to re-do documents for minor changes simply because it's easy on a computer. In our ongoing quest to integrate technology, we must not forget the people part of the integration equation. As Roger Schank and Chip Cleary, experts in cognitive psychology and educational technology note, "It is easy to install a computer program—changing people and entrenched systems is difficult."<sup>8</sup>

**It will not save money soon.** Green and Gilbert express the crux of this issue very well: "The academic enterprise can do great things with—and will experience significant

benefits from—information technology. But, it won't be cheap, and it will not save money soon.”<sup>9</sup> Initial costs for system hardware, software, connectivity, and support are significant. In the awkward transitional phase, costs increase as organizations have to do business both the old way and the new way. The rapid turnover of technology suggests the need for continued investment in system upgrades. This issue has been a problem for the Air Force in the past; however, we are learning ways to overcome it through better acquisition contracting agreements.

To succeed in our journey to a mature ALE by 2025, we must be willing to make adequate investments in the right technologies to get us there. We must not be deceived into thinking that technology will benefit us most in cost savings. Instead, “what information technology does best—or will do better as it improves—is deliver content and provide access to information and to other people.”<sup>10</sup> By 2025, the ASF may enjoy cost savings as a result of technology; however, its main benefit will be more effective, tailored, and ubiquitous learning opportunities for its brilliant warriors and others who need to learn about ASF issues.

This brings us to our third suggestion. As we build toward the ALE of 2025, we must look beyond simply our ASF. The current trend in the United States military is toward jointness. Congressional mandate, smaller force structures, and new joint structures such as the Joint Requirements Oversight Council and the Joint Warfighting Center are pushing all the services more and more toward joint operations, joint doctrine, and joint weapons systems. Therefore, it stands to reason that we should educate and train our military personnel in the same way that they plan to fight—jointly.<sup>11</sup>

Two areas of jointness particularly lend themselves to joint education and training: joint weapons systems and joint doctrine. In the area of joint, or interoperable, equipment employed across the services, logic and economics suggest the wisdom of joint training on that equipment. The same can be said for both education and training on joint doctrine. The bottom line here is that as we mature in our execution of joint operations, our development of joint doctrine, and our acquisition of joint equipment in the next 30 years, our need for joint education and training will also grow.

In response to this increased need for joint learning, Robert B. Kupiszewski, chief of the Curriculum Affairs Division at the Army Command and General Staff College, has proposed a joint education command comprised “of universities that provide a joint environment for developing doctrine and teaching while offering service-unique curricula.”<sup>12</sup> His proposal involves a three-phase implementation from 1995 to 2015, resulting in a single joint education command dedicated to integrating joint doctrine and educational programs, resources and facilities.<sup>13</sup>

Even if Mr Kupiszewski’s proposal does not come to fruition, a couple of lessons here are clear. First, in an increasingly joint environment, we must develop our ASF ALE to accommodate and enhance joint learning opportunities for both our brilliant warriors and members of other services. Second, people outside today’s Air Force are thinking hard about how to make the changes necessary to adapt our military education and training institutions to take on a greater joint emphasis. The Air Force’s efforts to build the ALE of 2025 could put us in the forefront of this effort. The delivery, development, and tracking systems we envision for the ALE would work equally well to provide joint learning opportunities for members from all services. Moreover, they offer options for

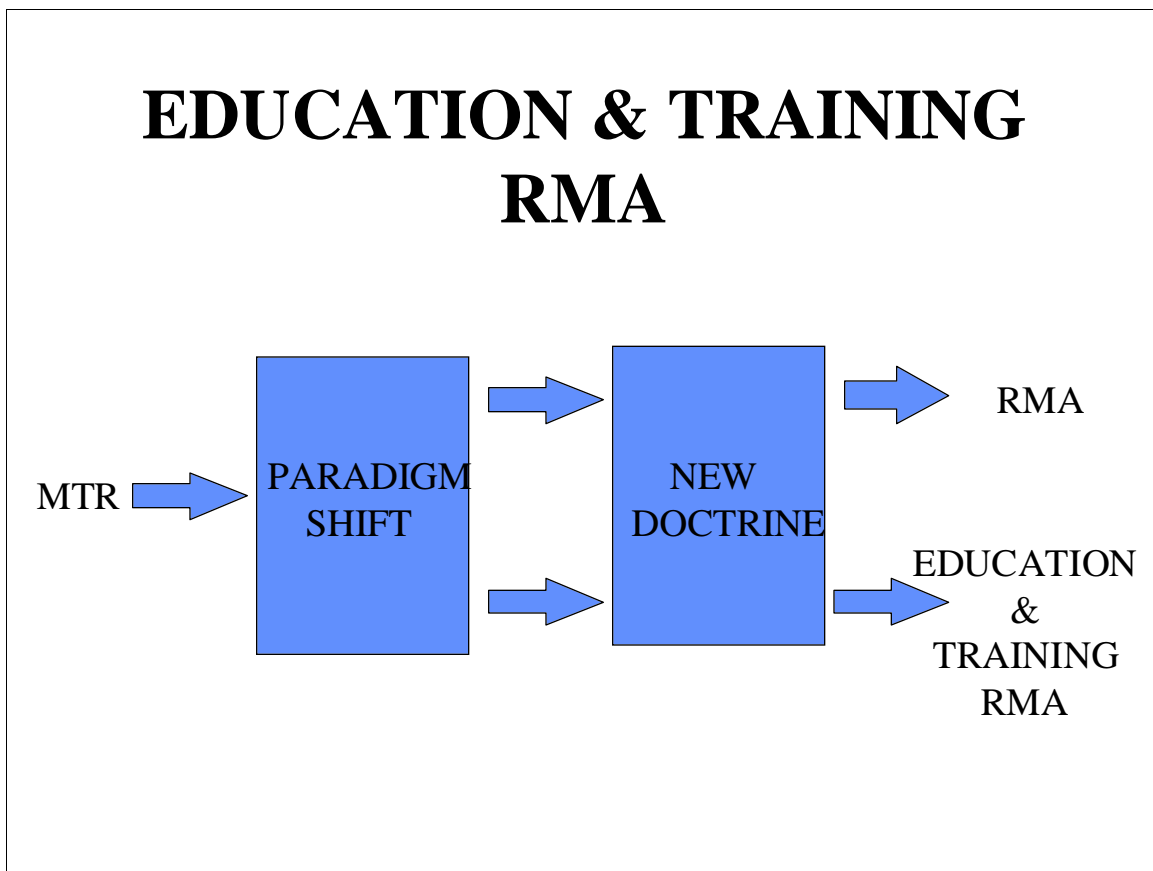
nonmilitary government agencies, private relief agencies, and our allied/coalition partners to learn with us, as well.

Just as our military leaders are increasing their emphasis on joint activities, they are also sharpening their focus on another issue related to information age education and training—the revolution in military affairs (RMA). Adm William Owens recently wrote, “Building the force of the future requires harnessing the revolution in military affairs brought about by technological leaps in surveillance, C<sup>2</sup>, and longer range precision guided munitions.”<sup>14</sup> Our final suggestion concerns this widely discussed information age RMA and its relationship to the ALE of 2025.

In a *Joint Force Quarterly* article titled “Military Education for the New Age,” Lt Gen Ervin J. Rokke (USAF) offers some insights relevant to the integration of information technology into the learning environment. His comments suggest that the prospective RMA currently affecting the conduct of military operations also will impact military education and training. We agree. In fact, the notion of an RMA fits our thesis—that changes to one element of the learning environment creates changes in other elements. We recognize the three requirements for an RMA—technology innovation, new concepts, and changes in the organization<sup>15</sup>--are beginning to converge into what will become the adaptive learning environment of the future. What is revolutionary in this RMA, as in all RMAs, is how we employ or apply our technology and how that application changes the way we view ourselves and what we do. We must attend to all three dimensions of the RMA, not just technology.

With the potential for technologies being almost infinite in 2025, it is the idea-based RMA that captures the imagination of the visionary thinker as opposed to the technology-

focused military technology revolution (MTR). The MTR is happening now. As with each MTR, it brings about operational innovation, new doctrine, and organizational change, which in turn, leads to an RMA (fig 7-2). The mystery, and our key challenge, is to define and pursue new operational concepts and organizational structures which will allow us to harness revolutionary technologies to make something new and better in 2025 instead of the same old thing dressed up to look new.



**Figure 7-2. The Parallel Education and Training RMA**

Lt Gen Rokke concludes his article by referencing changes in professional military education (PME) and the need for a paradigm shift similar to the one we have described in this paper.

There is a current revolution in PME that parallels the RMA. In both cases core functions and procedures are undergoing fundamental changes. In both cases, we are seeing disparate rates of progress among the constituent parts. And in both cases, we are facing difficult resource tradeoffs between traditional approaches on the one hand and information age alternatives on the other. . . . The war colleges must provide the intellectual capital for changing the existing paradigm. The stakes are high in the revolutions in military affairs and professional military education. Significant obstacles and inertia must be overcome. The RMA has the potential to alter priorities among service capabilities. Similarly, the revolution in PME—challenging curricula and teaching methods—has the potential to transform war colleges into innovative centers that spawn and foster new concepts of warfare. In the final analysis, both revolutions demand changes in culture. Since PME shapes and promotes service and joint cultures, it would be difficult if not impossible for the RMA to succeed without a corresponding revolution in war college curricula.<sup>16</sup>

We also forecast a parallel RMA, the education and training RMA. Its result is the adaptive learning environment brought about by innovative application of technologies; new curriculum areas and learning theories; and a fundamental paradigm shift in the way instructors design and deliver instruction and the way students prefer to learn. But we go a step further. We believe that these changes must be managed so that thoughtful integration occurs.

#### Notes

1. Kenneth C. Green and Steven W. Gilbert, “Great Expectations,” *Change*, March-April 1995, 11.
2. *Ibid.*, 14.
3. *Ibid.*
4. Jack L. Edwards, “Getting Started on Technology,” *The Education Digest*, January 1994, 46–47.
5. USAF Scientific Advisory Board, *New World Vistas: Air and Space Power for the 21<sup>st</sup> Century* (unpublished draft, the human systems and biotechnology volume, 15 December 1995), I-1.
6. *Ibid.*, I-10.
7. Shoshana Zuboff, “The Emperor’s New Workplace,” *Scientific American*, September 1995, 162.
8. Roger C. Schank and Chip Cleary, *Engines for Education* (Hillsdale, N.J.: Lawrence Erlbaum Associates, 1995), 72.



9. Green and Gilbert, 18.
10. Ibid., 16.
11. Robert B. Kupiszewski, "Joint Education for the 21st Century," *Joint Force Quarterly*, Spring 1995, 72.
12. Ibid., 73.
13. Ibid., 76.
14. Adm William A. Owens, "JROC: Harnessing the Revolution in Military Affairs," *Joint Force Quarterly*, Summer 1994, 56.
15. Earl H. Tilford, Jr., "The Revolution in Military Affairs: Prospects and Cautions," in Maj Pat Battles et al., eds., *Theater Air Campaign Studies* (Maxwell AFB, Ala.: Air University Press, 1995), 406.
16. Lt Gen Ervin J. Rokke, "Military Education for the New Age," *Joint Force Quarterly*, Autumn 1995, 23.

## **Chapter 8**

### **Conclusion**

The ASF of 2025 will be a far more complex and technical force than the current one. It will be third wave, incorporating new technologies, new operational concepts, new tactics, and new organizational structures. Accordingly, war and conflict in the information age of 2025 will involve far more than pulling a trigger. The changed nature of warfare and the military will increase the value of military education and technical expertise. Smart weapons will require smart soldiers, sailors, marines, and airmen. The military of the future will need warriors who can use their brains, deal with diversity of people and cultures, tolerate ambiguity, take initiative, ask questions, and even question authority.<sup>1</sup> Brilliant warriors entrusted with the defense of our nation will need to be well trained, able to control and work with machines and information systems efficiently, and be mentally and physically superior to the enemy.

To achieve these goals, the ASF will develop an integrated adaptive learning environment to ensure the objectives of education and training are met through the incorporation of advanced information systems technologies such as high capacity global networks, digital knowledge bases, smart software, and virtual reality systems. Moreover, it will nurture more efficient and effective organizations of our academic structures and

processes to instill in our future force the skills, knowledge, and competencies required of brilliant information age warriors.

Education and training in the information age will rely only partly on the application of advanced technologies; the human element will remain the most critical element to successful information technology integration and exploitation. By 2025, we will see the advent of an educational RMA, reflecting the paradigm shift from “providing instruction” to “producing learning.” Included in the RMA will be incorporation of other fundamental changes in the academic culture, curriculum, and teaching methods. The RMA will reflect, as stated by Donald A. Norman, professor emeritus of cognitive science at the University of California, the notion that technology be designed and integrated to conform to the needs of the people it serves.<sup>2</sup>

The integration of technology for education and training is a balancing act. A balance between doing what is “faster” and “cooler” than before and providing what the learner needs in all its forms. At its most complex, integration is an exploration of the point where human psychology, group dynamics, and science intersect. Ideally it forces the integrator to answer the who, what, why, when, and how questions regarding the application of technology to the adaptive learning environment of the future. If successful, technology integration will provide the best education and training possible for ASF personnel, units, and others. It will employ a variety of delivery media to allow learners around-the-world to engage in education and training activities tailored to their individual needs on demand. It will exploit computer technology to create ultrarealistic simulations that enhance training. It will make vast amounts of information available through global networks and digitized libraries to speed and improve critical decision-

making. Ultimately, it will harness the tremendous technical power of the information age to educate and train brilliant warriors who are better prepared to fight and win the conflicts of the future.

#### Notes

1. Alvin and Heidi Toffler, *War and Anti-War* (New York: Warner Books, 1993), 85.
2. Donald A. Norman, "Designing the Future," *Scientific American*, September 1995, 160.

## ***Bibliography***

- AFM 136-2234, *Instructional Systems Development*, 1 November 1993.
- Air Force Modernization Planning, AETC Education Mission Area Plan*. AETC/XORE, 19 July 1995.
- Andrews, Dee Howard, Lynn A. Carrol, and Herbert H. Bell. "The Future of Selective Fidelity in Training Devices." *Educational Technology*, November-December 1995.
- Army Science Board Study. "Distance Learning: The Continuing Evolution of the Digital Army Classroom." Information Technology Laboratory, USAE Waterways Experiment Station, 5 October 1994.
- Antonoff, Michael. "Fake Sets Decorate TV Studios." *Popular Science*, August 1995.
- Barr, Robert B. and John Tagg. "From Teaching to Learning." *Change*, November/December 1995.
- Basic Books, Inc. versus Kinko's Graphic Corp., 758 F Supp 1522 (S.D. N.Y. 1991).
- "Being (Tele)present," *Astronomy* 23, no.8, August 1995.
- Berenson, Paul J. "Revolution in Military Affairs, Some Implications for 21st Century Army." Paper distributed to Air Force 2025, Maxwell AFB, Ala., 12 May 1994.
- Booth, Steven A. "Hot Stuff Eye Candy," *Rolling Stone*, 10 August 1995.
- Bowen, James E. and David G. Bowen. "Virtual Reality Redefines the Organization," *Virtual Reality*, May/June 1995.
- Brauer, Ralph. "The Internet as School, Or Welcome to Our MUD Room." *Technos* 4, no. 3, Fall 1995.
- Berge, Zane L. and Mauri P. Collins, ed. *Computer Mediated Communication and the Online Classroom. Volume II Higher Education*. Cresskill, N.J.: Hampton Press, 1995.
- Boyd, Lt Gen Charles. Briefing to Gen Merrill A. McPeak, Air Force Wargaming Center, Maxwell AFB, Ala., January 1992.
- Bull, G. M., et al. *Information Technology, Issues for Higher Education Management*. Bristol, Pa.: Jessica Kingsley Publishers, 1994.
- Cartwright, G. Phillip. "Distance Learning." *Change*, July-August 1994.
- Chance, Paul. "Master of Mastery." *Psychology Today*, April 1987.

- Chen, I., K., J. Hastings Griffin, and M. Mason. "Called on the Carpet by a Computer." *Health* 4, July 1995.
- Chiou, Guey-Fa. "Beliefs and Computer-Based Learning." *Educational Technology*, May-June 1995.
- Claxton, Charles S., and Patricia H. Murrell. *Learning Styles: Implications for Improving Educational Practices*. ASHR-ERIC Higher Education Report No. 4. Washington, D.C.: Association for the Study of Higher Education, 1987.
- Coffman, Lt Col Alfred M., Jr. "Strategic Environmental Assessment for Modernization Planning." Report of the Strategic Planning Division, Directorate of Plans, Headquarters United States Air Force, 6 June 1994.
- Considine, David M. "Are We There Yet? An Update on the Media Literacy Movement." *Educational Technology*, July-August 1995.
- "Curriculum Analysis and Media Selection Guide." Paper prepared by the Distance Learning Working Group, Air University Headquarters, Maxwell AFB, Ala., 4 February 1994.
- Daviss, Bennett. "Networking the Brain: Tomorrow's Computers in a Lab Dish Today." *Omni*, Fall 1995.
- Dede, Chris. "The Evolution of Constructivist Learning Environments: Immersion in Distributed, Virtual Worlds." *Educational Technology*, September-October 1995.
- Der Derian, James. "Cyber-Deterrence." *Wired*, September 1994.
- Drucker, Peter F. "The Age of Social Transformation." *The Atlantic Monthly* 274, no. 5, November 1994.
- Edwards, Jack L. "Getting Started on Technology." *Education Digest*, January 1994.
- Ehrmann, Stephen C. "Asking the Right Questions." *Change*, March-April 1995.
- Encyclopaedia Britannica Educational Corp. versus Crooks, 558 F Supp 1247 (W.D.N.Y 1983).
- Engelbart, Douglas. "Dreaming of the Future." *Byte*, September 1995.
- Fisher, Arthur. "The End of School." *Popular Science*, January 1994.
- "Force XXI, America's Army in the 21st Century." *Army Focus '94*, September 1994.
- Gates, Bill. *The Road Ahead*. New York: Penguin Books, 1995.
- Gilbert, Steven W. "Teaching, Learning, and Technology." *Change*, March-April 1995.
- . "The Technology Revolution." *Change*, March-April, 1995.
- Goldberg, Bruce and John Richards. "Leveraging Technology for Reform: Changing Schools and Communities into Learning Organizations." *Educational Technology*, September-October 1995.
- Gooler, Dennis D. *The Education Utility, The Power to Revitalize Education and Society*. Englewood Cliffs, N.J.: Educational Technology Publications, 1986.

- Green, Kenneth C. "Paying the Digital Piper." *Change*, March-April 1995.
- Green, Kenneth C. and Steven W. Gilbert. "Great Expectations." *Change*, March-April 1995.
- . "The New Computing in Higher Education." *Change*, May-June 1986.
- Harasim, Linda M. *Online Education Perspectives on a New Environment*. New York: Praeger Publishers, 1990.
- . "Conferencing Issues and Decisions." *Learning Without Boundaries*. New York: Plenum Press, 1994.
- Healey, Brian G., Stacy E. Foran, and David R. Walt. "Photodeposition of Micrometer-Scale Polymer Patterns on Optical Imaging Fibers." *Science*, 25 August 1995.
- Hertzke, Eugene R., and Warren E. Olson. *TQE, Technology, and Teaching*. Thousand Oaks, Calif.: Corwin Press, 1994.
- Institute for National Strategic Studies. *Strategic Assessment 1995: US Security Challenges in Transition*. Washington, D.C.: U.S. Government Printing Office, 1995.
- Intellectual Property and the NII. *Draft Report of the Working Group of Intellectual Property Rights*, July 1994.
- Jonassen, David H., ed. *Instructional Design for Microcomputer Courseware*. Hillsdale, N.J.: Lawrence Erlbaum Associates, 1988.
- . "Supporting Communities of Learners with Technology: A Vision for Integrating Technology with Learning in Schools." *Educational Technology*, July-August 1995.
- Jonassen, David H., and M. E. Davidson. "Learning with Media: Restructuring the Debate" *Educational Technology Research and Development* 42, no. 2, 1993.
- Jones, Marshall G., John D. Farquhar, and Daniel W. Surry. "Using Metacognitive Theories to Design User Interfaces for Computer-Based Learning." *Educational Technology*, July-August 1995.
- Kearsley, Greg, and William Lynch. *Educational Technology Leadership Perspectives*. Englewood Cliffs, N.J.: Educational Technology Publications, 1994.
- Kearsley, Greg, and David Wizer. "The Effectiveness and Impact of Online Learning in Graduate Education." *Educational Technology*, November-December 1995.
- Kelley, Lt Gen Jay W. "Brilliant Warrior." Unpublished paper. Air University Headquarters, Maxwell AFB, Ala., 1996.
- Kenney, Stephen. "Professional Military Education and the Emerging Revolution in Military Affairs." Unpublished paper of the Science Applications International Corporation.
- Kerfoot, Franklin W., and Peter K. Runge. "Future Directions for Undersea Communications." *AT&T Technical Journal*, January-February 1995.
- Kline, John. "Education and Training Today: Some Differences." *Air University Review* 36, no. 2, January-February 1985.

- Knowles, Malcolm S. *The Modern Practice of Adult Education: From Pedagogy to Andragogy*. New York: Cambridge Books, 1980.
- . *Andragogy in Action: Applying Modern Principles of Adult Learning*. San Francisco: Jossey-Bass, 1984.
- Kupiszewski, Robert, B. “Joint Education for the 21st Century.” *Joint Force Quarterly*, Spring 1995.
- Langreth, Robert. “Scoping For Data.” *Popular Science*, August 1995.
- Laszlo, Alexander, and Kathia Castro. “Technology and Values: Interactive Learning Environments for Future Generations.” *Educational Technology*, March-April 1995.
- Lee, William B., and Edward John Kazlauskas. “The Ecole Moderne: Another Perspective on Educational Technology.” *Educational Technology*, March-April 1995.
- Liebnowitz, Jay. “Expert Systems: Dead or Alive?” *Educational Technology*, March-April 1995.
- Lipkin, Richard. “Teeny-weeny Transistors.” *Science News*, 6 May 1995.
- Lomond, Loch. “Micro, Nano, Pico, Femto.” *The Economist*, 14 October 1995.
- Luke, Al. chair, United States Department of Defense Distance Learning Workshop, Report of Special Interest Groups, National Defense University, 23–24 March 1994.
- Marcus versus Rowley, 695 F 2d 1171 (9th Cir. 1983).
- McCluskey, Lawrence. “Gresham’s Law, Technology and Education.” *Phi Delta Kappan*, March 1994.
- McGuinness, Kevin. “Nanoplastics.” *The Futurist*, January-February 1995.
- McMichael, James S. Memorandum to John Kline, Maxwell AFB, Ala. Subject: White Paper, The Acquisition Education and Training Program, 15 October 1993.
- Means, Barbara., ed. *Technology and Education Reform*. San Francisco: Jossey-Bass, 1994.
- Means, Barbara, Kerry Olson, and Ram Singh. “Beyond the Classroom.” *Phi Delta Kappan*, September 1995.
- Merrill, M. David. *Instructional Design Theory*. Englewood Cliffs, N.J.: Educational Technology Publications, 1994.
- Metz, Paul. “The View from a University Library: Revolutionary Change in Scholarly and Scientific Communications.” *Change*, January-February 1995.
- Monahan, Brian D., and Matthew Dharm. “The Internet for Educators: A User’s Guide.” *Educational Technology*, January-February 1995.
- Negroponte, Nicholas P. *Being Digital*. New York: Vintage Books, 1995.
- . “The Digital Revolution: Reasons for Optimism.” *The Futurist*, November-December 1995.



- Nickerson, Raymond S., and Philip P. Zodiates, ed. *Technology in Education: Looking Toward 2020*. Hillsdale, N.J.: Lawrence Erlbaum Associates, 1988.
- Norman, Donald A. "Designing the Future." *Scientific American*, September 1995.
- Office of the Secretary of Defense (Net Assessment). Report of Roundtable Conference on the Revolution in Military Affairs. US Army TRADOC, Fort Monroe, Va., 13–14 December 1995.
- Owens, Adm William A. "JROC: Harnessing the Revolution in Military Affairs." *Joint Force Quarterly*, Summer 1994.
- Pape, William R. "Beyond E-mail," *Inc.* 17, no. 4, Summer 1995.
- Perelman, Lewis J. *School's Out: A Radical New Formula for the Revitalization of America's Educational System*. New York: Avon Books, 1992.
- Peterson, John L. *The Road to 2015: Profiles of the Future*. Madera, Calif.: Waite Group Press, 1994.
- Pope, Gregory T. "Hypersonic Hyperbrain." *Popular Mechanics*, November 1995.
- Port, Otis. "Sifting through Data with a Neural Net." *Business Week*, 30 October 1995.
- Postman, Neil. "Virtual Students, Digital Classroom." *Nation*, 9 October 1995.
- . "Technology as Dazzling Distraction." *Education Digest*, April 1994.
- Pournelle, Jerry. "Of COM Ports and Digital Frogs." *Byte*, September 1995.
- "Professional Military Education (PME) in 2020." *Spacecast 2020*, 1, Air University, Maxwell AFB, Ala., June 1994.
- "Quantum Caverns: A Thousand Points of Light." *AT&T Technical Journal*, January-February 1995.
- Redding, G. A., and J. D. Fletcher. "Technical and Administrative Issues in Distributed Training Technology." *Learning Without Boundaries, Technology to Support Distance/Distributed Learning, Defense Research Series 5*. New York: Plenum Press, 1994.
- Regis, Ed. "It's a Small, Small World." *Reason*, December 1995.
- Robinson, Clarence A., Jr. "Virtual Teleconferencing Spurs Factory, Medical Collaboration" *Signal*, April 1995.
- Rokke, Lt Gen Ervin J. "Military Education for the New Age." *Joint Force Quarterly*, Autumn 1995.
- Salvador, Roberta. "What's New in Virtual Reality?" *Electronic Learning*, May-June 1995.
- Savery, John R., and Thomas M. Duffy. "Problem Based Learning: An Instructional Model and Its Constructivist Framework." *Educational Technology*, September-October 1995.

- Schank, Roger C., and Chip Cleary. *Engines for Education*. Hillsdale, N.J.: Lawrence Erlbaum Associates, 1995.
- Schon, Donald A. "Knowing in Action: The New Scholarship Requires a New Epistemology." *Change*, November-December 1995.
- Seels, Barbara B., and Rita C. Richey. *Instructional Technology: The Definition and Domains of the Field*. Washington, D.C.: Association for Educational Communications and Technology, 1994.
- Seidel, Robert J., and Paul R. Chatelier, ed. *Learning Without Boundaries: Technology to Support Distance/Distributed Learning*. New York: Plenum Press, 1994.
- "Seeing Red on Nintendo." *Popular Science*, March 1995.
- Shapiro, Wendy L., Katherine Roskos, and Phillip G. Cartwright. "Technology-Enhanced Learning Environments." *Change*, November-December 1995.
- Sipress, Jack M. "Undersea Communications Technology." *AT&T Technical Journal*, January/February 1995.
- Smith, Donald A., Paul J. Sticha, and John E. Morrison. "Soldier as Adaptive Problem Solver." Paper presented to Roundtable Conference on Military Training and the Potential Revolution in Military Affairs, Fort Monroe, Va., 13–14 December 1995.
- Southern Association of Colleges and Schools. "Policies, Procedures, and Guidelines of the Commission on Colleges" Decatur, Ga., 1992.
- Sprinthall, Norman A., and Richard C. Sprinthall. *Educational Psychology A Developmental Approach*. New York: McGraw-Hill, 1990.
- Stevens, Jane Ellen. "The Growing Reality of Virtual Reality." *BioScience*, July-August 1995.
- Strategic Environment Assessment for Modernization Planning, Headquarters USAF, DCS Plans and Operations, Directorate of Plans, Strategic Planning Division, 1480 Air Force Pentagon, Washington D.C., 6 June 1994.
- Sullivan, Michael F. "Needed Now: A New Model for Pedagogy" *Technos* 4, no. 3, Fall 1995.
- Swanson, Judy. "Systematic Reform in the Professionalism of Educators." *Phi Delta Kappan*, September 1995.
- Swerdlow, Joel L. "Information Revolution." *National Geographic* 188, no. 4, October 1995.
- Tilford, Earl H. "The Revolution in Military Affairs: Prospects and Cautions." *Theater Air Campaign Studies Course Book*, Air Command and Staff College, AY 1996.
- Toffler, Alvin, and Heidi Toffler. *War and Anti-War*. New York: Warner Books, Inc., 1993.
- Travis, John. "Galaxy Experts Train Electronic Stand-Ins." *Science*, 10 February 1995.
- Van Horn, Royal. "Future-Proof Schools" *Phi Delta Kappan*, September 1995.

- Varian, Hal. "The Information Economy." *Scientific American*, September 1995.
- "Virtual Reality Brings Ancient Worlds to Life." *The Futurist*, May-June 1995.
- "Virtual Reality for Soldiers, Cops." *The Futurist*, November-December 1995.
- "Undersea Cable Upgrades Proven Feasible." *AT&T Technical Journal*, January-February 1995.
- USAF Scientific Advisory Board. *New World Vistas: Air and Space Power for the 21<sup>st</sup> Century*, Summary Volume. Washington, D.C.: USAF Scientific Advisory Board, 15 December 1995.
- . *New World Vistas: Air and Space Power for the 21<sup>st</sup> Century*. Unpublished drafts, the Information Technology Volume and the Human Systems and Biotechnology Volume. 15 December 1995.
- Weinstein, Claire E., Ernest T. Goetz, Patricia A. Alexander, ed. *Learning and Study Strategies, Issues in Assessment, Instruction, and Evaluation*. San Diego: Academic Press, Inc., 1988.
- Willis, Jim. "The Age of Multimedia and Turbonews." *The Futurist*, September-October 1995.
- Wilson, Brent G. "Metaphors for Instruction: Why We Talk About Learning Environments." *Educational Technology*, September-October 1995.
- Wulf, William A. "Warning: Information Technology Will Transform the University." *Issues in Science and Technology*, Summer 1995.
- Zarowin, Stanley. "Thinking Computers." *Journal of Accountancy*, November 1995.
- Zuboff, Shoshana. "The Emperor's New Workplace." *Scientific American*, September 1995.

### Other Sources

- American Association for Higher Education's listserv on technology: AAHESGIT*, on line at LISTPROC@LIST.CREN.NET, in the body of the message, type "SUBSCIB AAHESGIT [yourfirstname yourlastname]".
- Association for the Educational Communications and Technology, Inc., 1025 Vermont Ave., NW, Suite 820, Washington, D.C. 20005.
- Cartwright, G. Phillip. Bureau of Research Training and Services, Kent State University, on line at pcartwri@kentvm.kent.edu.
- Educational Technology Publications, Inc., 700 Palisade Ave., Englewood Cliffs, NJ 07632, (201) 871-4007; Fax (201) 871-4009.
- Flashlight Project* (a three-year effort to develop and share evaluation procedures. Colleges and universities will be able to use these procedures to assess their educational strategies for using technology), Listserv on Internet: listproc@listproc.wsu.edu with one line message "Subscribe f-light yourfirstname yourlastname".

Green, Kenneth C. Professor of Higher Education and Director of Technology, Teaching, and Scholarship Project, USC, *Campus Computing 1994: The USC National Survey of Desktop Computing in Higher Education*, on line [kcgreen@usc.edu](mailto:kcgreen@usc.edu).

Markwood and Johnstone's Study. "New Pathways to a Degree: Technology Opens the College" and "New Pathways to a Degree: Seven Technology Stories," Boulder, Col.: Western Interstate Commission for Higher Education, 1994.